



**Complete your panel
with our panel accessories**



Larsen & Toubro is a technology-driven company that infuses engineering with imagination. The Company offers a wide range of advanced solutions in the field of Engineering, Construction, Electrical & Automation, Machinery and Information Technology.

L&T Switchgear, a part of the Electrical & Automation business, is India's largest manufacturer of low voltage switchgear, with the scale, sophistication and range to meet global benchmarks. With over five decades of experience in this field, the Company today enjoys a leadership position in the Indian market with a growing international presence.

It offers a complete range of products including powergear, controlgear, industrial automation, building electricals & automation, reactive power management, energy meters, and protective relays. These products conform to Indian and International Standards.



INDEX

AC Rotary Switches	1
DC Rotary Switches	31
Load Break Switches	35
Wires & Cables	53
Cable Ducts	59
Timing Devices & Supply Monitors	65
Modular Remote Control Units	127
Analog Panel Meters & CT	149
Digital Panel Meters	159



AC Rotary Switches

Introduction

Cam Operated Rotary Switches used to perform Make and Break operation in a sequential way by rotating the switch to different positions.

The Cam, which closes and opens the contacts, has rotary movement in multiple positions, thereby controls multiple Circuit functions.

Further, the flexibility in the switch type selection covering various current / voltage ratings and options to select the number of contacts, is added advantage. This ensures that a right switch is chosen for the desired application. CAM Switches thus offer complete design flexibility to assemble complex switching programs, contact ratings and customize all switching applications. Cam Switches are suitable for AC as well as DC switching applications.

The basic operating mechanism of Cam Switch is to suit intended application coupled with 'Quick-Make', 'Quick-Make-Quick-Break' and 'Spring Return' operating mechanisms.

The Cam Switches offers versatile mounting options in addition to Standard Panel / Flush Mounting and other special features like single hole, door interlocking, padlock, lock and key for various needs. The wide option such as type of knob, front plate color and customized marking on the marking plate eliminates the need of separate label on the panel.

The superior quality of engineering material and "Double Butt" contacts with silver bimetal on copper/brass provide stable electrical performance. The high-grade engineering plastics with high tracking index like nylon, silicon and glass filled polyamide for the components ensures greater mechanical strength.

Advanced manufacturing processes for Cam Switch components under stringent quality conditions ensures durability, reliability and enhanced life.

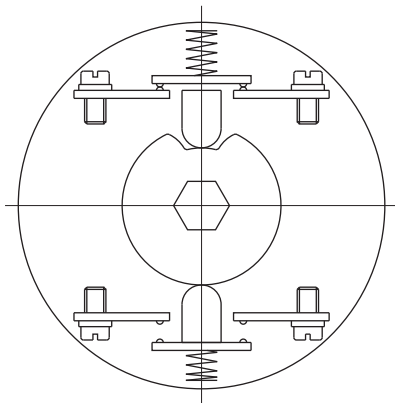

Cam Assembly

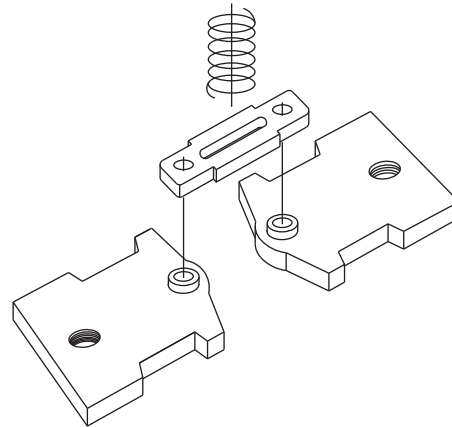

Contact Assembly

Series S, TP, RT and SL Cam Switches incorporate two double break silver alloy contacts per stage at 180 degree disposition. The AC Switches are 'Quick Make-Slow Break' with in-built latching device feature in cam design. The Cam Switches can be offered for DC applications with additional contacts in series according to the DC switching voltage and with suitable duration the DC Switches are 'Quick Make - Quick Break'.

Contacts : Double break type AgCdO
Insulation : Glass filled polyamide with high tracking index

Operating temp : -15°C to 55°C
Operating frequency : 50 to 60 Hz
Humidity : 95%, Rh 48 hours

S Series Open Version



- Available from 6 to 400 A
- Open terminals for easy accessibility

TP Series Touch Proof



- Available from 6 to 20 A
- Finger protection (IP20)

RT Series Touch Proof & Rear Termination



- Available from 16 to 63 A
- Finger protection
- Convenient accessibility

SL Series Touch Proof & Screwless Termination



- Available from 6 & 10 A
- Finger protection (IP20)
- Cage clamp

AC Duty Rating

Category	Typical AC Application
AC-1	Non-Inductive or slightly inductive loads, Resistance furnaces
AC-3	Squirrel-cage motors : starting switching off motors during running
AC-15	Control of AC electromagnetic loads
AC-21-A	Switching of resistive loads, Including moderate overloads (frequent switching)
AC-23-A	Switching of motor loads or other highly inductive loads (frequent switching)

DC Duty Rating

Category	Typical DC Application
DC-1	Non-Inductive or slightly inductive loads, Resistance furnaces
DC-22	Switching of resistive loads, Including Control of DC electromagnets
DC-13	Switching of motor loads or other
DC-23	Highly inductive loads
----	----

IEC/EN Ratings

AC Rating Code	Unit	S6 TP6	S10 TP10	S16/TP16/ RT16	S20/TP20/ RT20	S25 RT25	S32 RT32	S40 RT40	S63 RT53	S80	S100	S125	S200	
Rated Operational Voltage (Ue)	V	440	440	690	690	690	690	690	690	690	690	690	690	
Rated Frequency	Hz	50/60	50/60	50/60	50/60	50/60	50/60	50/60	50/60	50/60	50/60	50/60	50/60	
Rated Impulse with stand Voltage (Uimp)	Kv	4	4	6	6	6	6	6	6	6	6	6	6	
Rated Operational Current (Ie) AC21/AC1	A	6	10	16	20	25	32	40	63	80	100	125	200	
Rated Uninterrupted Current (Ith)	A	8	12	20	25	32	40	50	80	100	125	150	225	
Rated Operational Power														
AC23A "3 Ph, 415 V"	KW	2.2	3	7.5	7.5	11	15	18.5	22	33	41	45	55	
	A	--	--	13	13	19	26	32	38	57	71	78	95	
AC3	KW	1.5	3	5.5	5.5	7.5	11	15	18.5	22	33	37	45	
"3 Ph, 415 V"	A	--	--	10	10	13	19	26	32	38	57	64	78	
Short Circuit Capacity														
Rated Fuse Short Circuit Current	KA	3	3	5	5	10	10	20	20	25	25	25	25	
Fuse Size (Type gG/gM)	A	6	10	16	20	25	32	40	63	80	100	125	200	
Terminal Cross Section														
Single / Multiple	min	mm ²	0.7	0.7	1.5	1.5	1.5	2.5	2.5	4	6	10	10	10
	max	mm ²	1.5	1.5	4	4	4	6	10	16	25	35	50	70
Fine strand	min	mm ²	0.7	0.7	1	1	1	1.5	2.5	2.5	6	10	10	10
	max	mm ²	1.5	1.5	2.5	2.5	2.5	4	6	10	16	25	35	50
Terminal Cross Section	Metric	M3.5	M3.5	M3.5	M3.5	M4	M4	M5	M5	2XM5	2XM5	2XM5	M10	
Terminal Tightening Torque	Nm	0.8	0.8	0.8	0.8	1.2	1.2	2	2	2.5	2.5	2.5	2.5	

Note : Rated Duty: 8 Hours, Installation, Operation and Maintenance Condition: Suitable for Environment A (for Industrial Application). Switch life under standard operating conditions: Mechanical 100,000 operations @ 300 cycles / hour, Electrical 10,000 operations at 100% rated duty for 120 cycles/hour.

CSA/UL Ratings

AC Rating Code	Unit	S6	S10	S16 TP16 RT16	S20 TP 20 RT 20	S25 RT25	S32 RT32	S40	S63	S80	S100	S125	S200
Ampere Rating	A	6	10	15	20	20	30	40	55	80	100	100	175
Operational Voltage	V	460	460	600	600	600	600	600	600	600	600	600	600
HP Rating 1 Phase													
120 V	HP	0.25	0.33	0.33	0.33	1.5	1.5	2	3	-	-	-	-
240 V	HP	0.50	0.75	1	1	3	3	5	7.5	-	-	-	-
3 Phase													
120 V	HP	0.75	1	1.5	1.5	3	3	5	7.5	10	10	10	15
240 V	HP	1	1	3	3	7.5	7.5	10	15	20	20	20	25
480 V	HP	1	2	3	3	10	10	20	30	40	40	40	50
600 V	HP	-	-	5	5	15	15	24	40	50	50	50	50



Conformance to standards :
 European : IEC-60947-1 : 1988
 IEC-60947-3 : 1990
 IEC-60947-5 : 1992
 Canadian : CSA 22.2 No.14-2010
 American : UL 508 (2009)

Note : AC4 rating = AC3 rating / 2, Star Delta rating = 60% of AC3 rating

Isolators - ON/OFF Switches

Isolators are ON-OFF Switches to isolate the power to a particular area of operation. Isolator Switch comes in a wide range from 1 Pole to 12 Poles. Isolators with spring return upto 4 Poles are available to energise circuits. Isolators with pre-close contacts are used for safety circuits and for connecting neutral and earth lines. Isolators are generally rated for AC1/AC21 while for motor applications they need to be rated for AC3/AC23 A duty.

Applications: Switching of main/control and instrumentation circuits motor ON-OFF and other special application circuits.



Connection Diagram

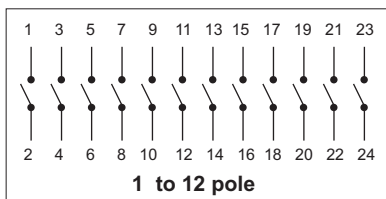

Stayput

Script Plate Marking	60 Degree	90 Degree	90 Degree Complete Rotation	
			Programme Code	No. of Stages
Description	Programme Code	Programme Code	Programme Code	No. of Stages
1 Pole	61001	61191	61195	1
2 Pole	61002	61192	61198	1
3 Pole	61003	61199	61197	2
4 Pole	61004	61194	61196	2
5 Pole	61005	-	-	3
6 Pole	61006	61906	-	3
7 Pole	61007	-	-	4
8 Pole	61008	-	-	4
9 Pole	61009	-	-	5
10 Pole	61010	-	-	5
11 Pole	61011	-	-	6
12 Pole	61011	-	-	6

Feasible Ampere Rating: 6, 10, 16, 25, 32, 40, 63, 80, 100, 125, 200 & 400 Amps

Isolators with Preclose Contact

90 Degree	4 to 5 pole	
Description	Programme code	No. of Stages
4 Pole - 1 Pole Preclose	61194	2
4 Pole - 3 Pole Preclose	61904	2
5 Pole - 3 Pole Preclose	61905	3
3 Pole with Neutral Terminal	61178	2

Feasible Ampere Rating: 6, 10, 16, 25, 32, 40, 63, 80, 100, 125, 200 & 400 Amps

Spring Return Isolators 45 Degree

45 Degree Spring Return to OFF	1 to 4 pole	
Description	Programme code	No. of Stages
1 Pole Spring Return	61351	1
2 Pole Spring Return	61352	1
3 Pole Spring Return	61353	2
4 Pole Spring Return	61354	2

Feasible Ampere Rating: 6, 10, 16, 25, 32, 40 & 63 Amps

Changeover Switches also called Double Throw Switches are available with OFF and without OFF. These are used to operate two different circuits with different number of inputs and outputs. Changeover Switches without Jumpers (potential free contacts) are used to connect two different circuits from two different sources with two different operating voltages or any other incompatible lines. All contacts by default are 'Break Before Make' (BBM) type to avoid overlapping of different circuits. However, for overlapping changeover contacts. 'Make Before Break' (MBB) type are offered against specific requirements.



Application: Power Supply to Generator Changeover, Auto/Manual Changeover, Standby/Remote Changeover and other special application circuits. Mainly used in Distribution Panels, UPS etc.

Connection Diagram

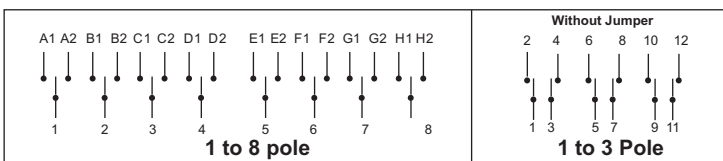

Stayput

60 Degree			90 Degree	
Description	Programme code	No. of Stages	Description	Programme code
1 pole	61025	1	1 pole	61151
2 pole	61026	2	2 pole	61152
3 pole	61027	3	3 pole	61153
4 pole	61028	4	4 pole	61154
5 pole	61029	5	-	-
6 pole	61030	6	-	-
7 pole	61031	7	-	-
8 pole	61032	8	-	-
Feasible Ampere Rating: 6, 10, 16, 25, 32, 40, 63, 80, 100, 125, 200 & 400 Amps				

Spring Return

45 Degree Spring Return to 0			Spring Return from 1 to 0	
Description	Programme code	No. of Stages	Description	Programme code
1 pole	61625	1	1 pole	61364
2 pole	61362	2	2 pole	61365
3 pole	61363	3	3 pole	61369
Feasible Ampere Rating: 6, 10, 16, 25, 32, 40 & 63 Amps				

Without Jumper

60 Degree Stayput without Jumper			45 Degree Spring return without Jumper	
Description	Programme code	No. of Stages	Description	Programme code
1 pole without jumper	62625	1	1 pole without jumper	61761
2 pole without jumper	61626	2	2 pole without jumper	61762
3 pole without jumper	61627	3	-	-
Feasible Ampere Rating: 6, 10, 16, 25, 32, 40, 63, 80, 100, 125, 200 & 400 Amps			Feasible Ampere Rating: 6, 10, 16, 25, 32, 40 & 63 Amps	

Connection Diagram

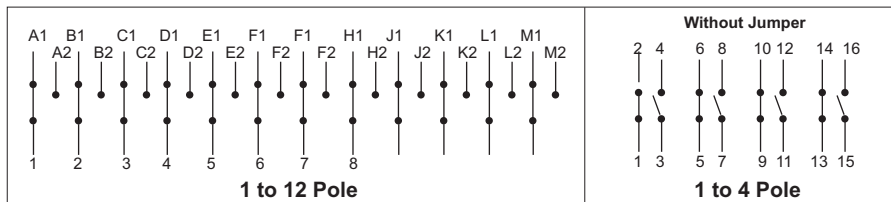

Stayput

90 Degree Complete Rotation			60 Degree		
Description	Programme code	No. of Stages	Description	Programme code	No. of Stages
1 pole	61037	1	5 pole	61041	5
2 pole	61038	2	6 pole	61042	6
3 pole	61039	3	7 pole	61043	7
4 pole	61040	4	8 pole	61044	8
-	-	-	9 pole	61045	9
-	-	-	10 pole	61046	10
-	-	-	11 pole	61047	11
-	-	-	12 pole	61048	12
Feasible Ampere Rating Applicable: 6, 10, 16, 25, 32, 40, 63, 80, 100, 125, 200 & 400 Amps					

Spring Return

45 Degree Spring Return		
Description	Programme code	No. of Stages
1 pole	61371	1
2 pole	61372	2
3 pole	61373	3
Feasible Ampere Rating: 6, 10, 16, 25, 32, 40 & 63 Amps		

Without Jumper

90 Degree Stayput without Jumper			45 Degree Spring return without Jumper		
Description	Programme code	No. of Stages	Description	Programme code	No. of Stages
1 pole without jumper	61637	1	1 pole without jumper	61771	
2 pole without jumper	61638	2	-	-	
3 pole without jumper	61639	3	-	-	
4 pole without jumper	61640	4	-	-	
Feasible Ampere Rating: 6, 10, 16, 25, 32, 40, 63, 80, 100, 125, 200 & 400 Amps			Feasible Ampere Rating: 6, 10, 16, 25, 40 & 63 Amps		

Multistep (Pole-Way) Switches with OFF

These switches are also called as Pole-Way switches, they are available with OFF & without OFF. Multistep does the function of connecting different circuits to a common supply or vice versa. 1 pole, 2 pole & 3 pole are popular for 1 Ph, 2 Ph & 3 Ph supply.











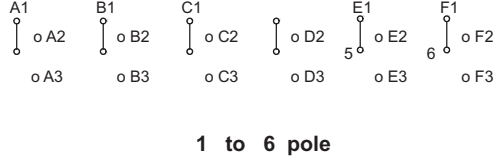

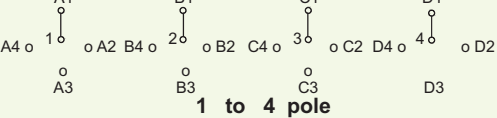

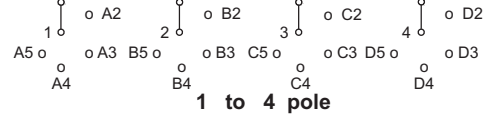

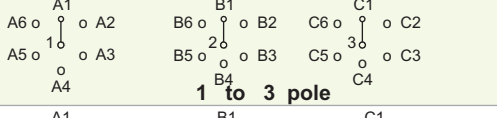
Application : Typical usage tap changing switch for Transformer / Stabilizer and other special application circuits.

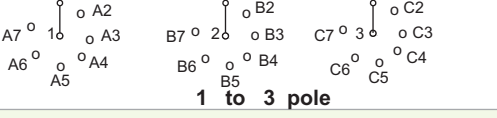

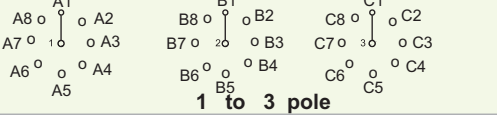

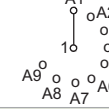

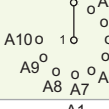
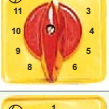
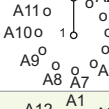
Prog No.	Description	Script Plate Marking	Connecting Diagram / Terminal Marking	No. of Stages		
61059	1 Pole-2 Way			1		
61079	2 Pole-2 Way	2 Way -60°		2		
61099	3 Pole-2 Way			3		
61130	4 Pole-2 Way			4		
61060	1 Pole-3 Way			3 Way -90°		2
61080	2 Pole-3 Way	3				
61100	3 Pole-3 Way	5				
61131	4 Pole-3 Way	6				
61061	1 Pole-4 Way	4 Way -60°				2
61081	2 Pole-4 Way					4
61101	3 Pole-4 Way			6		
61132	4 Pole-4 Way			8		
61062	1 Pole-5 Way	5 Way -60°		3		
61082	2 Pole-5 Way			5		
61102	3 Pole-5 Way			8		
61063	1 Pole-6 Way	6 Way -45°		3		
61083	2 Pole-6 Way			6		
61103	3 Pole-6 Way			9		
61064	1 Pole-7 Way	7 Way -45°		4		
61084	2 Pole-7 Way			7		
61065	1 Pole-8 Way			4		
61066	1 Pole-9 Way			5		
61067	1 Pole-10 Way			5		
61068	1 Pole-11 Way			6		

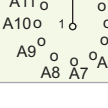
Feasible ampere ratings: 6, 10, 16, 25, 32, 40, 63, 80, 100, 125 & 200 Amps

Multistep (Pole-Way) Switches without OFF

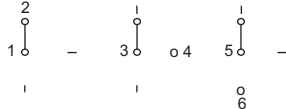
Prog No.	Description	Script Plate Marking	Connecting Diagram / Terminal Marking	No. of Stages
61049	1 Pole-3 Way	 3 Way -60°	 1 to 6 pole	2
61069	2 Pole-3 Way			3
61089	3 Pole-3 Way			5
61120	4 Pole-3 Way			6
61124	5 Pole-3 Way			8
61126	6 Pole-3 Way			9
61050	1 Pole-4 Way	 4 Way -90°	 1 to 4 pole	2
61070	2 Pole-4 Way			4
61090	3 Pole-4 Way			6
61121	4 Pole-4 Way			8
61051	1 Pole-5 Way	 5 Way -60°	 1 to 4 pole	3
61071	2 Pole-5 Way			5
61091	3 Pole-5 Way			8
61122	4 Pole-5 Way			10
61052	1 Pole-6 Way	 6 Way -60°	 1 to 3 pole	3
61072	2 Pole-6 Way			6
61092	3 Pole-6 Way			9
61053	1 Pole-7 Way	 7 Way -45°	 1 to 3 pole	4
61073	2 Pole-7 Way			7
61093	3 Pole-7 Way			11
61054	1 Pole-8 Way	 8 Way -45°	 1 to 3 pole	4
61074	2 Pole-8 Way			8
61094	3 Pole-8 Way			12
61055	1 Pole-9 Way	 9 Way -30°		5
61056	1 Pole-10 Way	 10 Way -30°		5
61057	1 Pole-11 Way	 11 Way -30°		6
61058	1 Pole-12 Way	 12 Way -30°		6

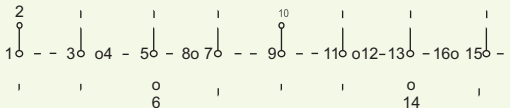
Multistep Switches Without Jumper

61649	1 Pole-3 Way without OFF without Jumper	 3 Way -60°		2
61650	1 Pole-4 Way without OFF without Jumper	 4 Way -90°		2
61670	2 Pole-4 Way without OFF without Jumper		 1 to 2 pole	4

Feasible Ampere Ratings: 6, 10, 16, 25, 32, 40, 63, 80, 100, 125 & 200 Amps

With the help of these switches we can:

- Measure Currents in different circuit switch Current Transformer, a single Ammeter & a switch
- Measure Voltages between Phases and Phase & Neutral with one voltmeter & a switch
- Measure Voltages & Currents of a circuit with one Voltmeter, one Ammeter and a single switch



Voltmeter Selector Switches

Prog No.	Description	Script Plate Marking	Connecting Diagram / Terminal Marking	No. of Stages
61312	3 ph Line to Line			2
61313	3 ph Line to Line & Line to Neutral			3
61314	3 ph Line to Line Line to Neutral & without OFF			3
61317	3 ph Line to Line & L1 to N			3
61318	3 ph Line to Line 2 Sources			4
61311	3 ph Line to Neutral			2
61319	3 ph Line to Line without OFF			2

Feasible Ampere Rating: 6, 10, 16, 25 & 32 Amps

Voltmeter & Ammeter Selector Switches

Prog No.	Description	Script Plate Marking	Connecting Diagram / Terminal Marking	No. of Stages
61336	3 Voltages Line - Line & 3 Currents			5
61337	4 Voltages & 3 Currents			6
61338	3 Voltages Line to Neutral & 3 Currents			5

Feasible Ampere Ratings: 6, 10, 16, 25 & 32 Amps

Ammeter Selector Switches

Prog No.	Description	Script Plate Marking	Connecting Diagram / Terminal Marking	No. of Stages
61325	1 Pole-3 Transformer with OFF			3
61321	1 Pole-1 Transformer			1
61331	1 Pole-2 Transformer			2
61384	1 Pole-3 Transformer without OFF			3
61326	1 Pole-4 Transformer with OFF			4
61327	2 Pole-2 Transformer with OFF			3
61328	2 Pole-3 Transformer with OFF			5
61329	2 Pole-3 Transformer without OFF			5
61330	2 Pole-4 Transformer without OFF			6
71000	Direct Ammeter Selector without Current Transformer			5

Power Factor Meter Switches

73078	One Current Transformer One Voltage Transformer			2
	Two Current Transformer			2

Wattmeter Switch

73071	Two watt meter Method			5
-------	-----------------------	--	--	---

Feasible Ampere Rating: 10 & 16 Amps

These switches directly operate the motor with AC3 or AC4 Duty Rating. They are mainly used for motor Forward - Reversing, Star-Delta, two speed Forward - Reversing and other special switches designed to operate with contactor with built-in tripping feature in the event of power failure and overload.

Motor Reversing Switches

Prog No.	Description	Script Plate Marking	Connecting Diagram / Terminal Marking	No. of Stages
61210	2 Pole			2
61211	3 Pole			3
61253	3 Pole Spring Return	Spring Return to "0"		3

Motor Switches / Star-Delta Switches

Prog No.	Description	Script Plate Marking	Connecting Diagram / Terminal Marking	No. of Stages
61200	OFF-STAR-DELTA			4
61201	Spring Return from STAR to OFF			4
61203	Standard			5
61239	Star Delta with Sequence Locking & LMD Contacts			3
61240	For use with Contactors			4

Feasible Ampere Rating: 6, 10, 16, 25, 32, 40 & 63 Amps

Motor Switches / Multi Speed Switches

Prog No.	Description	Script Plate Marking	Connecting Diagram / Terminal Marking	No. of Stages
61212	2 Speed in one direction Single Winding			4
61213	2 Speed with Center OFF Single Winding			4
61215	2 Speed Single Winding for use with Contactors			5
61217	2 Speed Single Winding Forwarding/Reversing			6
61219	2 Speed 2 Separate Windings			3
61226	3 Speed 2 Windings (O-A-B-A)			6
61243	3 Speed 2 Windings (O-A-B-B)			6

Feasible Ampere Rating: 6, 10, 16, 25, 32, 40 & 63 Amps





Motor Switches - Start & Run Switches

Prog No.	Description	Script Plate Marking	Connecting Diagram / Terminal Marking	No. of Stages
61208	Split-phase Start	Spring return from start to "0" 		2
61209	Split-phase Start Reversing	Spring return from start 		3
61270	Split-phase Start Reversing Switching			3

Feasible Ampere Rating: 6, 10 & 16 Amps

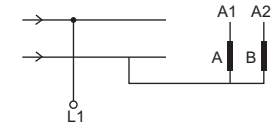
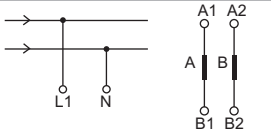
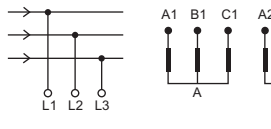
These switches are called Gang Switches, as they increase the capacity of circuits by ganging. They are used for Serialing or Paralleling to derive different circuit capacity. The power of Battery supply can be increased by serialing . The power of resistor can be increased by Paralleling.

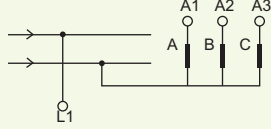
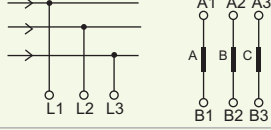
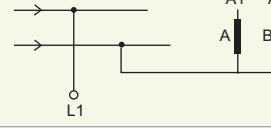
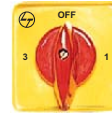
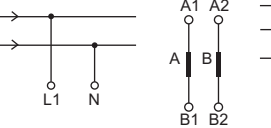
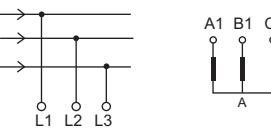
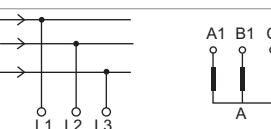

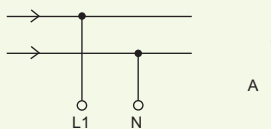

Applications: In Railway coaches for controlling the Battery supply, in Dept of Telecommunication panels and special application circuits.

Prog No.	Description	Script Plate Marking	Connecting Diagram / Terminal Marking	No. of Stages
61109	2 Gang with OFF 1 Pole	 <p>2 Gang 60°</p>	 <p>1 Pole</p>	1
61117	2 Gang with OFF 2 Pole		 <p>2 Pole</p>	2
61111	2 Gang with OFF 3 Pole		 <p>3 Pole</p>	3
61110	3 Gang with OFF 1 Pole	 <p>3 Gang 90°</p>	 <p>1 Pole</p>	2
61118	3 Gang with OFF 2 Pole		 <p>3 Pole</p>	3
61112	3 Gang with OFF 3 Pole		 <p>1 Pole</p>	5
61113	2 Gang, Series with OFF 1 Pole	 <p>2 Gang Series 90°</p>	 <p>2 Pole</p>	1
61115	2 Gang, Series with OFF 2 Pole		 <p>3 Pole</p>	2
61114	2 Gang, Series with OFF 3 Pole		 <p>3 Pole</p>	3
61116	2 Gang Series-Parallel with OFF 2 Pole	 <p>2 Gang Series Parallel 90°</p>	 <p>3 Pole</p>	2

Feasible Ampere Rating: 6, 10, 16, 25, 32, 40 & 63 Amps

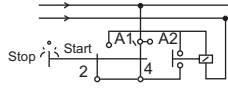
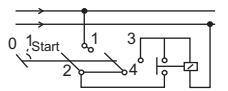
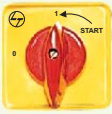
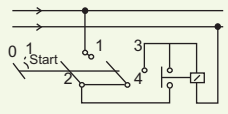
Control Switches are used to energize contactors for controlling motor operations. Most of the Switches are 'Spring Return' type for latching of the circuit with NO contact and facilitate tripping by the tripping device.

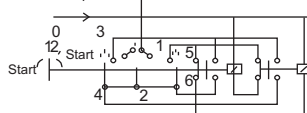
Applications: Control Switches offer unique alternative to multiple "Push Button Stations", when one Switch controls instead of many Push Buttons. Control Switch with many positions are offered for a suitable combination.

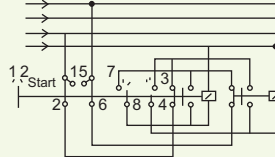
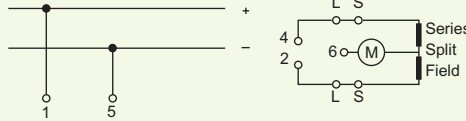
Prog No.	Description	Script Plate Marking	Connecting Diagram/ Terminal Marking	No. of Stages
61300	1 Pole STOP-START with Spring Return	 spring return		1
61388	2 Pole STOP-START with Spring Return			2
61301	1 Pole STOP-START with Spring Return from START to RUN	 spring return from start to "1"		1
61701	Without Jumper			
61307	STOP-START Switch with Spring Return to run for 2 units	 spring return from start		2
61707	Without Jumper			
61366	Contactor Control with Spring Return to OFF	 spring return to "0"		2
61271	Motor Voltage Control Switch			2
Feasible Ampere Rating: 6, 10, 16, 25, 32, 40 & 63 Amps				

Mounting Code	Description	Feasibility					
		6/10A	16/20A	25/32A	40/63A	80/100/125A	200/400A
B03	Front Mounting, Standard Mounting plate		✓	✓	✓	✓	✓
B13	Front Mounting with next size plate	✓	✓	✓	✓	✓	✓
B00	Front Mounting 48x48 plate for 25/32 A and 64x64 plate for 40/63 A			✓	✓		
B19	Single Hole Mounting 32x32 plate for 6/10 A only 48x48 Plate for 16-32 A	✓	✓	✓			
B14	Single Hole Mounting 48x48 plate for 6/10 A	✓					
B33	Front Mounting with Round Padlock for 2 Position (for Isolators)		✓	✓	✓	✓	✓
B30	Front Mounting with Rectangular Padlock 2 Position (for Isolators)		✓	✓	✓	✓	✓
B63	Key Lockable type (Handle/Knob)		✓	✓	✓		
B90	Center Key Lock (Pistol grip Handle in black color only)		✓	✓			
B02	Rear/(Back/Base) Mounting	✓	✓	✓	✓	✓	✓
B21	DIN Rail Mounting on 35 mm Rail 6-32 Amps	✓	✓	✓			✓
B32	Rear/Base Mounting, Door Interlock + Rectangular Padlock (B30+B42)		✓	✓	✓	✓	✓
B34	Rear/Base Mounting, Door Interlock + Round Padlock (B33+B42)		✓	✓	✓	✓	✓
B41	Rear Mounting with Clutch Mechanism on Door (Door Open in all position without Interlock)		✓	✓	✓	✓	✓
B42	Rear Mounting with Interlock Mechanism on Door						
F47	Door Clutch, Mounting Plate at front						
B17	ABS Enclosure	Max stages	upto 4	upto 3	upto 5	upto 5	
B31	ABS Enclosure with Round Padlock (B33+B17)	Max stages		upto 2	upto 2	upto 2	
M17	Metal Enclosure	Max stages	upto 4	upto 4	upto 3		✓
A17	Aluminium Enclosure	Max stages	upto 4	upto 3	upto 2		
B40	Single Hole Mounting with Padlock 48x48 Plate For 16-32 A		✓	✓			
B43	Single Hole Mounting with Center key 48x48 Plate for 16-32 A		✓	✓			
B45	Single Hole Mounting with Round Ring with Knob 16 A-32 A		✓	✓			

B03



IP55 protection from front

Features:

- Standard 4 Hole front panel mounting
- Knob / Handle operable
- Suitable for all switching angles and Spring Return Switches
- Front assembly in 4 different Colors, Yellow / Red, Grey / Black, Black / Black and aluminium finish

Front Mounting

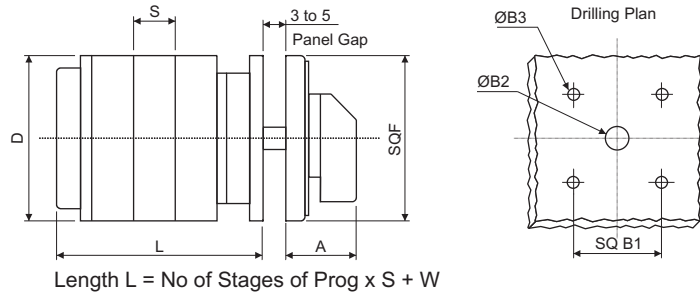

Length L = No of Stages of Prog x S + W

6/10 Amps by default B13 mounting 48 x 48 mm only

Quote B13 for next bigger size front plate

Type	A	B1	B2	B3	D	F	S	W	Max
S6/S10/TP6/TP10/SL6/SL10 (48x48 mm) - B13	28	36	12	4.5	38	48	9.5	18.5	12
S16/TP16/RT16/TP20/RT20	28	36	12	4.5	58	48	12	26	21
S25/S32/RT25/RT32	35	48	12	5.5	64	64	15	27	18
S40/S63/RT40/RT63	44	68	15	5.5	95	88	21	33	12
S80/S100/S125	44	68	15	5.5	118	88	26	40	10
S200	44	68	15	5.5	99	88	32	40	10
S400	44	68	15	5.5	99	88	64	40	4

B19/B14



IP65 protection from front

Features:

- Single hole mounting with std dia 22.5 mm
- Eliminates the need for screws / hardware for Quick-Fit single hole panel fixing
- Easy termination
- Available upto 32 A

Single Hole Mounting (22.5 mm cutout)

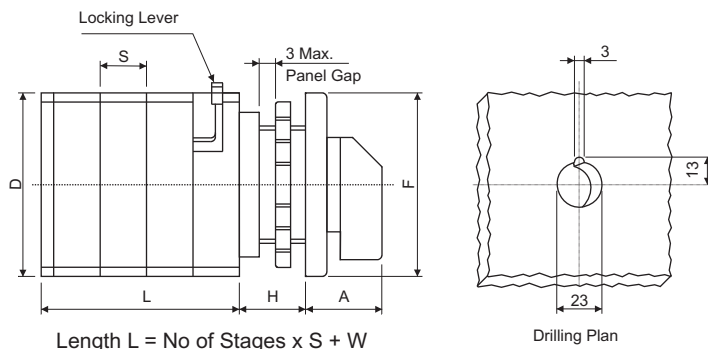

Length L = No of Stages x S + W

Quote B14 for next bigger size front plate (available for 6/10 Amps. only)

Type	Code	A	D	F	S	H	W	Max
S6/S10/TP6/TP10	B19	25	38	32	9.5	13.5	28.5	10
	B14	27	38	48	9.5	13.5	28.5	10
S16/TP16/RT16/TP20/RT20	B19	32	58	48	12	13	36	8
S25/S32/RT25/RT32	B19	32	64	48	15	13	37	6

All dimensions in mm.

B33



IP55 protection from front

Features:

- Four hole round padlockable mounting
- Secure with max. 3 padlocks in OFF position prevents switching ON by unauthorized personnel
- Suitable for switches only with 90° switching angle

Pad Lockable Mounting

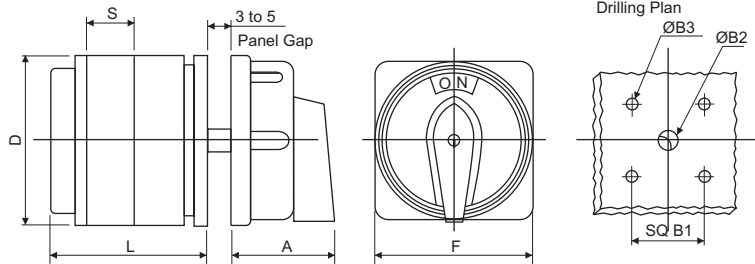

Length L = No of Stages x S + W

F-48 mm with B1-36 mm also available on request for 16, 25, 32 Amps

Type	A	B1	B2	B3	D	F	S	W	Max
S16/TP16/RT16/TP20/RT20	44	36	12	4.5	58	65	12	26	6
S25/S32/RT25/RT32	44	36	12	4.5	64	65	15	27	6
S40/S63/RT40/RT63	48	68	15	5.5	95	95	21	33	6
S80/S100/S125	48	68	15	5.5	118	95	26	40	6
S200	48	68	15	5.5	99	95	32	40	6
S400	48	68	15	5.5	99	95	64	40	3

B30



IP55 protection from front

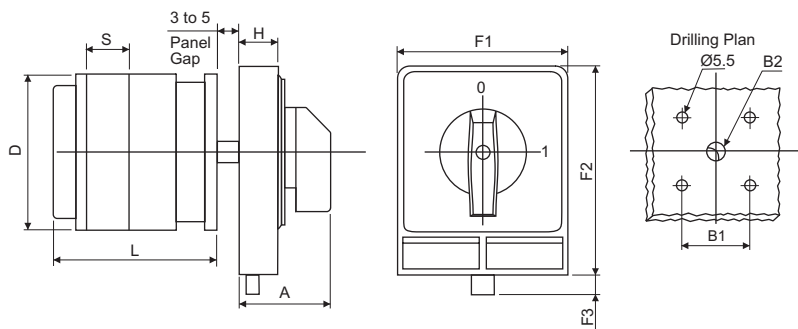

Length L = No of Stages x S + W

Type	A	B1	B2	D	F1	F2	F3	H	S	W	Max
S16/TP16/RT16/TP20/RT20	35	48	12	58	76	104	12	23	12	26	6
S25/S32/RT25/RT32	35	48	12	64	76	104	12	23	15	27	6
S40/S63/RT40/RT63	44	68	15	95	99	128	15	25	21	33	6
S80/S100/S125	44	68	15	118	99	128	15	25	26	40	6
S200	44	68	15	99	99	128	15	25	32	40	6
S400	44	68	15	99	99	128	15	25	64	40	3

All dimensions in mm.

B63



IP40 protection from front

Features:

- Knob / Handle operatable Switch with key lockable assembly prevents switching by unauthorized personnel
- Key lock / Key removable only in OFF position by default, key

Key Lockable

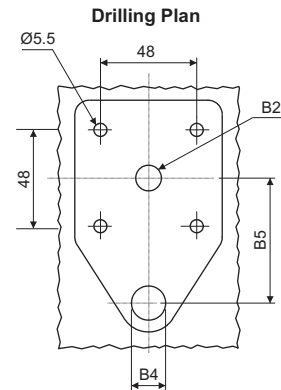
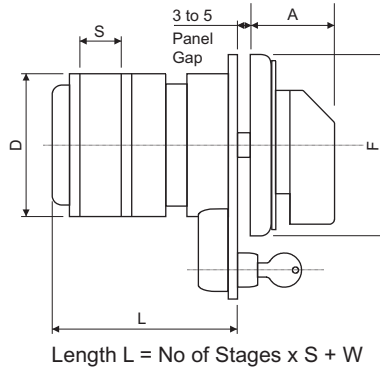

Type	A	B2	B4	B5	D	F	S	W	Max
S16/TP16/RT16/TP20/RT20	35	13	23	43.5	58	64	12	45	21
S25/S32/RT25/RT32	35	13	23	43.5	64	64	15	45	15
S40/S63/RT40/RT63	44	13	23	43.5	95	64	21	47	10

- lockable and removable in any other position to be specified
- Lock assembly can also be provided on any side
- Common key for all Switches

B17



IP55

Features:

- Switch mounted in ABS enclosure
- Provides protection from dust and hazardous material with regular Front Plate and Knob
- Suitable for all switching angles
- Knob / Handle operable
- IP65 can be given on request

Quote B31 (B17 Enclosure and B33 Round Padlock) only for Isolator ON/OFF Switches

Enclosure

LR/HR Model

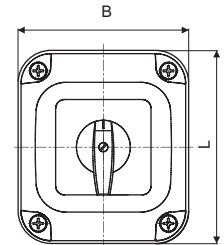
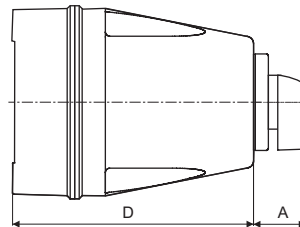
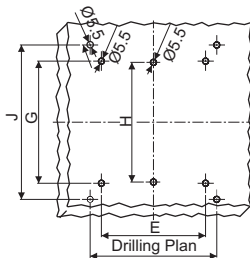

SM, M

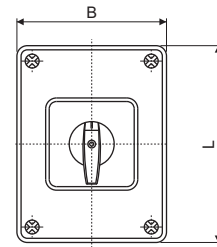
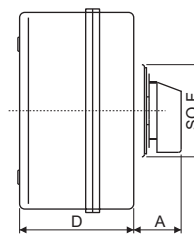
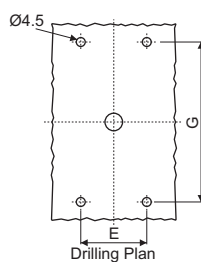

Type	Box Type	A	L	B	D	E	G	Stages
S6/S10/TP6/TP10	SM	28	125	100	72	80	115	4
S16/TP16/RT16	SM	28	125	100	72	80	115	3
S16/TP16/RT16	M	28	175	125	90	105	155	4
S25/S32/RT25/RT32	SM	35	125	100	72	80	115	2
S25/S32/RT25/RT32	M	35	175	125	90	105	155	4
S40/S63/RT40/RT63	M	44	175	125	90	105	155	2

Type	Code	A	L	B	D	E	G	H	I	J	Stages
S25/S32/RT25/RT32	LR	38	130	115	161	87	102	100	-	-	5
S40/S63/RT40/RT63	HR	46	180	155	220	120	100	-	122	147	5

All dimensions in mm.

M17



Metal Enclosure

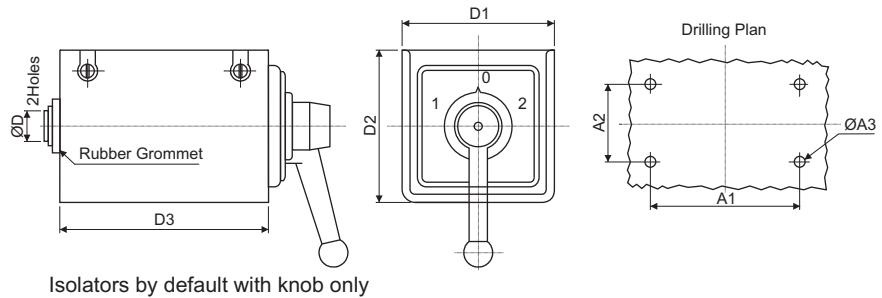

Features:

- Switches mounted in sheet metal enclosures provide protection from hazardous environment
- Knob / Handle operatable
- Suitable for Switches upto 32 A

Type	A1	A2	A3	D1	D2	D3	Max
S6/S10/TP6/TP10	70	60	6	85	89	98	4
S16/TP16/RT16/TP20/RT20	70	60	6	85	89	98	4
S25/S32/RT25/RT32	70	60	6	85	89	98	4
16A Forward/OFF/Reverse Only	70	60	5	75	75	110	-

B02



Rear Mounting

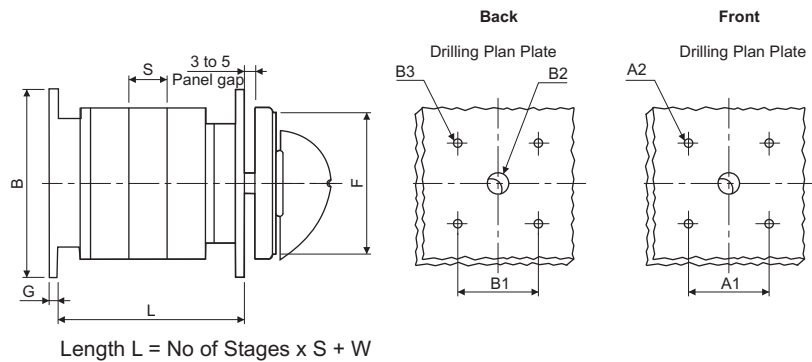

Features:

- Four hole base mounted on rear side of the panel
- Knob / Handle operable
- Can also be used for panel / door mounting

Type	A	A1	B1	B2	B3	F	B	G	S	W	Max
S6/S10/TP6/TP10	28	36	36	9	4.5	48	48	4.5	9.5	26	12
S16/TP16/RT16/TP20/RT20	28	36	48	12	4.5	48	64	3.5	12	30	12
S25/S32/RT25/RT32	35	48	48	12	4.5	64	64	3.5	15	31	8
S40/S63/RT40/RT63	43	68	68	15	5.5	88	88	5	21	41	6
S80/S100/S125	43	68	100	15	5.5	88	124	5	26	48	6
S200	43	68	83	15	5.5	88	104	5	32	48	6
S400	43	68	83	15	5.5	88	104	8	64	48	3

All dimensions in mm.

B21

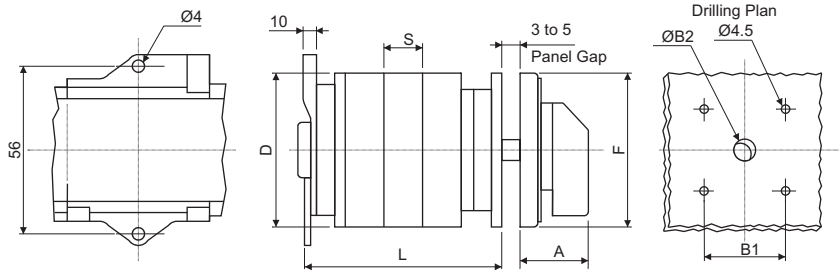

Length L = No of Stages x S + W

Features:

- Snap mounting base on DIN EN50022 (Omega) Rail 35 mm and 1.2 mm thick or two hole rear mounting
- Provides easy termination
- Can also be used for panel / door mounting

Type	A	B1	B2	D	F	S	W	Max
S6/S10/TP6/TP10	28	36	9	38	48	9.5	28.5	10
S16/TP16/RT16/TP20/RT20	28	36	12	58	48	12	37	12
S25/S32/RT25/RT32	35	48	12	64	64	15	38	8

B42

Door Interlock

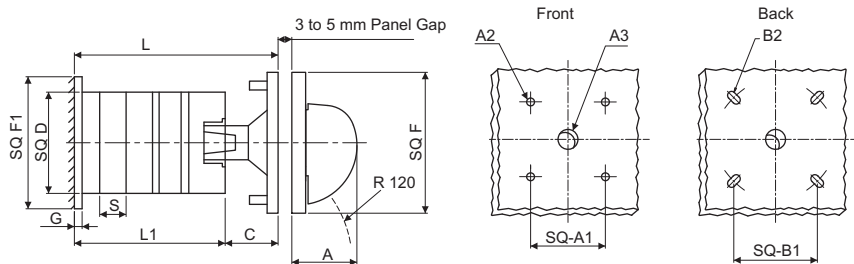

Length L = No of Stages x S + W
L = L1 + C

IP55 protection from front

Features:

- Mounted on rear side of the panel and operated from the front door
- Door inter / lockable mechanism and panel door opens only in OFF position
- Provides safety feature
- Knob / Handle operable

Quote B41 for door to be opened in both positions without door interlock

Type	A	A1	A2	A3	B1	F	B	G	C	N	S	W	Max
S16/TP16/RT16 TP20/RT20	35	48	4.5	15	48	64	64	3.5	25	22	12	54	8
S25/S32/RT25/RT32	35	48	4.5	15	48	64	64	3.5	25	22	15	57	8
S40/S63/RT40/RT63	44	68	5.5	18	83	88	104	5	27	26	21	66	6
S80/S100/S125	44	68	5.5	18	100	88	124	5	27	26	26	72	6
S200	44	68	5.5	18	83	88	104	5	27	26	32	72	6
S400	44	68	5.5	18	83	88	104	8	27	26	64	72	3

All dimensions in mm.

B03

Standard Mounting-Spring Return

(Square Latching Mechanism)



IP55 protection from front

Features:

- Standard 4 hole front panel mounting pistol grip handle operable
- Suitable for 45° / 60° only
- Advanced special star/spring design on latching provides guaranteed spring return operation

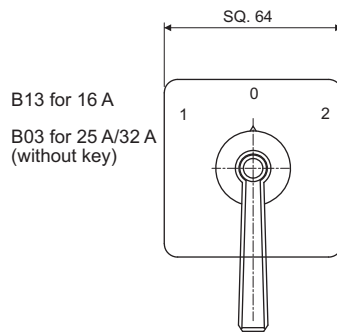
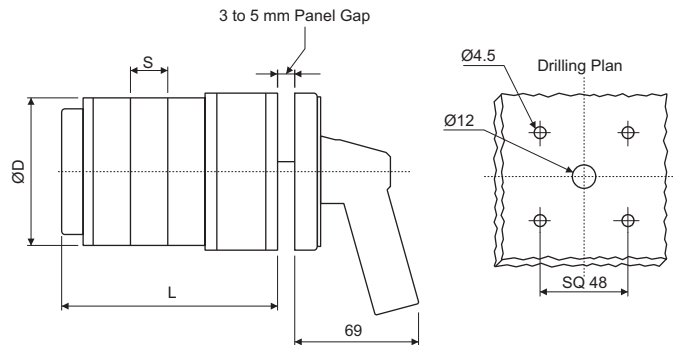

B13 for 16 A
B03 for 25 A/32 A
(without key)

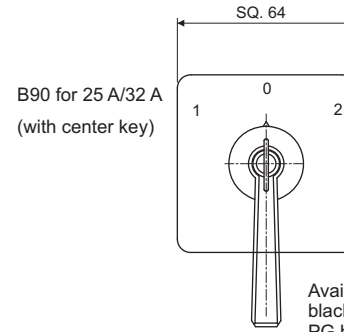

B90 for 25 A/32 A
(with center key)

Available in
black plate/black
PG handle

For B03 without key & for B90 with center key

Type	L (No. of Stages)						
	1	2	3	4	5	6	7
S16/TP16/RT16 (B13)	52.5	64.5	76.5	88.5	100.5	112.5	124.5
S25/S32/RT25/RT32	55.5	70.5	85.5	100.5	115.5	130.5	145.5

All dimensions in mm.

Knobs / Handle Colours ■ RED ■ BLACK

TD - Tear Drop

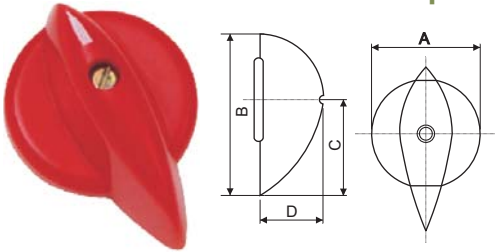

Code - TD	A	B	C	D
S6/S10/TP6/TP10	27	41	25	21
S16/TP16/RT16	27	41	25	21
S25/S32/RT25/RT32	36	51	31	25
S25/S32/RT25/RT32	50	70	42	33

FL - Flag Knob

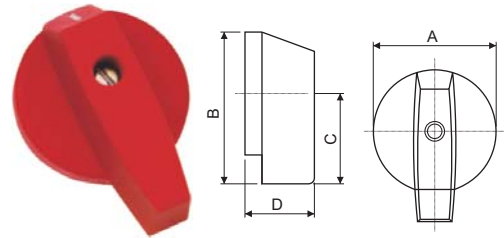

Code - FL	A	B	C	D
S6/S10/TP6/TP10	17	23	13.75	19
S16/TP16/RT16	27	38	24	23
S25/S32/RT25/RT32	27	38	24	23
S25/S32/RT25/RT32	50	68	42.5	32

PG - Pistol Grip Handle

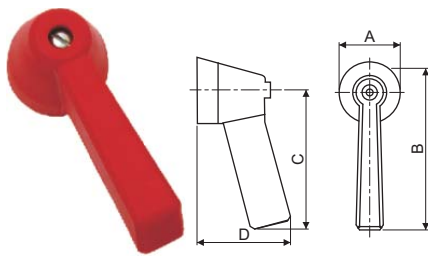

Code - PG	A	B	C	D
S16/TP16/RT16/TP20/RT20	36	102	82	56
S25/S32/RT25/RT32	36	102	82	56
S40/S63	36	102	82	56

BG - Ball Grip Handle

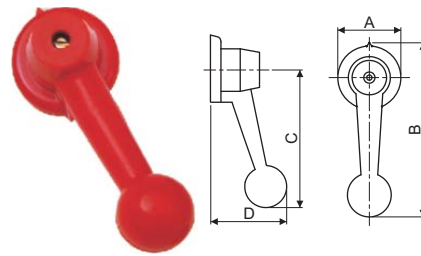

Code - BG	A	B	C	D
S16/TP16/RT16/TP20/RT 20	36	100	67	45
S25/S32/RT25/RT32	36	100	67	45
S40/S63	36	100	67	45

LV - Lever Handle

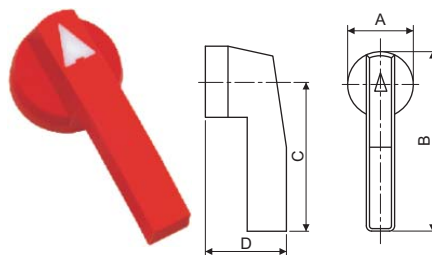

Code - LV	A	B	C	D
S80/S100/S125	50	115	90	45
S200/S400	50	115	90	45

All dimensions in mm.

Extended Terminals

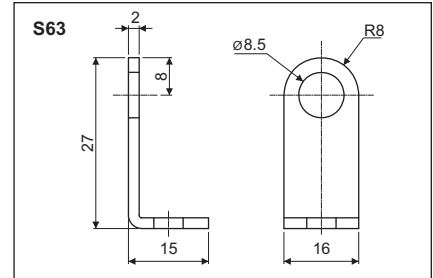
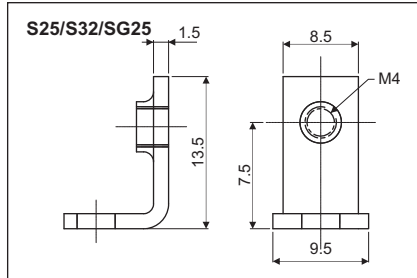
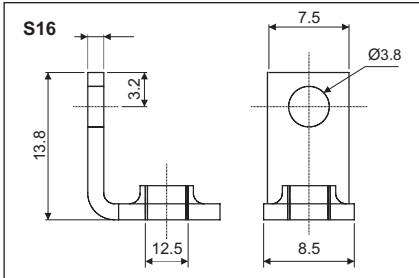

Supplied as optional for S40 and S63 on request

Extended Terminals - Always mounted on Switch

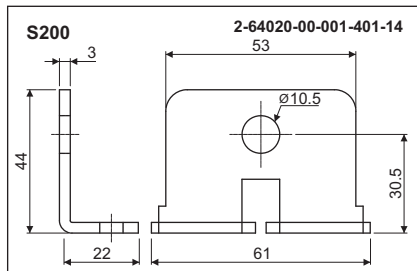
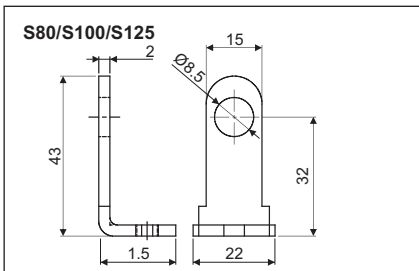

Always mounted on switch

Push on Terminals

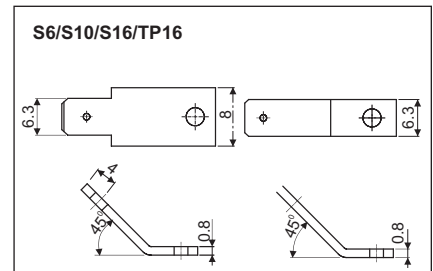

Mating terminal socket code no : 1653

Front Plate

Standard Style	Frame Size	Bigger Style
Current Ratings 6/10 Amps		---
16/20 Amps		6/10 Amps
25/32 Amps		16/20 Amps
S40 Amps & above		25/32 Amps
—		S40 Amps & above

Special Front Plates		
10 Amps 16 Amps 20 Amps		---
25/32 Amps		16/20 Amps

All dimensions in mm.

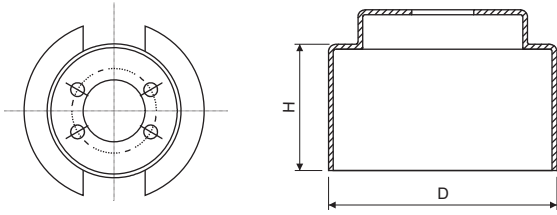
S-Series

Type	ØD	H	
		2 Stage	3 Stage
S6/S10	43 ^{+0.2}	25	34.5
S16/S25/S32	69 ^{+0.2}	35	50
S40/S63	95 ^{+0.2}	54	75

Other special size mounting plates at Front or Rear can be supplied against requirement.

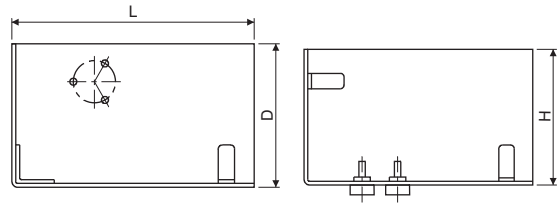
Rectangular

Type	L	D	H	No. of Stages
S40/S63	210	200	73	2
	210	200	94	3
S80 to S200	175	110	115	2
	210	200	100	2

In case of fixing at site use supplied hardware only.

The switch design and construction gives flexibility for making customized programme within a very short period. Basically an engineer trying to specify the customized programme should concentrate on the following points:

- Number of operating positions of switch handle.
- Total number of Contacts required.
- Contact closing sequence of all the contacts required in various positions of handle.



Note: Each position should be identified and Script plate marking required in those positions should be mentioned.

- The latching angle (angle between positions) Standard latching / switching angles are 600, 900, 450 & 300. Spring return are also possible for 450 & 900 switching angle.
- Total number of contacts can be decided based on the actual need. You may arrange the contacts to your convenience and number them as 1/2, 3/4, 5/6...etc.. While making the switch, we may rearrange the contacts to use solid jumpers so as to avoid loose wire jumpers.
- Fill up the programme sheet by marking 'X' at places where contacts have to Close (NC). Also ensure to specify the Ampere Rating, Mounting Style, Switching angle, Script Plate markings, Terminal marking & Lockable Position (If any).

For example, refer the sample customized programme sheet of a bedroom switch having 3 contacts controlling a tube-light, fan & night lamp.

Note: The above construction carries a five digit number starting with (7xxxx) allotted by us .This number alone is sufficient for future correspondence & further ordering.

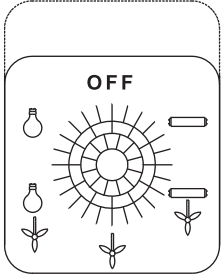
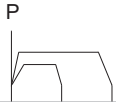
All dimensions in mm.

Front Plate	Programme Number	7 3 0 3 7																																															
	P																																																
	1 3 5	<table border="1" style="width:100%; border-collapse: collapse;"> <tr> <td style="width: 2.5%;">1</td><td style="width: 2.5%;">3</td><td style="width: 2.5%;">5</td><td style="width: 2.5%;">7</td><td style="width: 2.5%;">9</td><td style="width: 2.5%;">11</td><td style="width: 2.5%;">13</td><td style="width: 2.5%;">15</td><td style="width: 2.5%;">17</td><td style="width: 2.5%;">19</td><td style="width: 2.5%;">21</td><td style="width: 2.5%;">23</td><td style="width: 2.5%;">25</td><td style="width: 2.5%;">27</td><td style="width: 2.5%;">29</td><td style="width: 2.5%;">31</td><td style="width: 2.5%;">33</td><td style="width: 2.5%;">35</td> </tr> <tr> <td style="text-align: center;">/</td><td style="text-align: center;">/</td><td style="text-align: center;">/</td><td style="text-align: center;">/</td><td style="text-align: center;">/</td><td style="text-align: center;">/</td><td style="text-align: center;">/</td><td style="text-align: center;">/</td><td style="text-align: center;">/</td><td style="text-align: center;">/</td><td style="text-align: center;">/</td><td style="text-align: center;">/</td><td style="text-align: center;">/</td><td style="text-align: center;">/</td><td style="text-align: center;">/</td><td style="text-align: center;">/</td><td style="text-align: center;">/</td><td style="text-align: center;">/</td> </tr> </table>												1	3	5	7	9	11	13	15	17	19	21	23	25	27	29	31	33	35	/	/	/	/	/	/	/	/	/	/	/	/	/	/	/	/	/	/
	1	3	5	7	9	11	13	15	17	19	21	23	25	27	29	31	33	35																															
	/	/	/	/	/	/	/	/	/	/	/	/	/	/	/	/	/	/																															
	2 4 6 8 10 12 14 16 18 20 22 24 26 28 30 32 34 36																																																
2 4 6																																																	
Switching Angle 60°																																																	
Switching Positions																																																	
OFF	1																																																
	2																																																
	3																																																
	4																																																
TUBE	5	X																																															
	6																																																
	7																																																
	8																																																
TUBE & FAN	9	X X																																															
	10																																																
	11																																																
	12																																																
FAN	13																																																
	14																																																
	15																																																
FAN & LAMP	17	X X X																																															
	18																																																
	19																																																
NIGHT & LAMP	21	X																																															
	22																																																
	23																																																
	24																																																
																																																	
1	Switch Type	S 16				2	Mounting Form	BO3				3	Stop	with	without																																		
														X																																			
4	Front Plate	Type	Colour		7	Optional Extras																																											
		SO	Yellow																																														
5	Marking																																																
6	Handle	Type	Colour		Customer							Date																																					
		Tear Drop	Red																																														
Customer Code No.																																																	

Ordering Code Information

Programme Code | Type | Ampere | Mounting | Knob | Color

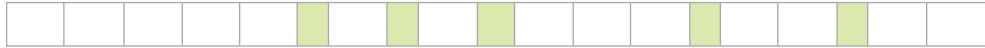

Example:- 6 1 1 9 7 S E B O 3 T D Y R

Programme Selector Table

Programmes	Prog Code
Isolators	Page 5
Changeovers with OFF	Page 6
Changeovers without OFF	Page 7
Multistep with OFF	Page 8
Multistep without OFF	Page 9
Instrumentation Switches	Page 10
Motor Control Switches	Page 12
Gang Switches	Page 14
Control Switches	Page 15

Type Selection

Type	Code	Possible Amps
S-Series	S	6 to 400 A
Touch Proof	T	6 to 16 A
Rear Termination	R	16 to 63 A
DC Switches	D	16 to 500 A
Phase Selector only for 1 pole 3 way with OFF	P	25 to 63 A

Ampere Selection

Ampere	Code
6	A
10	B
16	C
20	D
25	E
32	F
40	G
50	H
63	I
80	J
100	K
125	L
160	M
200	N
250	O
300	P
400	Q
500	R
600	S
800	T

Mounting Selection

For Mounting Styles
Refer Table on Page 16

Knob / Handle Selection

Code - TD	Code - FH	Code - PG	Code - BG	Code - LV
Tear Drop	Flag Knob	Pistol Grip	Ball Grip	Lever Handle

Color Combination Selection Table

Code - YR	Code - GB	Code - BB	Code - AB
Yellow Front Plate Red Knob	Grey Front Plate Black Knob	Black Front Plate Black Knob	Aluminum Foil with Black Knob

Under this 3 types are widely used

- a) Spring return
- b) Lost Motion contact (LMD)
- c) Sequence Locking (Two consecutive movement in one direction arrested)

All the above can also be with external KEY and LOCK arrangement.

In SPRING RETURN type the handle is always returns to NEUTRAL position and does not stay in other two positions, when the handle returns to Neutral, Main/TRIP contact will be in open condition.

In LMD, the contact block is divided into two, as main contacts and LMD contacts. LMD contacts will be closed when the handle moves to CLOSE side/TRIP side and the contact closing will be retained even though the handle is returned to NEUTRAL by virtue of Spring Return nature. When the handle is rotated in opposite direction only then LMD contact will open.

Thus the LMD mechanism enables the Switch to have a memory feature of the previous operation, which is considered to be very essential for circuit breaker applications.

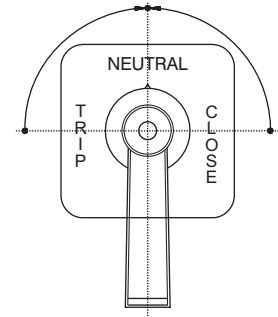

- Spring Return to Neutral Position from both sides
- Memory feature of previous operation (LMD)
- Permits only one Close operation (sequential lock)

In case of sequence lock, it acts like a mechanical interlock in the switch not permitting two consecutive 'CLOSE' operations. When you turn the handle to CLOSE position and handle will be back to NEUTRAL due to Spring Return action. Again the handle movement on the CLOSE side will be locked. When the handle is moved to TRIP position only then rotation to CLOSE position is permitted.

As indicated, all the above feature models can also be supported with external lock & key arrangement with key lockable and removable only at NEUTRAL position. Handle shall not be turned when the key is in lock condition.

Description		Unit	S25	S32
Rated Operational Voltage	Ue	V AC	690	690
		V DC	250	250
Resistance to Surge Voltage	Uimp	kV	6	6
Rated Uninterrupted Current	Ith	A	32	40
Rated Operational Current Pilot Duty AC15 le				
220-240 V AC		A	8	14
380-440 V AC		A	5	6
Short Circuit Protection HRC Fuse Size		A	25	32
Rated Short Circuit		kA	10	10
Terminal Cross Section				
Rigid Wire	min	mm ²	1.5	2.5
	max		4	6
Flexible Wire	min	mm ²	1	1.5
	max		2.5	4
Terminal Screw			M4	M4
Terminal Tightening Torque			1.2 Nm	1.2 Nm

General

Endurance :

Mechanical

100,000 operations at 300 cycles/hour

Electrical

10,000 operations at 120 cycles/hour
Operational Temperature 25°C to 55°C, frequency upto 5 kHz

Voltage	No. of Contacts in series	S25/SG 25				S32/SG32			
		Resistive Amps	Inductive L/R Amps			Resistive Amps	Inductive L/R Amps		
			10 msec	20 msec	40 msec		10 msec	20 msec	40 msec
50 V	1	20	20	15	6	25	25	18	8
	2	-	-	20	14	-	-	25	18
	3	-	-	-	20	-	-	-	25
125 V	1	3	2.5	1.5	1.0	5	3	2	1.2
	2	20	15	10	5	25	18	12	6
	3	-	20	20	10	-	25	v	12
250 V	1	1.0	0.5	0.3	0.2	1.2	0.6	0.4	0.3
	2	5	2	1.0	0.5	6	2.5	1.2	0.6
	3	20	10	4	1	25	12	5	1.2

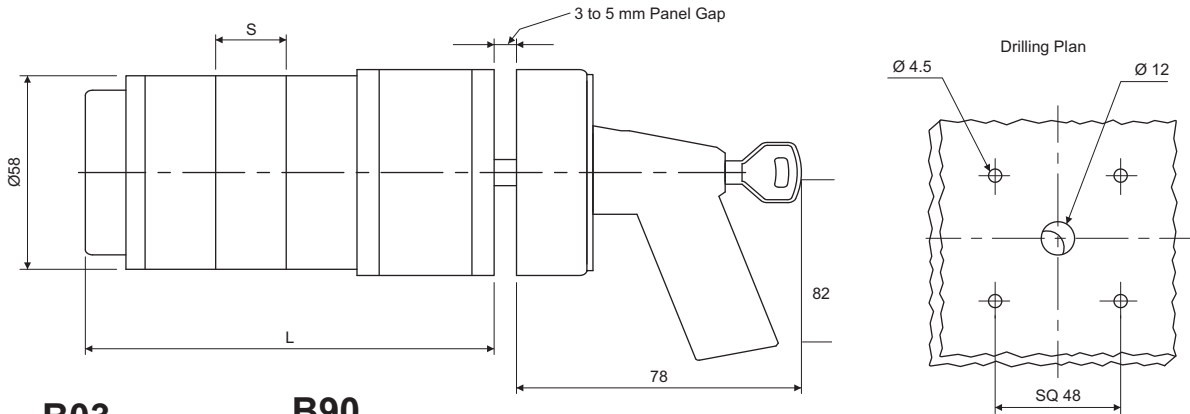

B03

B90

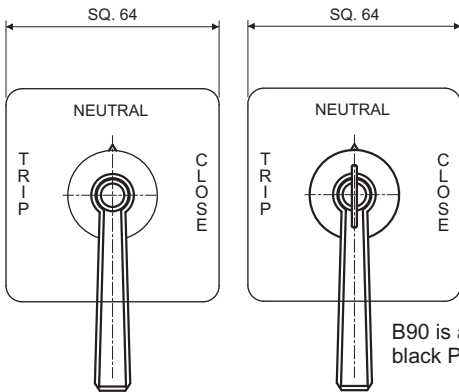

Shorter handle length also available on request

Type	L (No. of Stages)							X* LMD	Y* Sequential Lock
S25/S32	1	2	3	4	5	6	7	15	27.5
	53	68	83	98	113	128	143		

*LMD Dimension 'X' to be added
*Sequential Lock Dimension 'Y' to be added

B90 is available only black front plate & black PG handle type

Breaker Control Ordering Code

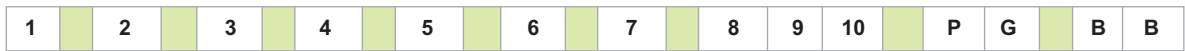

Example:- 1 Q S L 1 1 E B 9 0 P G B B

25 Ampere Spring return TNC with 1 set of Main contact 1NO+1NC, 1 LMD contact in Trip position & 1 LMD contact in Close position with Sequential locking and Barrel lock mounting

Digit 1

No. of Main Contacts in Trip / Close Position	
Description	Code
1 NO+1 NC	1
2 NO+2 NC	2
3 NO+3 NC	3
4 NO+4 NC	4
5 NO+5 NC	5
6 NO+6 NC	6
7 NO+7 NC	7
8 NO+8 NC	8
9 NO+9 NC	9

Digit 2

Sequence Locking	Code
If required	Q
Not required	O

Digit 3

Latching Mechanism	Code
Spring Return	S
Stayput	C

Digit 4

LMD Contacts	Code
If required	L
Not required	D

Digit 5

No. of LMD Contacts in Trip Position	
Description	Code
1 Contact	1
2 Contact	2
3 Contact	3
4 Contact	4
5 Contact	5
6 Contact	6
If not required	0

Digit 6

No. of LMD Contacts in Close Position	
Description	Code
1 Contact	1
2 Contact	2
3 Contact	3
4 Contact	4
5 Contact	5
6 Contact	6
If not required	0

Digit 7

Ampere Rating	Code
25 Ampere	E
32 Ampere	F

Digit 8, 9, 10

Mounting	Code
Standard Front Mounting	B03
Barrel Lock with Center Key	B90

All dimensions in mm.

Cam Operated Rotary Switch

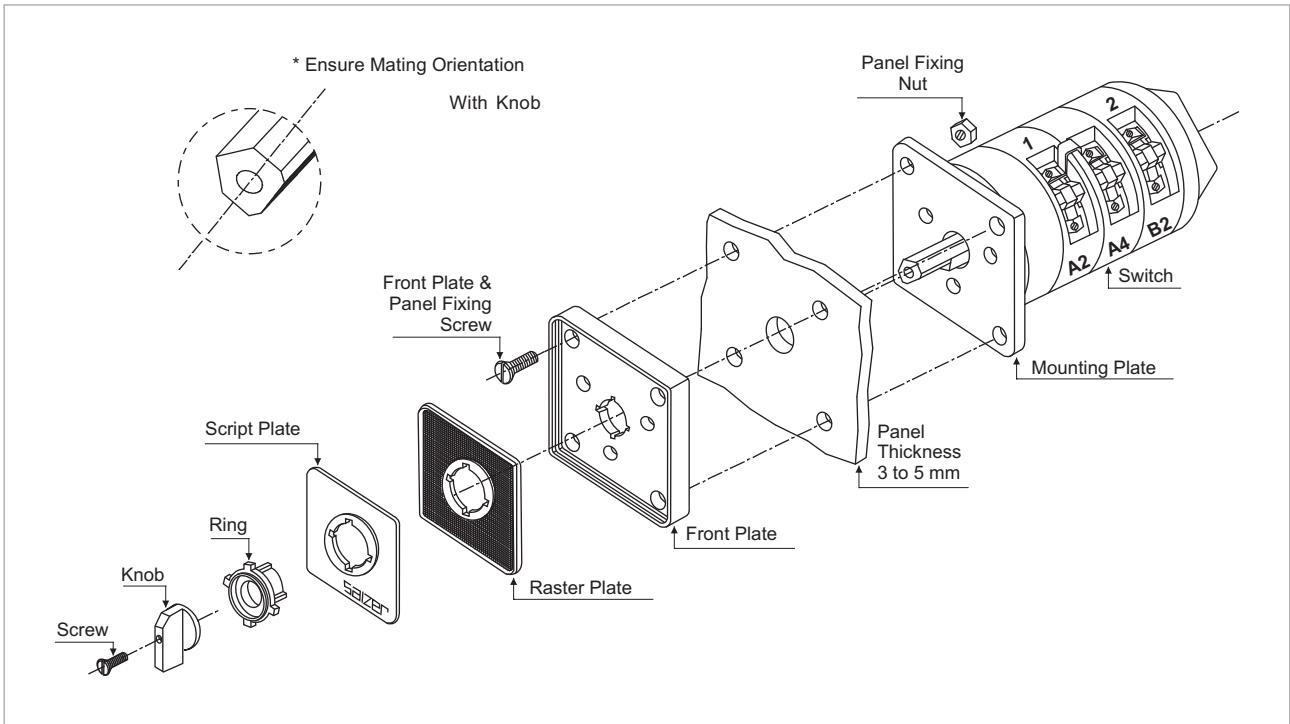

Breaker Control Switch

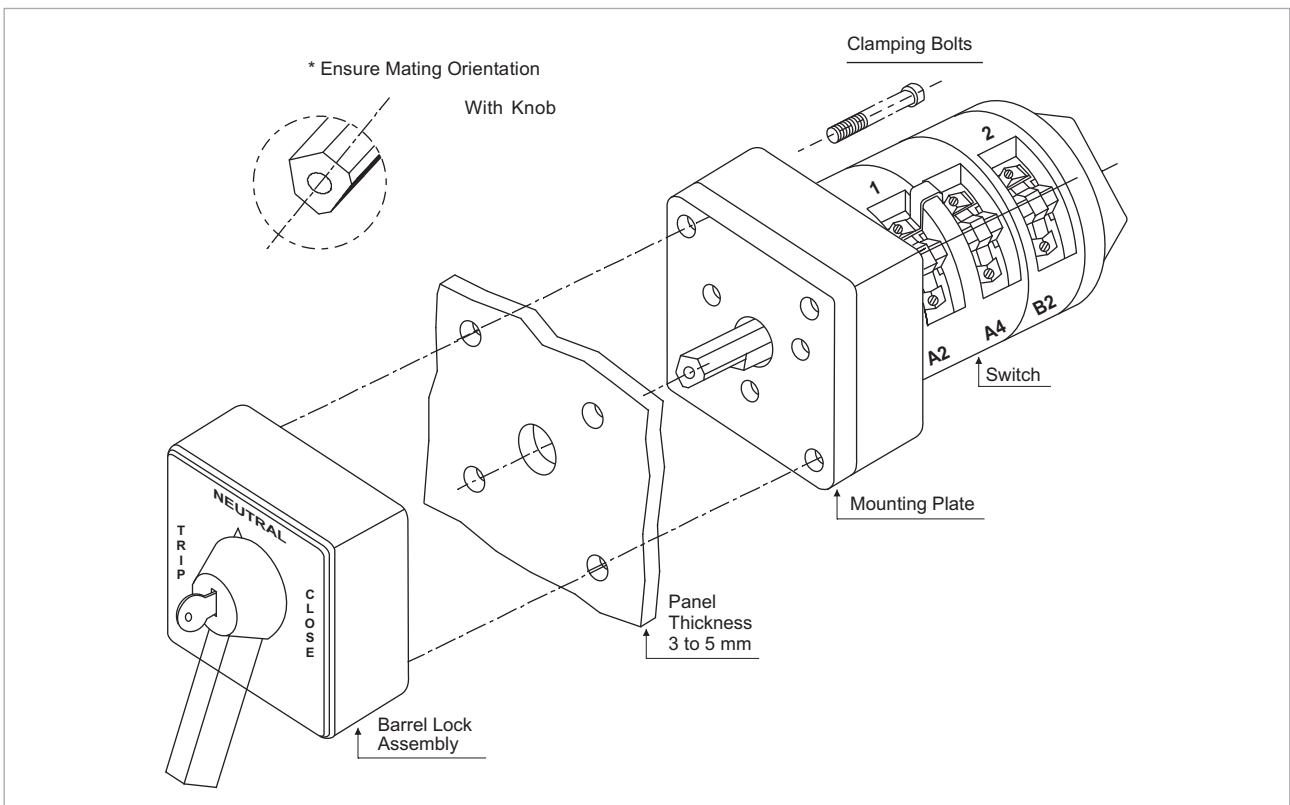

All dimensions in mm.

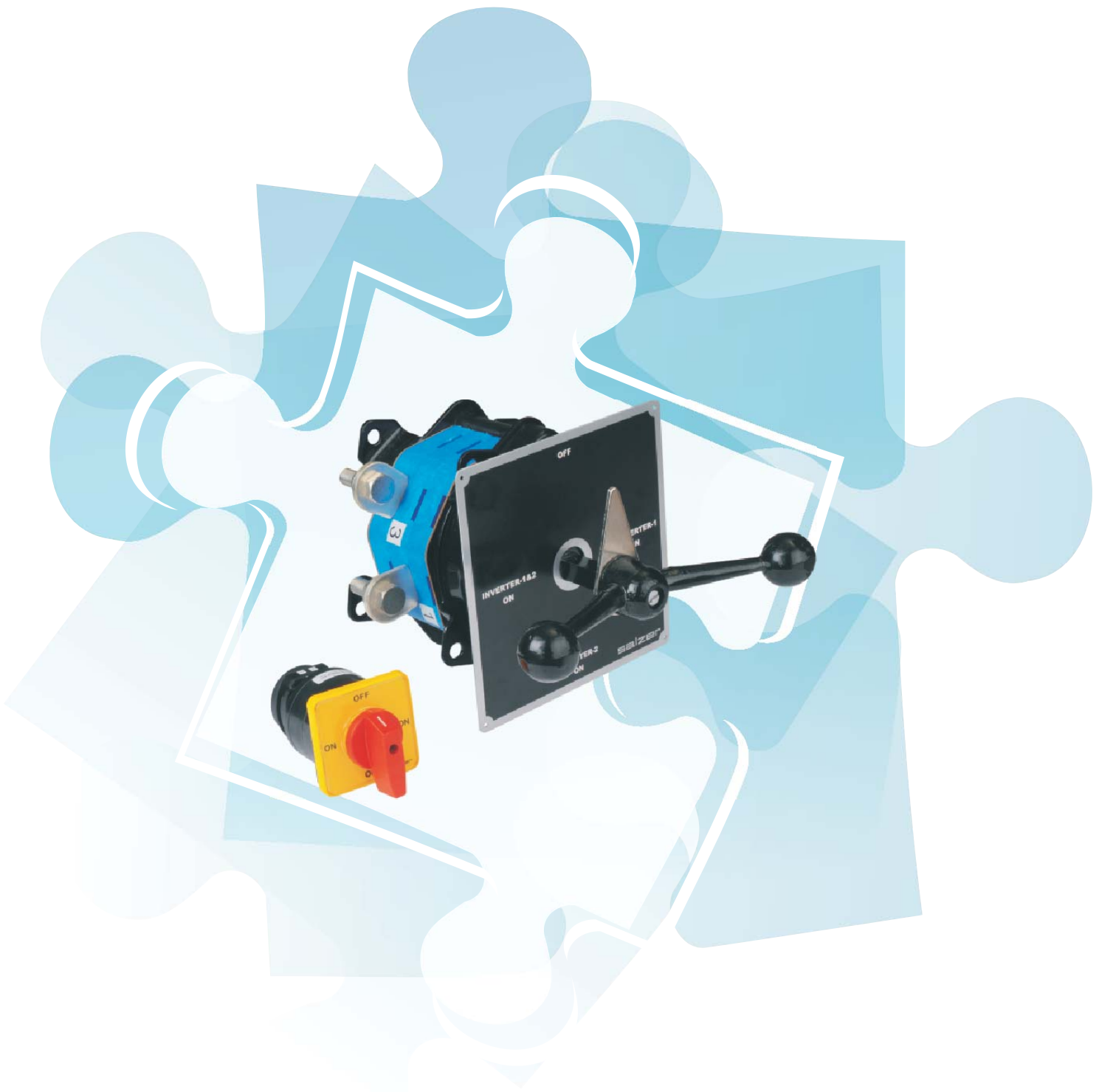

DC Rotary Switches

Construction and Features

D16 - D63

D Series Switches are designed for DC switching applications. These switches are constructed using snap action mechanism which provides 'Quick Make Quick Break' of contacts which is essential for DC switching. The contacts are of AgCdO, double break and butt type housed in a glass filled polyamide contact stage and are operated through cams for higher electrical endurance and smooth operation.

Suitable for 90 and 60 degree switching programmes and applicable for both AC and DC switching. Suitable switching programmes for Isolator, Changeover, Multistep and Gang Switches etc. are offered.

DC Switches D100 A - D500 A

Features:

- Housing made up of SMC material for rigidity and higher mechanical strength
- 'Wiping contacts' operations helps in dust free & self cleaning concepts
- Extended terminals for Bus bar / Aluminium cable connections
- Capstone handle operation for better leverage

Applications:

- D40R - Railway coaches lighting & fan circuits switching
- All DC power circuits - Railways, Telecommunications & Power plants
- Battery charging equipment

DC Ratings	Description		Unit	Rated Operational Current I _e				
				Switch Type				
				D 16	D 25	D 32	D 40	D 63
Rated on Interrupted Current (I _{th})			A	20	32	40	50	80
DC 22A L/R 2m sec								
Rated Operational Voltage	110 V	250 V	A	16	25	32	40	63
No of Series Contacts	1	2						
AC Ratings	AC3 Rating 3 Phase	380-440 V	HP	7	10	14	20	25
	AC21 Rating		A	16	25	32	40	63
General	Fuse Protection		A	16	25	32	40	63
	Short Circuit Through Fault Current		kA	5	10	10	20	20
	Terminal	[Rigid] min	mm ²	1.5	1.5	1.5	1.5	1.5
	Cross Section	[Flex] max	mm ²	4	4	6	10	16
	Tightening Torque		Nm	0.8	1.2	1.2	2	2
Maximum Contact Stages				16	10	10	6	6
Description			Unit	D 100	D 200	D 300	D 400	D 500
Duty Rating - DC 22 A L/R 2m sec								
Operational Voltage			V DC	250	250	250	250	250
Voltage for AC Rating			V AC	460	460	460	460	460
Operational Current			A	100	200	300	400	500
Thermal Current (I _{th})			A	125	250	375	500	625
Switching Angle			Deg	90	90	90	90	90
Maximum Contact Stages				9	9	9	9	9

D16 D63

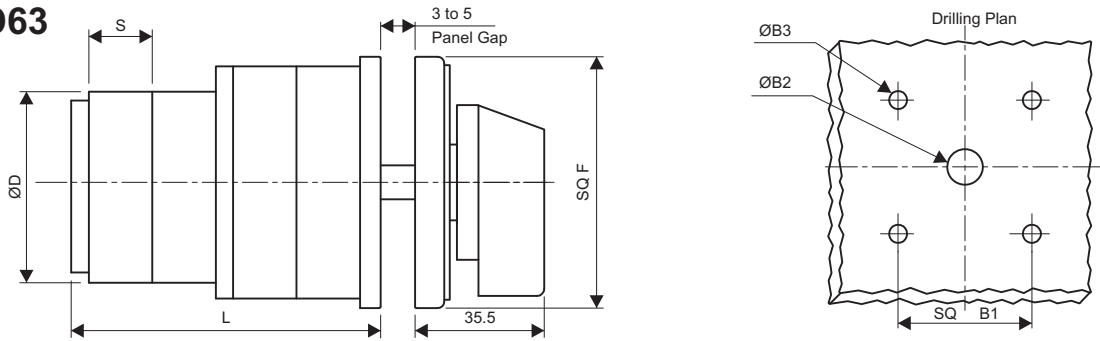

Type	B1	B2	B3	D	F	S
D16	48	12	5.5	50	64	12
D25/D32	48	12	5.5	50	64	15
D40/D63	68	15	5.5	70	88	21

Stages		1	2	3	4	5	6	7	8	9	10	11	12
		Length L in mm	D16	62	74	86	98	110	122	134	146	158	170
	D25/32	65	80	95	110	125	140	155	170	185	200	215	230
	D40/63	69	90	111	132	153	174	195	216	237	258	279	300

D40 R

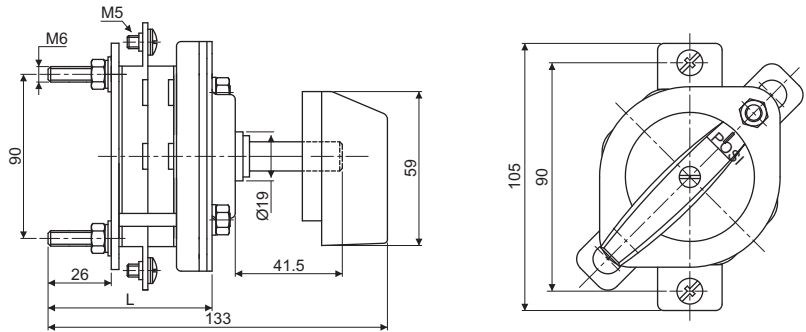

Type	S	S1	S2	Length L							
				1	2	3	4	5	6	7	8
D40	10	30.5	15	55.5	65.5	75.5	85.5	95.5	105.5	115.5	125.5

L = No. of Stages x S + (S+S)

D100

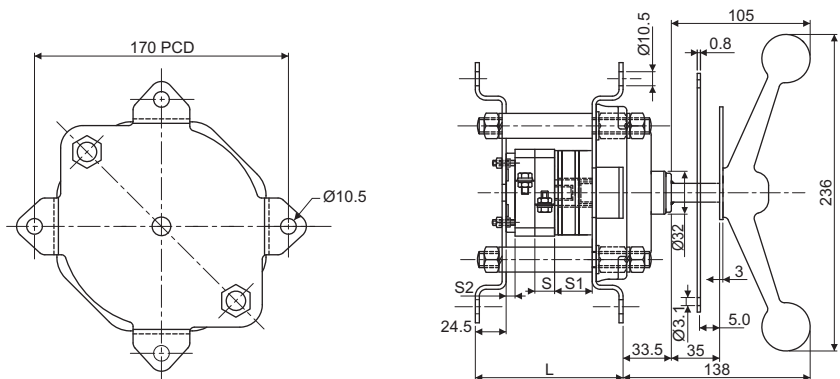

Type	S	S1	S2	Length L						
				1	2	3	4	5	6	7
D100	32	32	15	112	144	176	208	240	272	304

All dimensions in mm.

D200-D500

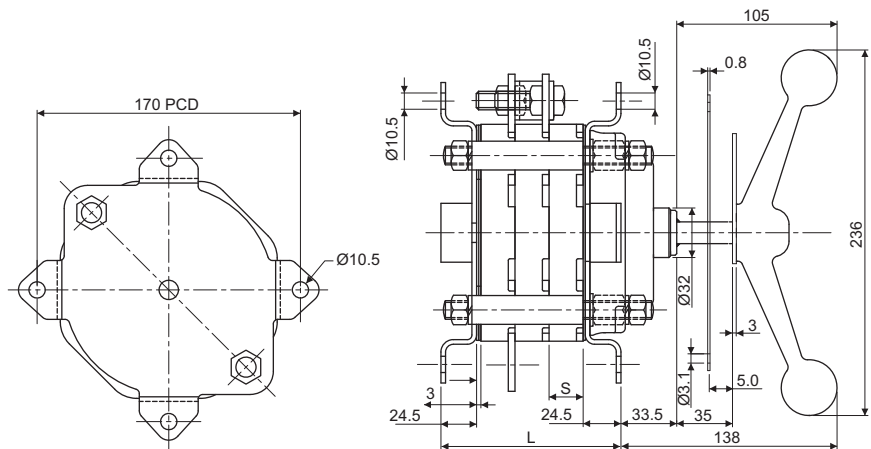

Type	S	Length L				
		3	4	5	6	7
D200-D500	22	117	139	161	183	205

D100 with Door Interlock

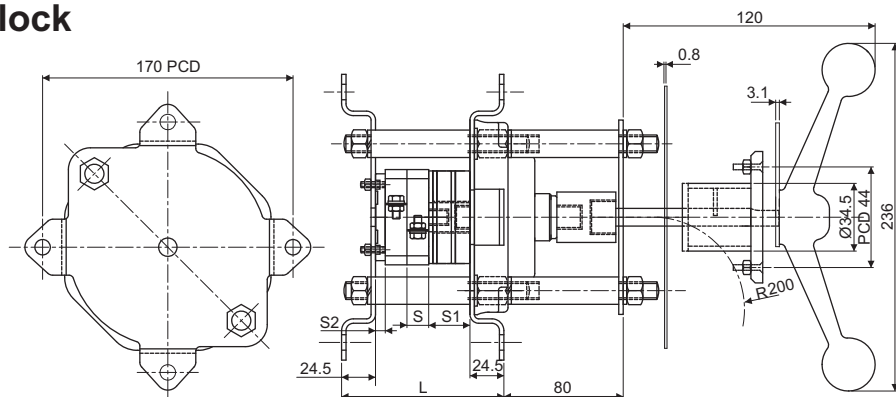

Type	S	S1	S2	Length L							
				1	2	3	4	5	6	7	8
D100	32	35	15	210	242	274	306	338	370	402	434

D200-D500 with Door Interlock

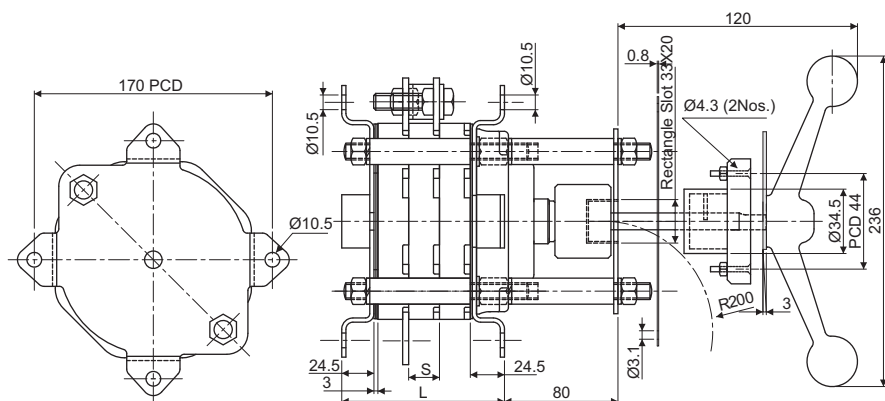

Type	S	Length L				
		3	4	5	6	7
D200-D500	22	197	219	241	263	285

All dimensions in mm.

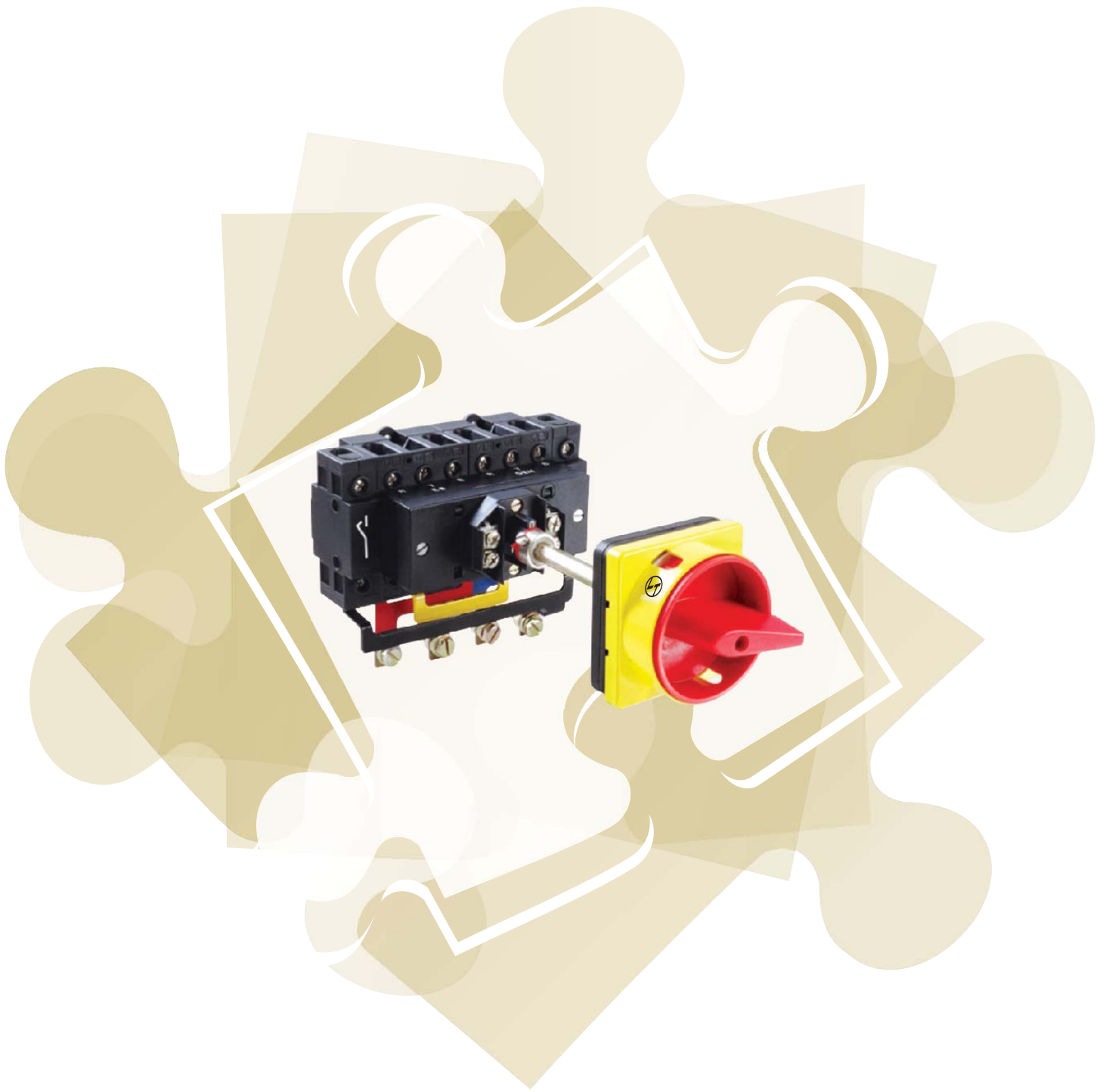

Load Break Switches

Technical Data

European Standard	IEC 60947-1 & 3, EN 60947, VDE 0660-107
-------------------	---

Rating	Measure		LB116	LB120	LB225	LB232	LB240	LB263	LB4080	LB4100	LB4125	
Rated Operational Voltage, U_e												
IEC/EN/VDE 50 Hz, AC	Volts	V	380-440	380-440	380-440	380-440	380-440	380-440	380-440	380-440	380-440	
UL/CSA 50 Hz, AC	Volts	V	600	600	600	600	600	600	600	600	600	
Main Switch: Isolating Voltage upto	Volts	V	750	750	750	750	750	750	750	750	750	
Resistance to Surge Pulse Voltage, U _{imp}	Volts	kV	6	6	6	6	6	6	6	6	6	
Rated Operational Current, I_e												
IEC/EN/VDE, AC 23 A	Amp	A	16	20	25	32	40	63	80	100	125	
Short Circuit Size (IEC/EN/VDE)												
Max. Fuse Size (Type gL)	Amp	A	16	25	25	32	40	63	80	100	125	
Rated fused short circuit current	Amp	kA	5	5	30	30	30	30	30	30	30	
UL/CSA Power Rating: Manual Motor Control, Suitable as Disconnect												
DOL 50 Hz, AC	3 Phase, 3 Pole	120V	HP	1.5	1.5	3	3	5	7.5	5	7.5	7.5
		240V	HP	3	3	7.5	7.5	10	15	20	20	30
		480V	HP	7.5	7.5	15	20	20	25	30	30	40
		600V	HP	10	10	20	25	30	30	40	40	50
	1 Phase	120V	HP	0.5	0.5	1.5	2	3	3	3	3	3
		240V	HP	1.5	1.5	2	3	4	7.5	7.5	7.5	7.5
Short Circuit Capacity (UL/CSA)												
Max. Fuse Size	Amp	A	25	25	50	50	70	70	100	100	125	
Fuse Rating, J Type	Amp	A	20	20	45	45	70	70	125	125	125	
Rated Fused Short Circuit Current	Amp	kA	10	10	10	10	10	10	10	10	10	
Terminal Cross Section												
Single/Multiple Strand Wire	Min-mm ²		1.5	1.5	1	1	4	4	6	6	6	
	Max-mm ²		6	6	10	10	16	16	70	70	70	
Fine-Strand Wire with Sleeve	Min-mm ²		0.5	0.5	0.75	0.75	2.5	2.5	4	4	4	
	Max-mm ²		6	6	6	6	10	10	50	50	50	
American Wire Gauge	AWG		12	12	8	8	6	6	1	1	1	
Recommended Tightening Torque	Nm		0.8	0.8	1.7	1.7	2.0	2.0	2.5	2.5	2.5	

Switches: LB225, LB232, LB240, LB263, LB4080, LB4100, LB4125

	3 Pole	1 Pole + 1 Main Module	4 Pole + 1 Main Module	6 Pole	8 Pole
	31300	31400	31500	31600	31800
	31309	31409	31509	31609	31809

	3 Pole + 1 Neutral Module	4 Pole + 1 Neutral Module	3 Pole + 1 Auxilliary Module	4 Pole + 1 Auxilliary Module	3 Pole + 2 Neutral Module	3 Pole + 2 Auxilliary Module
	31310	31410	31320	31420	31330	31340
	31319	31419	31329	31429	31339	31349

Note: 6P and 8P for LB116 and LB120 are under development. Please refer to us

Switches: LB4080, LB4100, LB4125

	31309	31409	31509	31609	31809

	31319	31419	31329	31429	31339	31349

B03



16 A-20 A

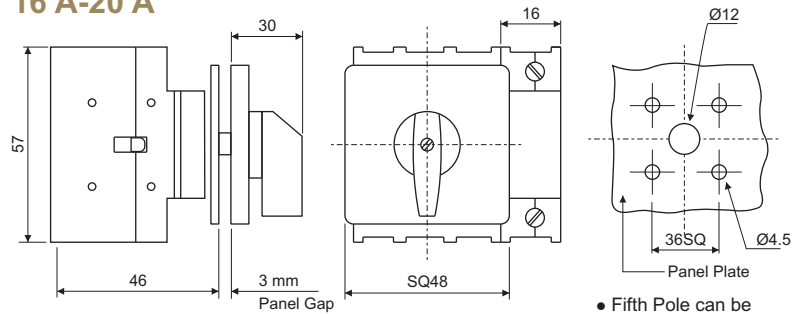

- 4 Hole front panel mounting
- Degree of protection : Front IP55

• Fifth Pole can be fitted on the other side of the switch

B19



16 A-20 A

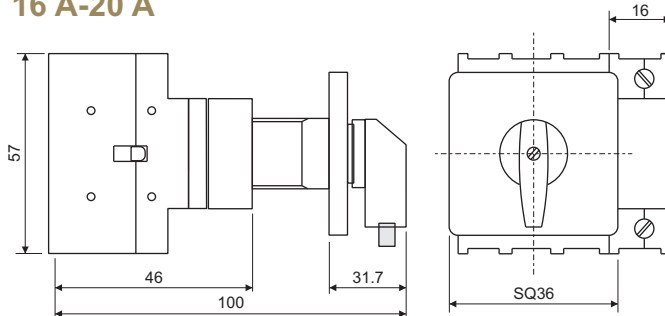

- Dia 22.5 mm, single hole panel mounting
- Degree of protection : Front IP55
- Switch with padlockable flag knob
- Maximum 1 padlock

B40



16 A-20 A

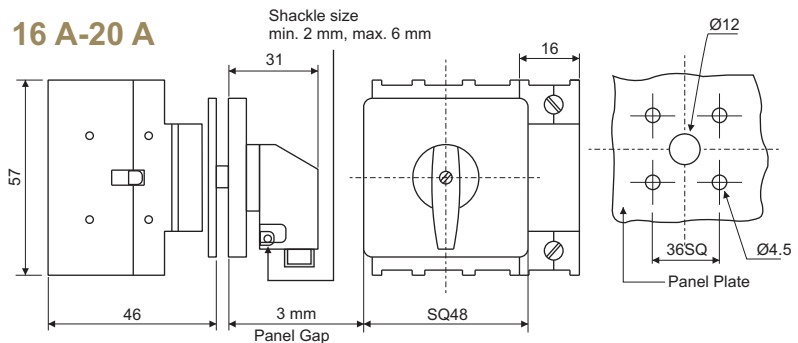

- 4 Hole, front panel mounting
- Degree of protection : Front IP55

- Switch with padlockable flag knob
- Maximum 1 padlock

B13



25 A-63 A

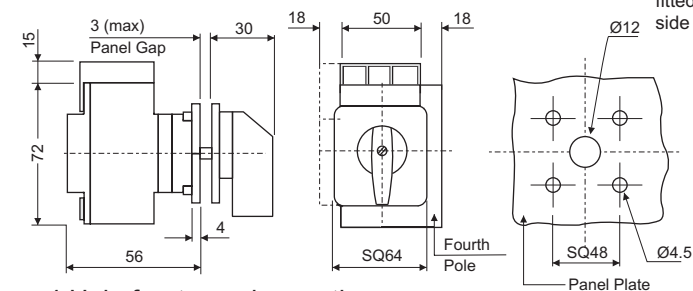

- 4 Hole front panel mounting
- Degree of protection : Front IP55

• Fifth Pole can be fitted on the other side of the switch

All dimensions in mm.

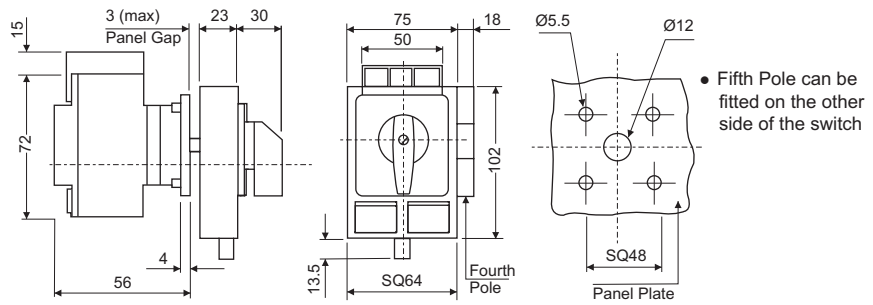
B30**25 A-63 A**

- 4 Hole front panel mounting
- Degree of protection : Front IP55
- Switch with rectangular padlocking device to prevent the switch from being switched ON by unauthorized personnel
- Max 4 padlocks

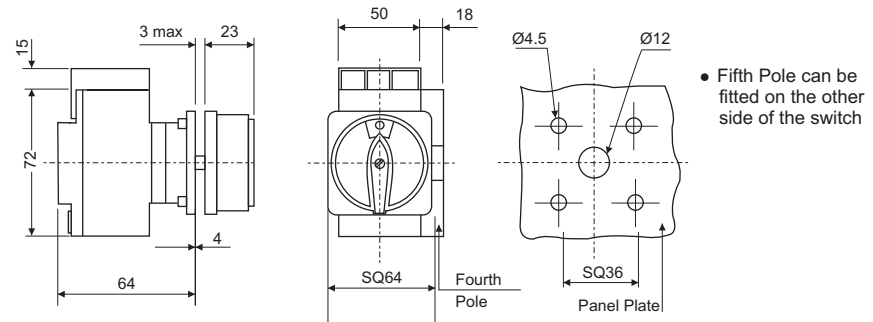
B33**25 A-63 A**

- 4 Hole front panel mounting
- Degree of protection : Front IP65
- Switch with round padlocking device to prevent from being switched ON by unauthorized personnel
- Max 3 padlocks

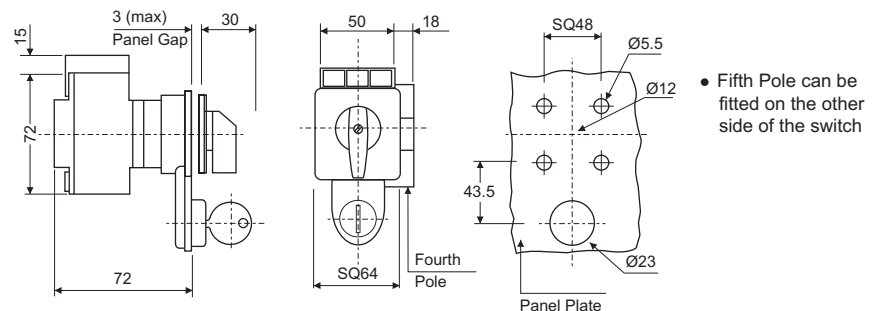
B63**25 A-63 A**

- 4 Hole front panel mounting
- Degree of protection : Front IP55
- Knob operated, keylock, key removable in OFF position (other options on request)

All dimensions in mm.

B23



- 2 Hole rear mounting
- Alternately snap mounting on DIN EN50022 rail (35 mm)
- Degree of protection : Front IP30

25 A-63 A

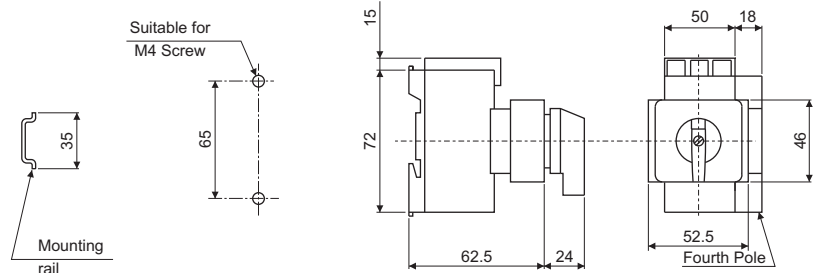

80 A-125 A

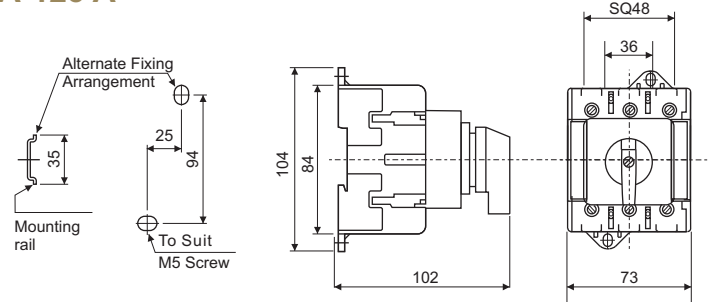

MB42



- 2 Hole rear mounting or snap mounting on DIN EN50022 rail (35 mm) can be operated from the front (door) - coupled with door mechanism
- Door interlock (Door openable only in OFF position)
- Degree of protection : Front IP55

16 A-20 A

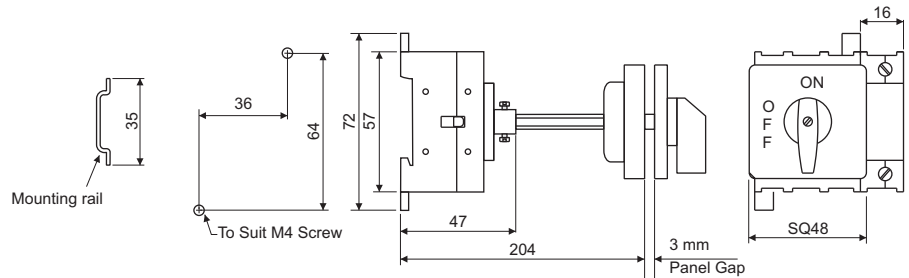

25 A-63 A

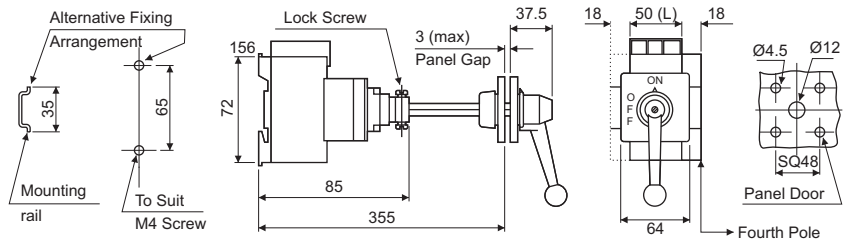

80 A-125 A

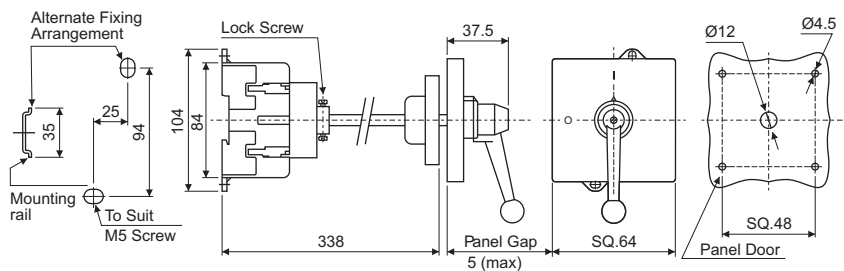

All dimensions in mm.

MB34



- 2 Hole rear mounting or snap mounting on DIN EN50022 rail (35 mm) can be operated from the front (door) coupled with door mechanism
- Door interlock (Door openable only in OFF position)
- Degree of protection : Front IP65
- Rigid metal shaft / switch assembly
- Switch with round padlocking device to prevent the Switch from being made ON by unauthorized persons
- Max. 3 padlocks as under :
 16 A-20 A : Max. 1 padlock
 25 A-63 A : Max. 2 padlocks
 80 A-125 A : Max. 3 padlocks

16 A-20 A

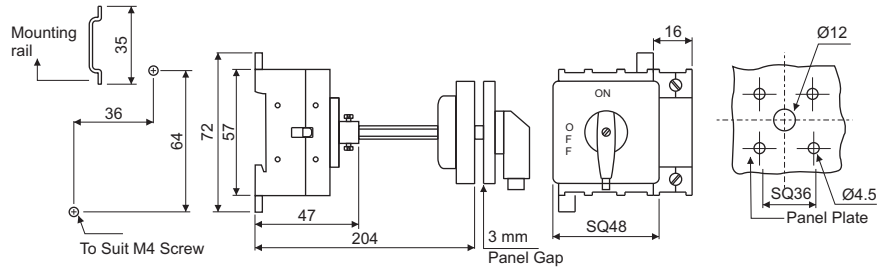

25 A-63 A

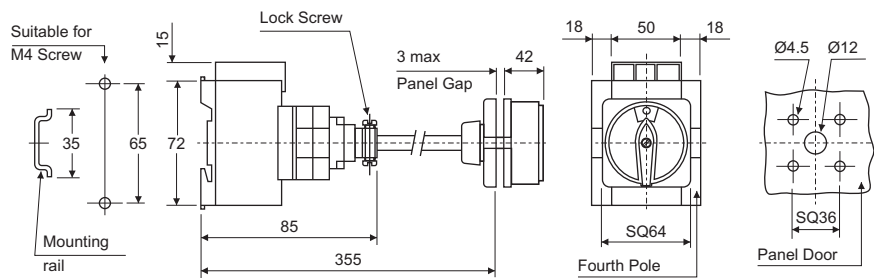

80 A-125 A

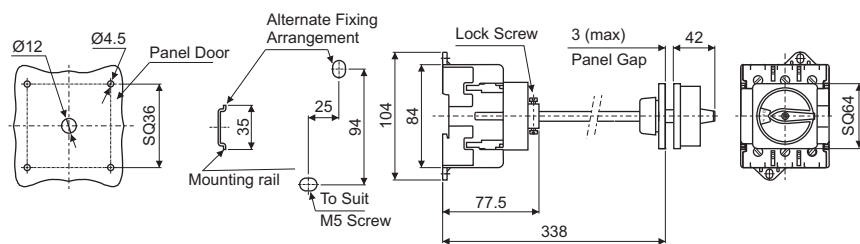

- Adjustable mounting by cutting the metal shaft to appropriate length, to suit panel height
- Specific length of shaft can be offered on request

All dimensions in mm.

B31SM



16 A-32 A

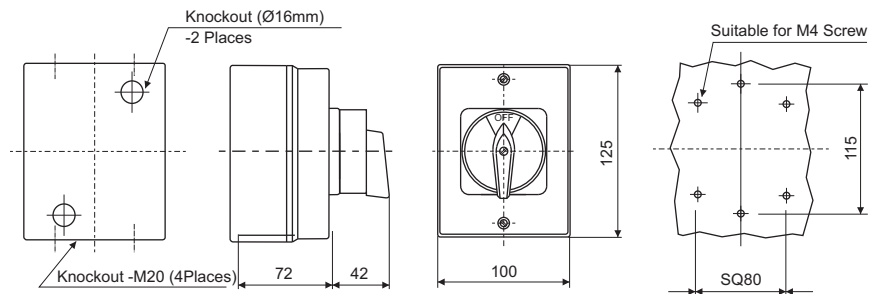

- Switch mounted in ABS / polycarbonate (optional) enclosure
- Round padlocking device (max. 3 padlocks) to prevent the switch from being made ON by unauthorized personnel
- Knob version available on request

- Switch rear mounted for easy connection
- Degree of protection : IP65
- Red / Yellow-handle colour for Main / Emergency switches
- Enclosure colour : Dark grey base and light grey cover
- Door Interlock

B31M



40 A-63 A

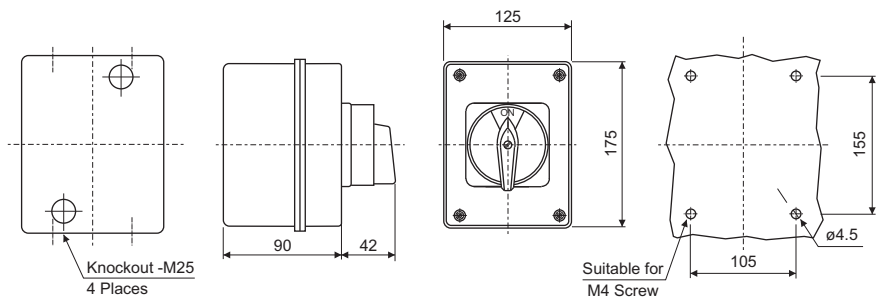

- Switch mounted in ABS enclosure, optional in polycarbonate

- Round padlocking device (max. 3 padlocks) to prevent the Switch from being made ON by unauthorized personnel
- Degree of protection : IP65
- Switch rear mounted for easy connection

- Red / Yellow-handle colour for Main / Emergency Switches
- Enclosure colour : Dark grey base and light grey cover
- Door Interlock

B31L



80 A-125 A

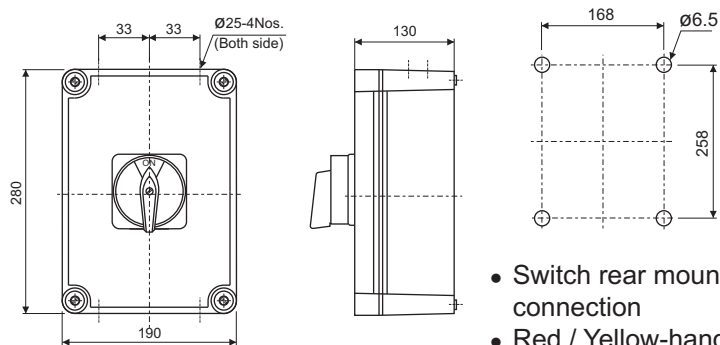

- Switch mounted in ABS / polycarbonate (optional) enclosure

- Padlocking device (max. 3 padlocks) to prevent the Switch from being made ON by unauthorized personnel
- Degree of protection : IP65

- Switch rear mounted for easy connection
- Red / Yellow-handle colour for Main / Emergency switches
- Interlock provided to open the lid only in OFF position
- Enclosure colour : Grey
- Door Interlock

All dimensions in mm.

AB31S



16 A-20 A

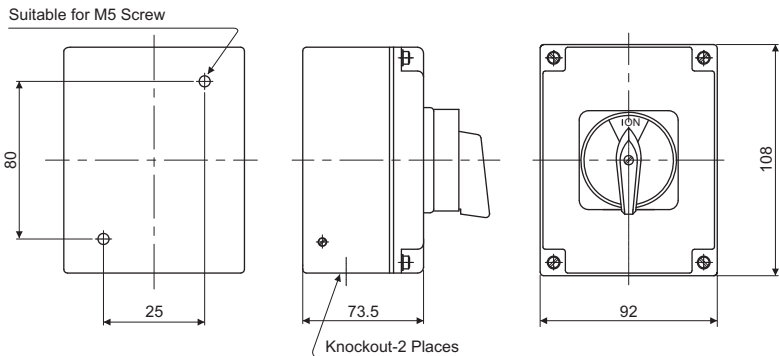

- Switch mounted in aluminium enclosure
- Round padlocking device (max. 3 padlocks) to prevent the switch from being made

- ON by unauthorized personnel
- Degree of protection : IP65
- Red / Yellow-handle colour for Main / Emergency switches

- Enclosure colour : Dark grey base and light grey cover
- Door Interlock

AB31M



25 A-63 A

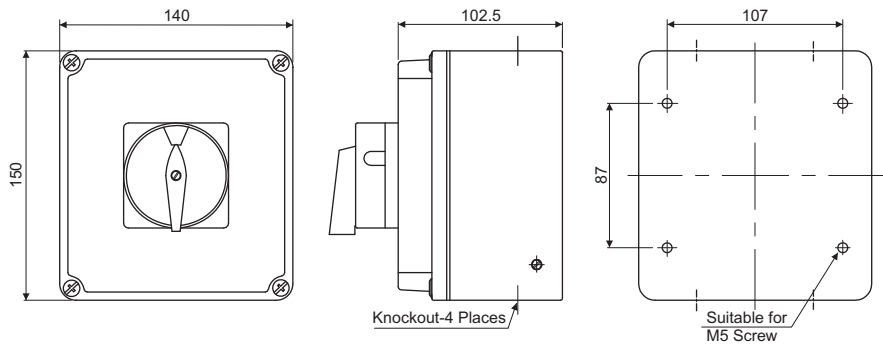

- Switch mounted in aluminium enclosure
- Round padlocking device (max. 3 padlocks) to prevent

- the switch from being made to ON by unauthorized personnel
- Degree of protection : IP65
- Red / Yellow-handle colour for

- Main / Emergency switches
- Enclosure colour : Dark grey base and light grey cover
- Door Interlock

AB31L



80 A-125 A

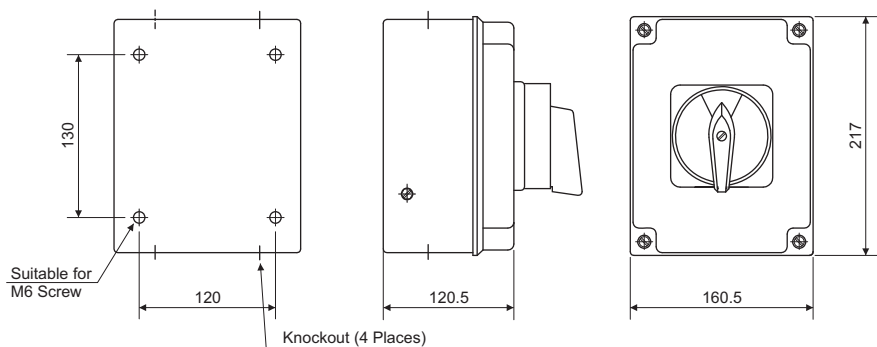

- Switch mounted in aluminium enclosure
- Round padlocking device (max. 3 padlocks) to prevent the Switch

- from being made ON by unauthorized personnel
- Degree of protection : IP65
- Red / Yellow-handle colour for Main / Emergency switches

- Enclosure colour : Dark grey base and light grey cover
- Door Interlock

All dimensions in mm.

SB31S



Upto 25 A

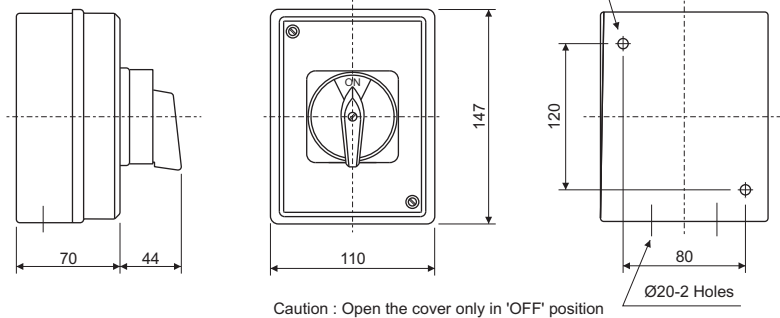

- Switch mounted in Steel enclosure
- Round padlocking device (max. 3 padlocks) to prevent the Switch from being made ON by

- unauthorized personnel
- Degree of protection : IP53*
- Knob version available on request
- Red / Yellow-handle colour for

- Main / Emergency switches
- Enclosure colour : Dark grey base and light grey cover
- Door Interlock

SB31M



32 A - 63 A

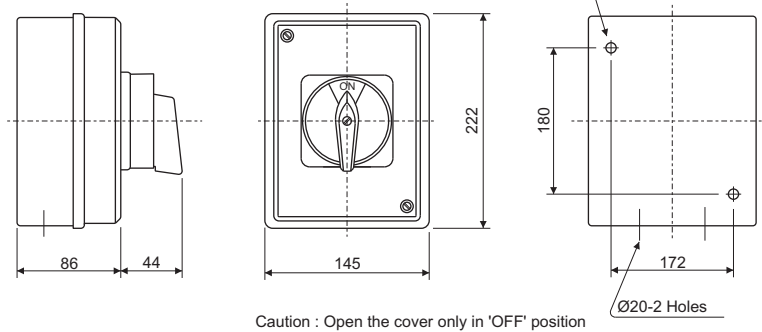

- Switch mounted in Steel enclosure
- Round padlocking device (max. 3 padlocks) to prevent the Switch from being made ON by

- unauthorized personnel
- Degree of protection : IP53
- Knob version available on request
- Red / Yellow-handle colour for

- Main / Emergency switches
- Enclosure colour : Dark grey base and light grey cover
- Fourth pole can be added
- Door Interlock

SB31L



80 A-125 A

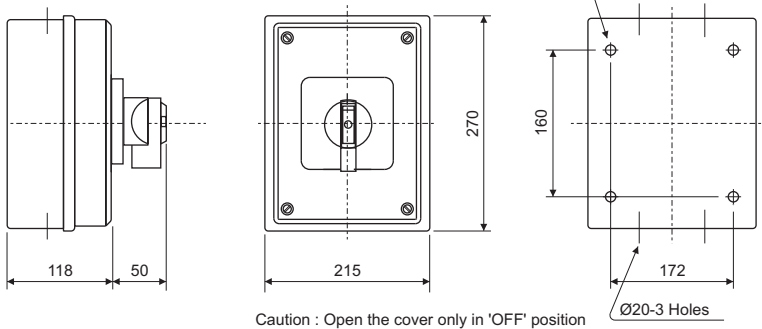

- Switch mounted in Steel enclosure
- Round padlocking device (max. 3 padlocks) to prevent the Switch from being made ON by unauthorized personnel

- Degree of protection : IP53
- Knob version available on request
- Red / Yellow-handle colour for Main / Emergency switches

- Enclosure colour : Dark grey base and light grey cover
- Fourth pole can be added
- Door Interlock

All dimensions in mm.

**Add on Main Pole
(16 A-63 A)**



For Switch Code	Code for Front Mounting Switch	Code for Rear Mounting Switch
LB116	LB120	LB120
LB120	FMC20	RMC20

For Switch Code	Code for Front Mounting Switch	Code for Rear Mounting Switch
LB225	LB232	LB232
LB232	FMC32	RMC32
LB240	LB263	LB263
LB263	FMC63	RMC63

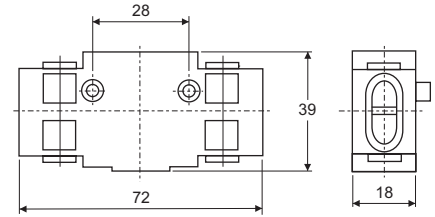
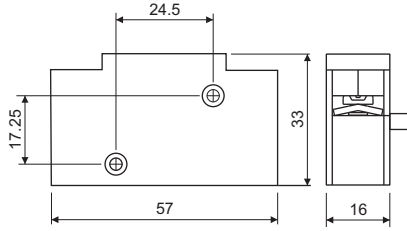

- Equivalent switch electrical rating
- Used as 4th / 5th pole on either side of the switch

**Add on Main Pole
(80 A-125 A)**



For Switch Code	Code for Rear Mounting Switch	Code for FM Switch
LB4080		
LB4100	LB4125	LB4125
LB4125	RMC125	FMC125

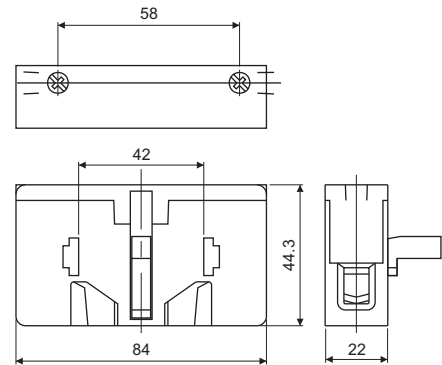

- Equivalent switch electrical rating
- Used as 4th / 5th pole on either side of the switch

Applications

For switching action of additional pole, when mounted with the switch. The additional pole on either side of the switch can be used to switch on any single phase requirements simultaneously.

**Add on Neutral Pole
(16 A-63 A)**



For Switch Code	Code for Front Mounting Switch	Code for Rear Mounting Switch
LB116	LB120	LB120
LB120	FNC20	RNC20

For Switch Code	Code for Front Mounting Switch	Code for Rear Mounting Switch
LB225	LB232	LB232
LB232	FNC32	RNC32
LB240	LB263	LB263
LB263	FNC63	RNC63

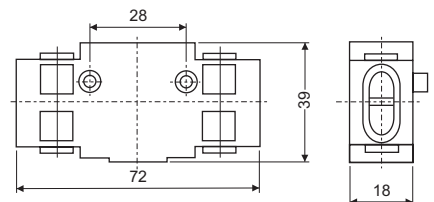
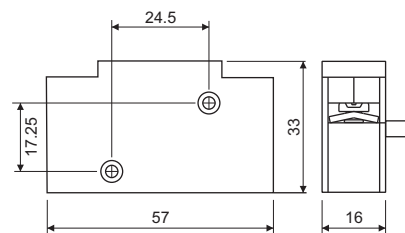

- Early make late break contact
- Can be fitted on either side of the switch

Applications

To be used as Neutral Conductor to the switch.

All dimensions in mm.

Add-on Neutral Pole (80A-125A)



- Early make late break contact
- Can be fitted on either side of the switch

Applications

To be used as Neutral Conductor to the switch.

For Switch Code	Code for Rear Mounting Switch	Code for Front Mounting Switch
LB4080	LB4125 RNC125	LB4125 FNC125
LB4100		
LB4125		

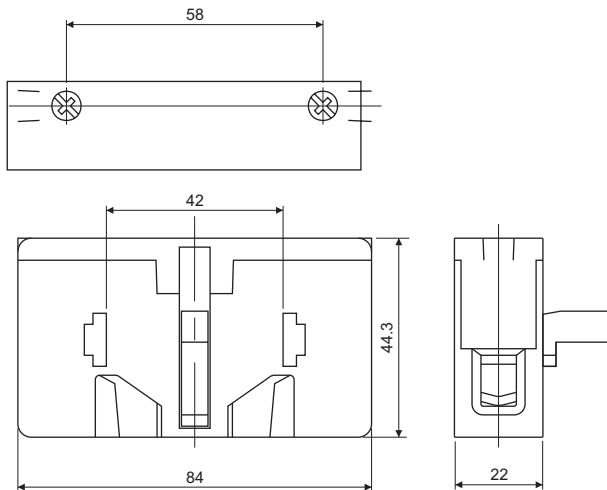

Add-on Auxiliary Pole



- 1NO contact early break / late make + 1NC contact
- Can be fitted on either side of the Switch

Applications

Auxiliary contact module has two contacts, 'NO and NC'. 'NO' contact is early break, late make contact. This is used to trigger any auxiliary circuits.

For Switch Code	Code for Front Mounting Switch	Code for Rear Mounting Switch
LB116	LB120 FAC16	LB120 RAC16
LB120		
LB225	LB263 FAC16	LB263 RAC16
LB232		
LB240		
LB263		
LB4080	LB4125 FAC16	LB4125 RAC16
LB4100		
LB4125		

Rating

IEC / EN	16A, 500V	
AC-15	220-240V 380-440V	6A 4A

Terminal Cross Section

Single/Multiple Strand Wire	min. mm ²	1.0
	max. mm ²	1.5
American Wire Gauge	AWG	16

LB116-LB120

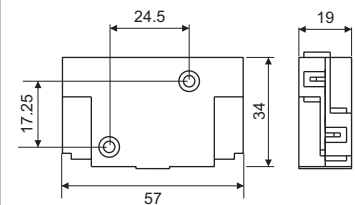

LB225-LB263

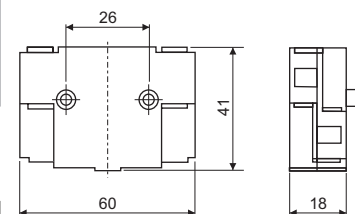

LB4080-LB4125

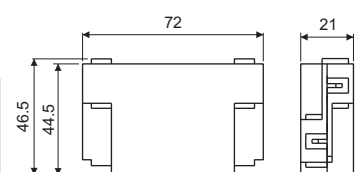

All dimensions in mm.

Knobs & Handles

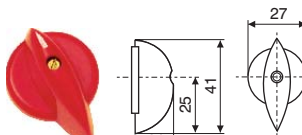
	Code	Type		
	TD	Tear Drop Knob		
	A	B	C	D
TD ¹	27	41	25	21
TD	36	52	31	25

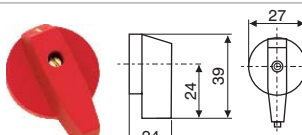
	Code	Type		
	FL	Flag Knob		
	A	B	C	D
FL ¹	27	39	24	24
FL	36	50	27	25

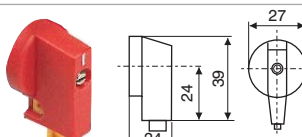
	Code	Type
	FP	Flag Knob Padlockable

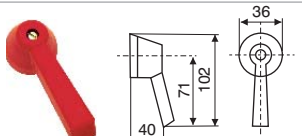
	Code	Type
	PG	Pistol Grip Handle

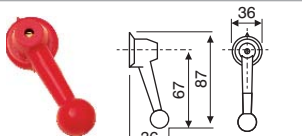
	Code	Type
	BG	Ball Grip Handle

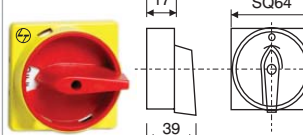
	Code	Type
	RD	Round Knob, Padlockable

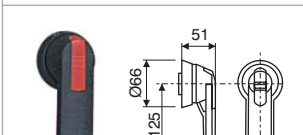
	Code	Type
	RH	Roll Handle, Padlockable

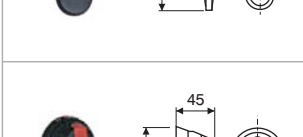
	Code	Type
	SH	Short Handle Padlockable

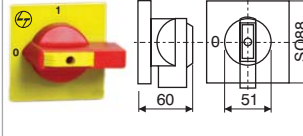
	Code	Type
	LH	Leech Handle Padlockable

LB Switches: Knob/Handle and Mounting Options

Mounting	LB116	LB120	LB225	LB232	LB240	LB263	LB4080	LB4100	LB4125
B03	FL ¹ , TD ¹	FL ¹ , TD ¹	FL, TD	FL, TD	FL, TD	FL, TD	-	-	-
B19	FP, FL ¹ , TD ¹	FP, FL ¹ , TD ¹	-	-	-	-	-	-	-
B40	FP	FP	-	-	-	-	-	-	-
B13	-	-	FL, PG, BG	FL, PG, BG	FL, PG, BG	FL, PG, BG	FL, PG, BG	FL, PG, BG	FL, PG, BG
B30	-	-	TD, FL-	TD, FL	TD, FL	TD, FL	FL	FL	FL
B33	-	-	RD	RD	RD	RD	RD	RD	RD
B63	-	-	TD, FL	TD, FL	TD, FL	TD, FL	FL	FL	FL
B23	-	-	TD, FL	TD, FL	TD, FL	TD, FL	FL, BG	FL, BG	FL, BG
MB34	FP	FP	SH, RD, LH, RH	SH, RD, LH, RH	SH, RD, LH, RH	SH, RD, LH, RH	SH, RD, LH, RH	SH, RD, LH, RH	SH, RD, LH, RH
MB42	FL ¹	FL ¹	BG, PG	BG, PG	BG, PG	BG, PG	BG, PG	BG, PG	BG, PG
AB31S, SB31S	RD	RD	RD	RD	RD	RD	-	-	-
B31SM	FP	FP	RD	RD	RD	RD	-	-	-
B31M, AB31M, SB31M	-	-	-	-	-	-	-	-	-
B31L, AB31L	-	-	-	-	-	-	RD, LH, BG, RH	RD, LH, BG, RH	RD, LH, BG, RH

The knobs/handles highlighted in red are standard, others indicate possible options.

LB Switches: Knob/Handle, Enclosure Mounting Options

Enclosure Mounting	B31SM	B31M	B31L	SB31S	SB31M	SB31L	AB31S	AB31M	AB31L
Knob/Handle	RD, FL, FP	RD	RD, LH	RD, BG, PG	RD, LH, BG, PG	LH, BG, PG, RD	RD, FL, FP	RD, LH, BG, PG	RD, LH, BG, PG

The knobs/handles highlighted in red are standard, others indicate possible options.

All dimensions in mm.

Switching Programme

Code : 31153 3 Pole Changeover

	R	Y	B	R	Y	B
I	X	X	X			
O						
II				X	X	X

Code : 31154 4 Pole Changeover

	R	Y	B	N	R	Y	B	N
I	X	X	X	X				
O								
II					X	X	X	X

Features

- 25 A - 125 A, 3 and 4 Pole, AC 23 duty
- Available with and without SS enclosure
- Different mounting options
- Excellent switching performance
- High short circuit capacity
- Door interlock and padlock available
- Provides adequate space for cable termination and very convenient for installation termination

B13

25 A-63 A, Front Mounting

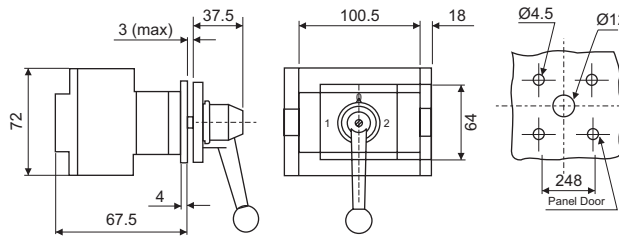

- 4 Hole front panel mounting
- Degree of protection : Front IP55

B21

25 A-63 A, Rear Mounting

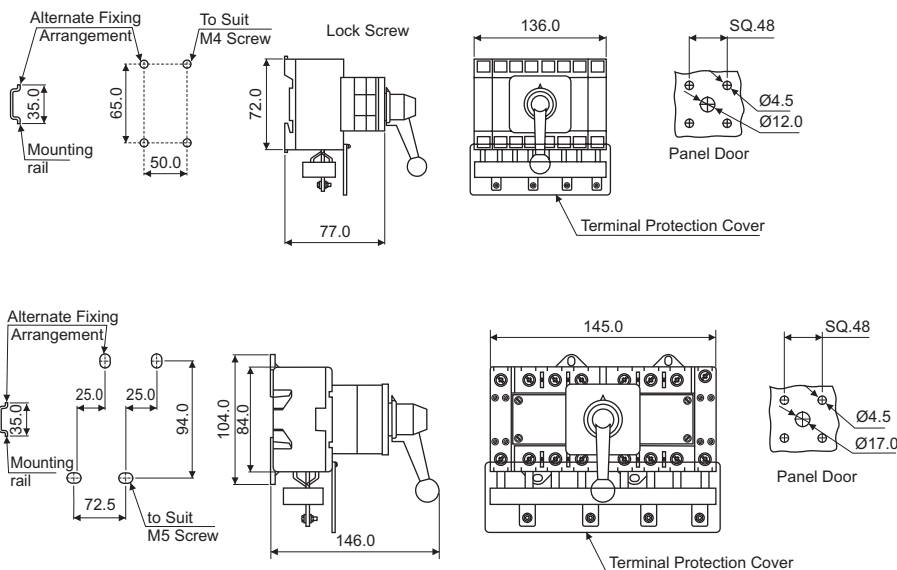

All dimensions in mm.

MB42



25 A-63 A, Rear Mounting

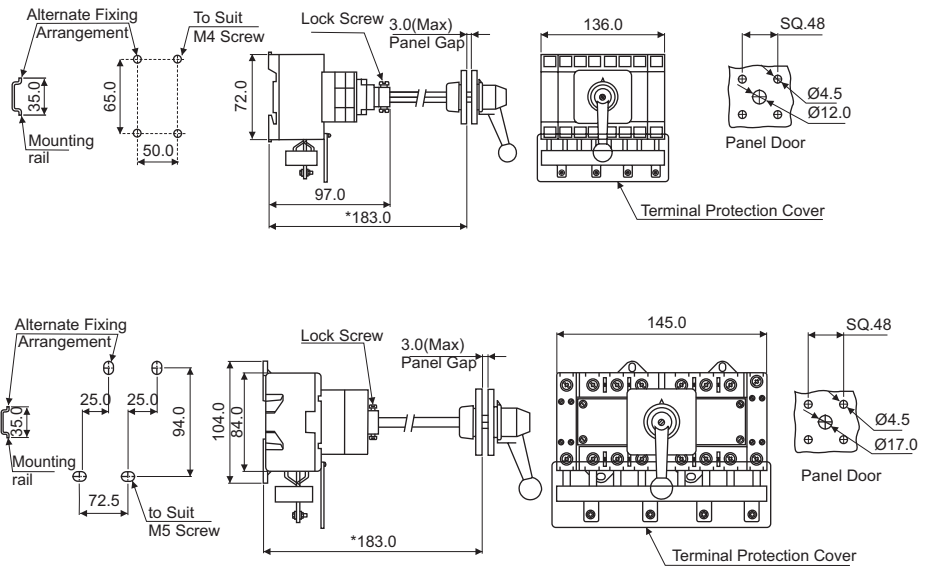

MB34



25 A-63 A, Rear Mounting

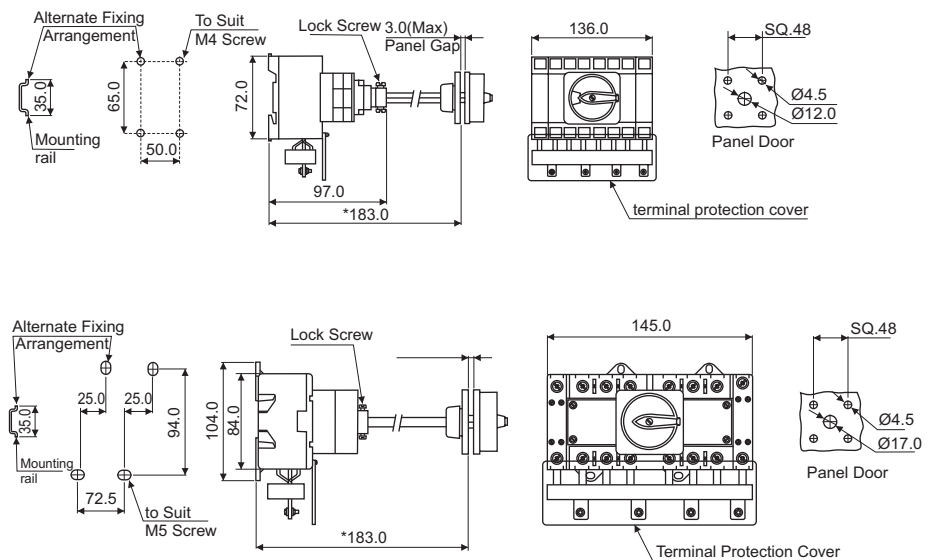

- 2 Hole rear mounting or snap mounting on DIN EN50022 rail (35 mm) and operable from the front (door) coupled with door mechanism
- Door interlock (door operable only in OFF position)
- Degree of protection : Front IP65
- Rigid metal shaft/switch assembly
- Switch with round padlocking device to prevent the switch from being made ON by unauthorized persons
- Max. 3 padlocks
- Adjustable mounting by cutting the metal shaft to appropriate length to suit panel height
- Specific length of shaft can be offered on request

All dimensions in mm.

Features

- 25 A - 125 A, 4 Pole, AC 23 duty
- Range available : 3 Pole Changeover - 31153, 3 Pole + Neutral Pole Changeover - 31154
- Powder coated steel enclosure with separate earthing or IP65, ABS enclosure having interlock to open the lid only in OFF position for safety
- Colour : Yellow front plate and Red ball grip handle

B31L



25 A-63 A

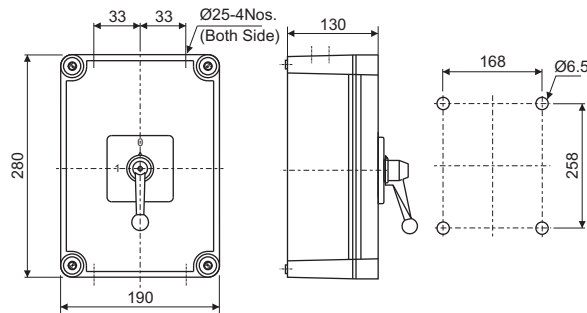

- Switch mounted in grey ABS / Polycarbonate optional enclosure with IP65 protection and interlock provided to open the lid in OFF position

SB31



25 A-63 A

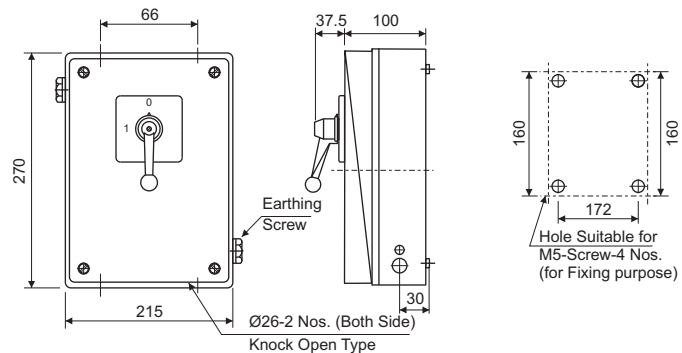

- Powder coated steel enclosure
- Interlock provided to remove cover only in OFF position for safety
- Separate earthing provided
- Colour : Yellow front plate and Red ball grip handle / grey front plate and Black ball grip handle

All dimensions in mm.

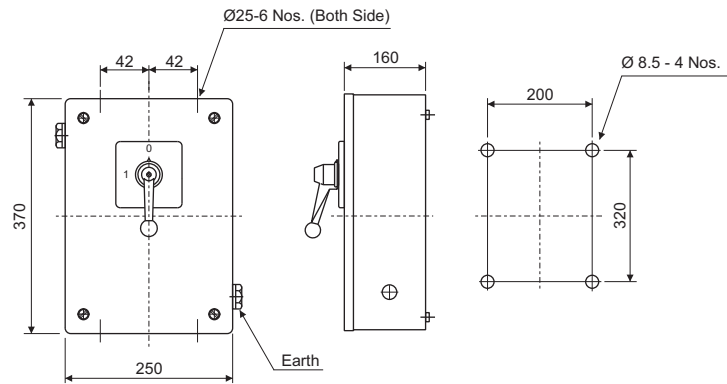
SB31XL**80 A-125 A**

- Powder coated steel enclosure
- Separate earthing provided
- Interlock provided to remove cover only in OFF position for safety
- Colour : Yellow front plate and Red ball grip handle / grey front plate and Black ball grip handle

Changeover Switches: Knob/Handle and Mounting Options

Mounting	LB225	LB232	LB240	LB263	LB4080	LB4100	LB4125
B13	PG, BG	PG, BG	PG, BG	PG, BG	-	-	-
MB34	RD	RD	RD	RD	RD	RD	RD
MB42	PG, BG	PG, BG	PG, BG	PG, BG	PG, BG	PG, BG	PG, BG
B21	BG, PG	BG, PG	BG, PG	BG, PG	PG, BG	BG, PG	BG, PG
SB31	BG, PG	BG, PG	BG, PG	BG, PG	-	-	-
SB31XL	-	-	-	-	BG, PG	BG, PG	BG, PG
B31L	RD, BG	RD, BG	RD, BG, PG	RD, BG, PG	-	-	-

All dimensions in mm.

Load Break and Changeover Switches

LB Load Break Switch	XXXX Switch Rating	XXXXXX Programme Code	XXXXXX Mounting Options	XX Knob Options	XX Colour
------------------------------------	-------------------------------	-------------------------------	---------------------------------	-------------------------	-------------------

Example

- LB Switches, 25 A, 3P, 9 O'clock, 4 hole front mounting, yellow front plate, red tear drop knob
LB 225 31309 B13 TD YR
- LB Switches, 63 A, 3P, 9 O'clock, 4 hole front mounting, with metal shaft, yellow front plate, red round knob
LB 263 31309 Mb34 RD YR
- LB Switches 40 A, 3P, 12 O'clock OFF in B31SM enclosure, grey front plate, black round knob
LB 240 31300 B31SM RD GB
- LB Changeover Switch, 63 A, 3P, metal enclosure with interlock, yellow front plate, red ball grip handle
LB 263 31153 SB31 BG YR

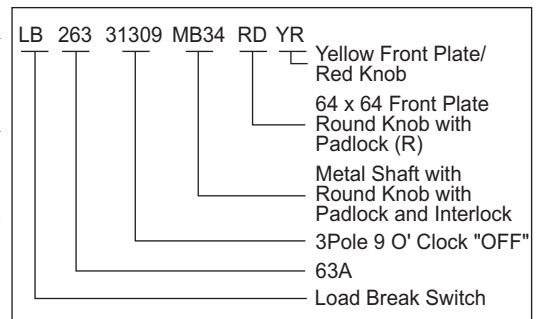

Accessories

X F-Front Mounting	XX MC-Main Module	XXX 20 - 16 A to 20 A 32 - 25 A to 32 A 63 - 40 A to 63 A 80 - 80 A 125 - 100 A, 125 A & 80 A
R-Rear Mounting	NC-Neutral Module	
	AC-Auxiliary Module	

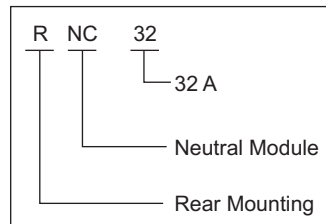

Product improvement is a continuous process. Hence, data given in this catalogue is subject to change without intimation. Please a certain Product Certification and Listing.



Wires & Cables



L&T House Wires are made up electrolytic grade, bright, plain annealed copper conductor, as per **IS : 8130 -1984**. These wires are suitable for all Commercial & Domestic wiring applications.

For additional safety, the insulation is of Flame Retardant - **FR PVC** compound. It has high oxygen and temperature index. These properties restrict propagation of flame and wires do not catch fire up to 250 degree centigrade at ambient oxygen level.

L&T House Wires are twin coated for superior insulation. The House Wires have uniform diameter and are available in standard lengths of 90 meter and 180 meter coils.

Single core, twin insulated wires in voltage grade 1100 V, conforming to IS : 694-1990 with additional FR properties.

Range - 0.75 Sq.mm to 16 Sq.mm

Nominal area of conductor	Number/Nom. Dia of wire	Thickness of insulation (Nom)	Approx. overall Diameter	Current carrying capacity* 2 cables, single phase		Max Resistance per km at 20°C
				In conduit/ Trunking	Unenclosed-clipped directly to surface or on cable tray	
Sq. mm	mm	mm	mm	Amp.	Amp.	Ohms
1.0	# 14/.3	0.7	2.8	11	12	18.10
1.5	# 22/.3	0.7	3.1	14	16	12.10
2.5	# 36/.3	0.8	3.8	19	22	7.41
4.0	\$ 56/.3	0.8	4.4	26	29	4.95
6.0	\$ 84/.3	0.8	5.0	31	37	3.30

Above data is indicative. L&T will not be liable for damage arising out of incorrect applications.

Standard Colour : Red, Yellow, Blue, Green, Black. * As per IS: 3961 (Part V) -1968.

As per Conductor Class 2 of IS : 8130 - 1984. \$ As per Conductor Class 5 of IS : 8130 - 1984.

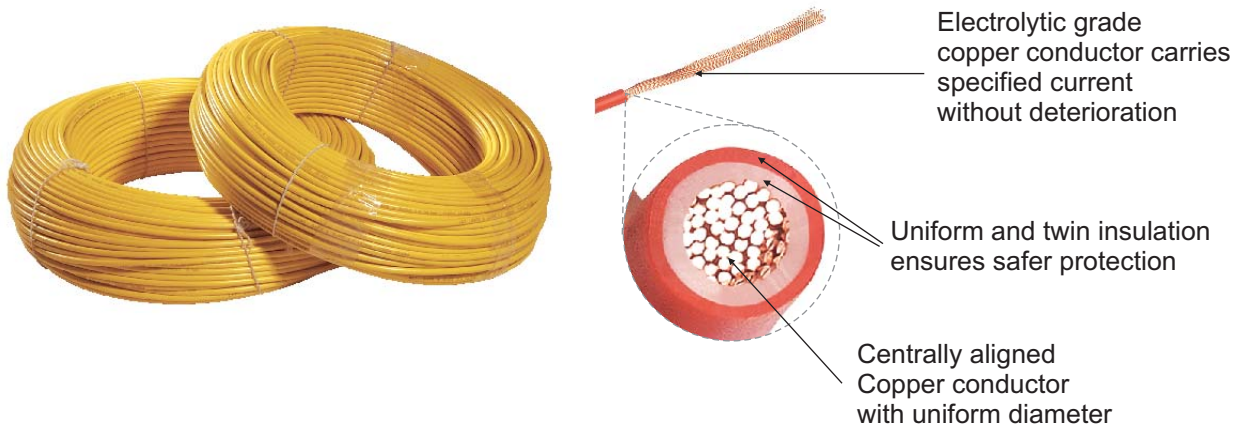

L&T Flame Retardant Low Smoke (FRLS) wire - These wires are made of special insulation material with higher oxygen and temperature indices and lower smoke density rating and acid gas generation. This insulation retards flame propagation and generates low smoke under fire condition.

Range - 1 Sq.mm to 16 Sq.mm.

L&T Zero Halogen Flame Retardant (ZHFR) wire - The insulation is free from halogen, thus preventing emission of corrosive gases under conditions of fire. These wires are primarily used where critical control supply is essential during fire like - lifts, fire alarms, hospitals etc.

Oxygen Index is used as a measure of flame retardant property of the insulating material. The oxygen index indicates percentage of oxygen required for supporting combustion of insulating material at room temperature. Higher oxygen index is desirable.

Temperature Index indicates the temperature at which normal oxygen content of 21% in air will support combustion of insulating material. Higher temperature index is better.

Smoke Density indicates the loss of light transmission from insulation material under fire. Lower the smoke density, the better is the visibility & efficacy of fire fighting operations.

Acid Gas Generation indicates the amount of hydrochloric acid gas evolved from insulation of cable under fire. lower acid gas generation is desirable.

Characteristics	Standard	Typical Value
Oxygen index	ASTM-D 2863	More than 29%
Temperature index	ASTM-D 2863	More than 250°C
Smoke density rating	ASTM-D 2843	Less than 60%
Acid gas generation	IEC 754-1	Less than 20%

L&T Flexible wires are made of bright, plain multi-stranded annealed copper conductor, as per Class 5 of **IS : 8130 - 1984** with PVC insulation. These wires are used for all industrial wiring applications and are available in single and multicore in standard length of 100 meter.

Single unsheathed cable (Flexible) voltage grade 1100 V, conforming to IS : 694-1990

Range - 0.5 Sq.mm to 240 Sq.mm

Nominal area of conductor	Number/ Nom. Dia of wire	Thickness of insulation (Nom)	Approx. overall Diameter	Current carrying Capacity as per IS : 3961	Max Resistance per km at 20°C
Sq. mm	mm	mm	mm	Amp.	Ohms
0.5	16/.2	0.6	2.20	04	39.00
0.75	24/.2	0.6	2.40	07	26.00
1.0	32/.2	0.6	2.60	11	19.50
1.5	30/.25	0.6	2.90	14	13.30
2.5	50/.25	0.7	3.50	19	7.98
4.0	56/.3	0.8	4.30	26	4.95
6.0	84/.3	0.8	4.80	31	3.30
10	80/.3	1.0	6.10	42	1.91
16	126/.4	1.0	7.00	57	1.21
25	196/.4	1.2	8.70	71	0.78
35	276/.4	1.2	10.00	91	0.55
50	396/.4	1.4	12.00	120	0.38
70.0	360/.5	1.6	14.30	160	0.27

Above data is indicative. L&T will not be liable for damage arising out of incorrect applications.

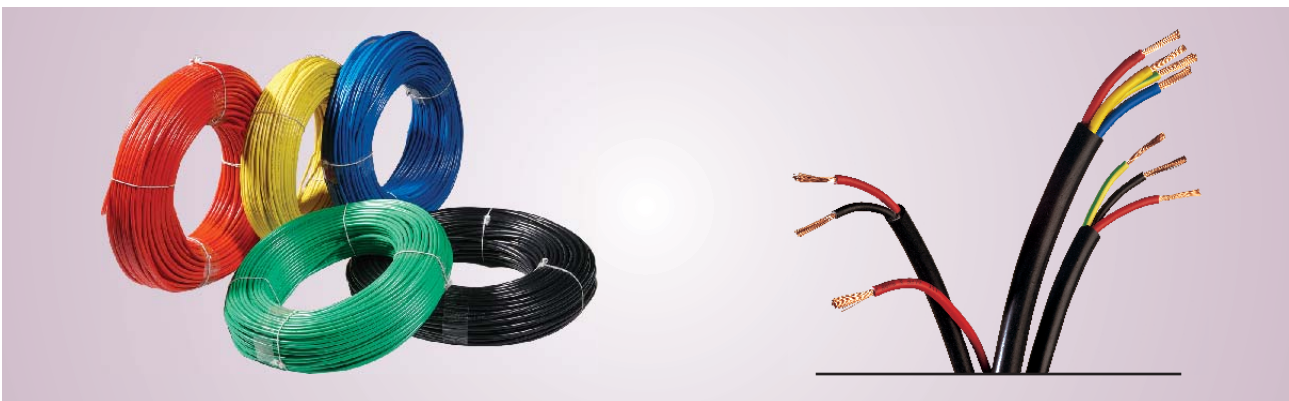

Core Colours :

- **2 Cores** - Red, Black
- **3 Cores** - Red, Black, Yellow / Green
- **4 Cores** - Red, Yellow, Blue, Yellow / Green

Sheath Color : Black

Agriculture Submersible Flat Cable

L&T agriculture submersible Flat cables are made of bright, plain multi-strand annealed copper conductor, as per class 5 of IS : 8130 : 1984. These cables are used for Agricultural submersible motor applications and are available in 3 core - 500 meter & 1000 meter drums.

Voltage Grade 1.1 kV (1100 V) conforming to IS : 694 : 1990.

Nominal Area of Conductor (Sq. mm)	No. of Conductor/ Nominal Dia of Wire (mm)	Thicknesses of Insulation (Nominal) (mm)	Nominal Thickness of Sheath (mm)	Max. Overall Diameter (mm)		Current Carrying Capacity as Per IS: 3961 (Amp.)	Max. Resistance Per Km at 20 °C (Ohms)
				W	B		
1.0	14/0.3	0.60	0.90	9.80	4.60	11	18.10
1.5	22/0.3	0.60	0.90	10.70	5.20	14	12.10
2.5	36/0.3	0.70	1.00	12.90	5.80	19	7.41
4.0	56/0.3	0.80	1.10	15.00	6.80	26	4.95
6.0	84/0.3	0.80	1.20	17.50	7.50	31	3.30
10.0	80/0.4	1.00	1.20	21.40	8.80	45	1.91

L&T XLPE Agricultural Flat Cables - These wires are made of cross-linked polyethylene material with high continuous conductor temperature - 90°C and high intermittent overloading - 130°C. Since it has better corrosion resistance, it is suitable for alkaline hard water areas.

Flat Cable Selection Chart

Submersible Pumpset Cable Selection Chart for 415 V - Three Phase - 50 Hz

Length (m) \ HP	10	20	30	40	50	60	70	80	90	100	120	140	160	180	200	250	300	350	400	450	500
3	1.5	1.5	1.5	1.5	1.5	1.5	1.5	1.5	1.5	1.5	1.5	2.5	2.5	2.5	2.5	4	4	4	6	6	6
4	1.5	1.5	1.5	1.5	1.5	1.5	1.5	1.5	1.5	1.5	2.5	2.5	2.5	4	4	4	6	6	6	10	10
5	1.5	1.5	1.5	1.5	1.5	1.5	1.5	1.5	2.5	2.5	2.5	2.5	4	4	4	6	6	10	10	10	10
6	1.5	1.5	1.5	1.5	1.5	1.5	2.5	2.5	2.5	2.5	2.5	4	4	4	6	6	10	10	10	10	16
7.5S	2.5	2.5	2.5	2.5	2.5	2.5	2.5	2.5	4	4	4	4	4	6	6	10	10	10	16	16	16
7.5D	1.5	1.5	1.5	1.5	1.5	1.5	1.5	1.5	1.5	1.5	2.5	2.5	2.5	4	4	4	6	6	10	10	10
10	1.5	1.5	1.5	1.5	1.5	1.5	1.5	2.5	2.5	2.5	2.5	4	4	4	6	6	10	10	10	10	16
12.5	2.5	2.5	2.5	2.5	2.5	2.5	2.5	2.5	4	4	4	4	4	6	6	10	10	10	16	16	16
15	2.5	2.5	2.5	2.5	2.5	2.5	2.5	4	4	4	4	6	6	6	10	10	10	16	16	16	16
17.5	4	4	4	4	4	4	4	4	4	4	6	6	6	10	10	10	16	16	16	25	25
20	4	4	4	4	4	4	4	4	4	6	6	10	10	10	10	16	16	16	25	25	25
25	4	4	4	4	4	4	4	4	4	6	6	10	10	10	10	16	16	25	25	25	35
30	6	6	6	6	6	6	6	6	6	6	10	10	10	10	16	16	25	25	25	35	35
40	10	10	10	10	10	10	10	10	10	10	10	16	16	16	25	25	25	35	35	50	50
50	16	16	16	16	16	16	16	16	16	16	16	16	16	25	25	35	35	50	50	50	70

Submersible Pumpset Cable Selection Chart for 220 V - Single Phase - 50 Hz

0.5	1.5	1.5	1.5	1.5	1.5	1.5	1.5	1.5	1.5	1.5	2.5	2.5	2.5	4	4	4	6	6	6	10	10
0	1.5	1.5	1.5	1.5	1.5	1.5	2.5	2.5	2.5	2.5	4	4	4	6	6	6	10	10	10	16	16
1.5	1.5	1.5	1.5	2.5	2.5	2.5	4	4	4	6	6	10	10	10	10	16	16	16	25	25	25
2	1.5	1.5	2.5	2.5	4	4	4	6	6	6	10	10	10	16	16	16	25	25	25	35	35
3	1.5	1.5	2.5	2.5	4	4	6	6	6	10	10	10	16	16	16	16	25	25	25	35	35
4	1.5	2.5	2.5	4	4	6	6	10	10	10	10	16	16	16	16	16	25	25	35	35	35
5	2.5	2.5	4	4	6	6	10	10	10	10	16	16	16	25	25	25	35	35	50	50	50

Note: 1. HP 7.5 D and above are STAR/DELTA motors
2. For STAR DELTA Starting reduce current by 1/3 for selecting suitable cable.
Conversion Table:
1 m = 3.28 ft.
1 ft = 0.305 m

Single Phase:
For other voltages the cable size is to be selected as follows:-
Calculated length = (220 + Volt) x actual length
Example: for a 3 HP 460 Volt motor and 100 meters actual cable length, calculated length = (220 + 460) x 100 = 48 m. The size of the cable to be selected for 48 m from the chart is 4 mm².

Three Phase:
For other voltages the cable size is to be selected as follows:-
Calculated length = (415 + Volt) x actual length.
Example: For a 20 HP motor at 350 Volt and 90 metres actual cable length, calculated length = (415 + 350) x 90 = 107m the size of the cable to be selected for 107 m from the chart is 6 mm².

Selection chart for Typical Domestic Loads*

Sr. No.	Items	Load / Wattage	MCB rating	Wire size Sq. mm
01	Fan	60 W	-	1
02	Lamp, Tubelight	40 W	-	1
03	Room Heater	200 W	1 A	1.5
04	Water Heater			
	8 ltrs	1200 - 2000 W	10 A	2.5
	15 ltrs	3000 - 4000 W	20 A	4
	60 ltrs	4000 - 6000 W	32 A	6
05	Immersion Heater	1000 W	6 A	1.5
06	Hot Plate - single	1000 W	6 A	1.5
07	Iron - non automatic	500 W	3 A	1.5
		1000 W	6 A	1.5
08	Mixer / Juicer	300 W	2 A	1.5
09	TV / VCR	200 W	1 A	1.5
10	Music system	200 W	1 A	1.5
11	Refrigerator			
	165 ltrs	400 W	3 A	1.5
	285 ltrs	600 W	4 A	1.5
	350	750 W	6 A	1.5
12	Toaster	500 W	3 A	1.5
13	Vacuum Cleaner	400 W	3 A	1.5
14	Washing Machine			
	without heater	300 - 1300 W	10 A	2.5
	with heater	5000 - 6300 W	32 A	6
15	Water Cooler	700 W	6 A	1.5
16	Desert Cooler	300 W	2 A	1.5
17	Oven	750 W	6 A	1.5
18	Electric Kettle	1500 W	7.5 A	1.5
19	Air Conditioner	1 ton	10 A	2.5
		1.5 ton	16 A	4
		2 ton	16 A	4
20	Hair Dryer	1000 W	7.5 A	1.5
21	Microwave	800 W	6 A	1.5

Formula for Calculations :

Incomer Rating : Single Phase = $\frac{\text{Total Load in Watts}}{230 \text{ volts}}$

Three Phase = $\frac{\text{Total Load in Watts}}{3 \times 230 \text{ volts}}$

Max. Short Circuit current as per Transformer kVA*

Transformer Rating kVA	Full Load Current at 415 V A	Max. Short Circuit Current (kA)	
		4% impedance	5% impedance
25	35	0.875	0.7
40	56	1.4	1.1
63	88	2.2	1.8
100	139	3.5	2.8
125	174	4.4	3.5
160	223	5.6	4.5
200	278	7	5.6
250	348	8.7	7
315	438	11	8.8
400	560	14.2	11.3
500	695	17.4	13.9
630	876	21.9	17.5
800	1112	27.8	22.2
1000	1390	34.8	27.8
1250	1740	43.5	34.8
1600	2230	55.8	44.6
2000	2780	69.5	55.6
2500	3480	87	69.6

Derating of Wires*

Ambient Temp. °C	30	35	40	45	50
Rating factor	1.09	1.04	1	0.85	0.77

* Above data is indicative. L&T will not be liable for damage arising out of incorrect applications.

The above data is only for guidance and may vary for different manufacturers. The proper load of items should be checked for current requirement and appropriate Wire and MCB size should be accordingly chosen.

L&T Wire Range



FR House Wires

0.75 mm² to 16 mm²



Flexible Wires

0.5 mm² to 240 mm²



Flat Cables

1.0 mm² to 35 mm²



Cable Ducts

Features

- Manufactured from specially compounded high-impact rigid polyvinyl chloride
- Will not peel, chip or crack
- Resists oil, salt solution and fungus
- Nonflammable, warp-proof and non-brittle
- High dielectric strength and withstands temperature upto 60°C
- Unique cover locking design prevents popping up of wires while removing cover
- Elongated slots at the bottom allow flexible mounting
- Heavy & robust sections

Applications

- Facilitates systematic Wiring
- Enhances aesthetics and clarity
- Permits faster connections, addition and fault tracing of wires
- Avoids bunching and tapping
- Provides complete electrical insulation
- CE marked

Material Specification

- Material : High impact, self extinguishing, warp-proof rigid PVC
- Other materials such as chlorine free PPO is available on request

Colour

- Standard: Greenish grey for B type and light grey for A type
- Other colours: Black, Ivory, White, Blue and Green are available for large quantities

Mechanical Properties

- Tensile strength - 390 kg/cm² IZOD
- Impact strength - 7 kg.cm/cm

Electrical Properties

- Dielectric strength - 36 kV/mm
- Specific resistance - 6.1 x 10¹⁴

Thermal Properties

- Flammability - UL 94 VO

Slotting Styles (A & B Types)

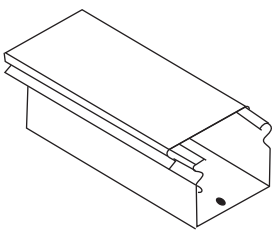

Unslotted
(US)

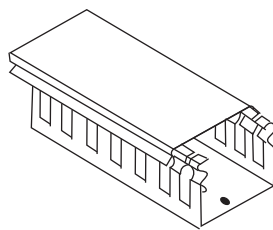

Standard Slotted
(S)

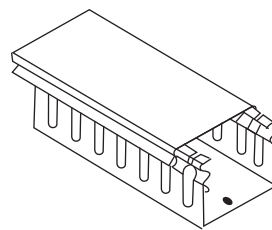

Straight Slotted
(L)

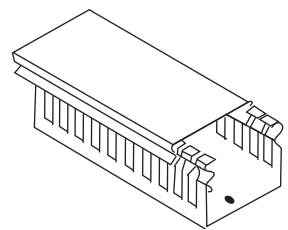

Thin Slotted
(T)

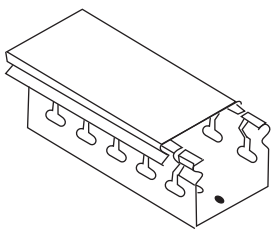

Horizontal Slotted
(H)

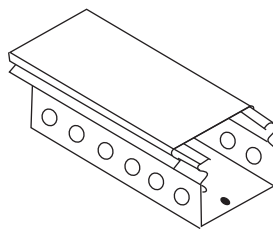

Circular Slotted
(C)

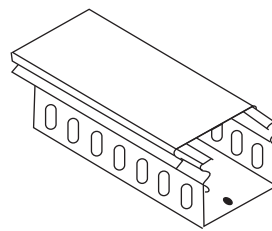

Oblong Slotted
(O)

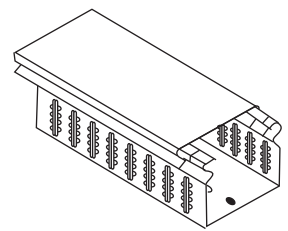

Multiple Slotted
(M)

B Type

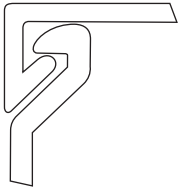

Non slip cover design of minimum encumbrance and maximum grip

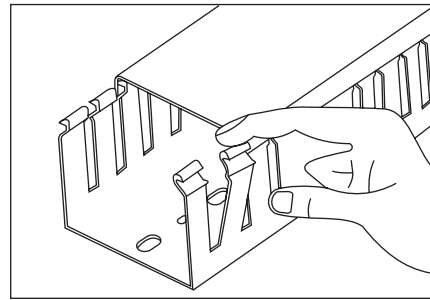
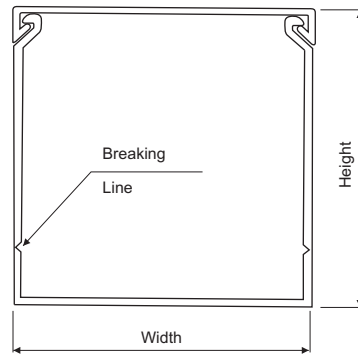

Snap-off side wall fingers permit enlarging slot for any size of wire or wire bundles. Requires no tools for cutting.

Channel with cover width x Height (mm)	Cable housing Capacity (numbers)			Standard Pack Channel with cover (in 1 mtrs)	Standard Pack Channel with cover (in 2 mtrs)	Available Slotting Style
	1.5 mm ² OD 3.18 mm (16 AWG)	2.5 mm ² OD 3.53 mm (14 AWG)	4 mm ² OD 4.01 mm (12 AWG)			
B25 x 30	37	30	23	100	36	S
B25 x 40	48	39	31	75	36	S, T
B25 x 60	72	57	45	50	18	S, T
B25 x 80	92	75	59	50	18	S, T
B25 x 100	126	105	81	50	18	S
B30 x 20	31	25	20	100	36	US
B45 x 20	40	32	25	75	18	US
B40 x 40	81	65	51	50	18	S, T
B40 x 60	121	98	77	50	18	S, T
B40 x 80	160	130	102	50	18	S, T, O
B40 x 100	200	164	128	40	12	S, T
B50 x 100	135	195	152	40	8	S, T
B60 x 20	61	50	39	50	18	US
B60 x 40	123	99	78	50	12	S, T
B60 x 60	180	146	114	50	12	S, T
B60 x 80	246	199	156	40	12	S, T, O
B60 x 100	308	247	194	30	8	S, T
B72 x 64	234	190	149	32	18	S
B75 x 75	291	236	185	32	12	S
B75 x 100	394	333	251	24	8	S, T
B80 x 40	165	134	105	50	12	S, T
B80 x 60	251	203	159	40	12	S, T
B80 x 80	337	272	214	32	12	S, T, O
B80 x 100	416	332	248	25	8	S, T
B100 x 60	316	256	201	30	8	S, T
B100 x 80	425	344	270	24	8	S, T
B100 x 100	531	429	336	18	8	S, T
B120 x 80	499	405	318	18	4	S
B150 x 100	807	653	512	12	4	S, T
B150 x 150	1100	960	750	8	4	S, T

All dimensions in mm.

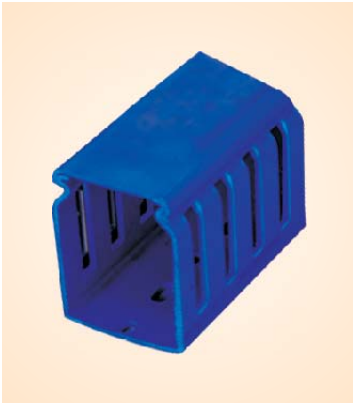

Cover Standard Pack	
Cover Code	Cover Standard Pack Total Length In mtrs
BC25	100
BC30	100
BC40	64
BC45	52
BC50	52
BC60	44
BC72	44
BC80	44
BC100	44
BC125	25
BC150	25

Slotting Style

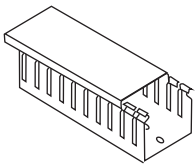

Standard Slot (S)

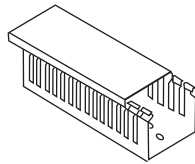

Thin Slot (T)

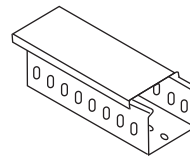

Oblong Slot (O)

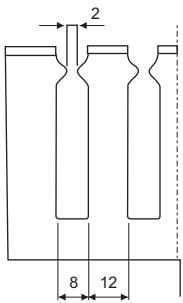

Standard Slot

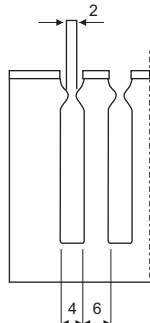

Thin Slot

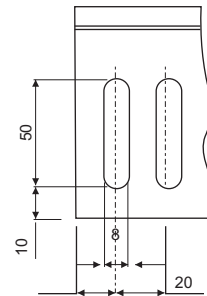

Oblong Slot

Bottom Slotting Style

Duct Width : 25 mm, 30 mm

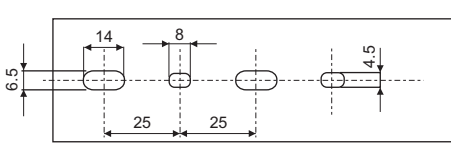

Duct Width : 40 mm, 50 mm, 60 mm, 72 mm, and 75 mm

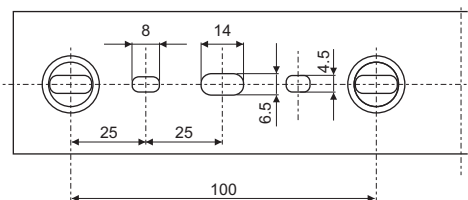

Duct Width : 150 mm

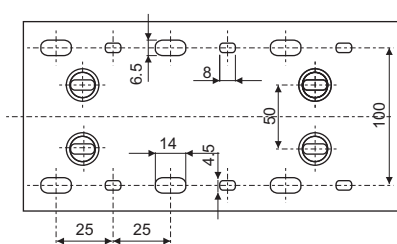

Duct Width : 80 mm, 100 mm and 120 mm

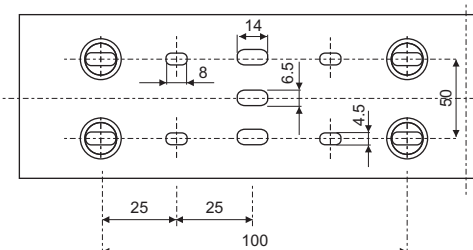

All dimensions in mm.

A Type

Specially designed profiles of duct and cover for fast and efficient locking.

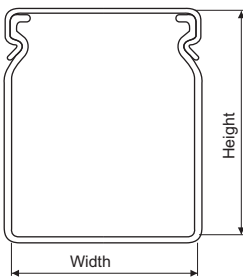

Channel with Cover Height X Width (mm)	Cable Housing Capacity (nos)			Available Slotting Styles	Standard Pack Channel with Cover	
	1.5 mm ² OD 3.53 mm (16 AWG)	2.5 mm ² OD 3.53 mm (14 AWG)	4 mm ² OD 4.01 mm (12 AWG)		1 mtrs	2 mtrs
	A15 x 15	11	9		7	H
A15 x 25	19	15	12	H	50	64
A25 x 25	31	25	20	S, O, T	50	48
A30 x 25	37	30	23	S, O, T	50	48
A40 x 30	59	48	37	S, T	30	48
A45 x 25	56	45	35	S, O, C, M, T, L	30	48
A45 x 30	67	54	42	S, O, C, M, T, L	25	32
A45 x 45	100	81	63	S, O, C, M, T, L	30	18
A45 x 60	134	108	84	S, O, C, M, T, L	25	24
A60 x 25	74	60	47	S, O, T	30	18
A60 x 45	134	108	84	S, O, T	30	18
A60 x 60	178	145	112	S, O, T	25	18
A60 x 120	356	289	224	S	8	4
A75 x 45	167	135	105	S, T, C	24	18
A75 x 75	278	226	175	S, T, C	16	8
A80 x 80	316	257	199	S, T	16	8
A100 x 100	495	401	311	S	6	4

Note: All sizes are available in unslotted (us) style.

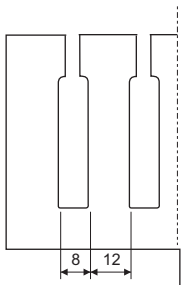

Standard Slot

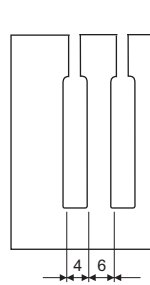

Thin Slot

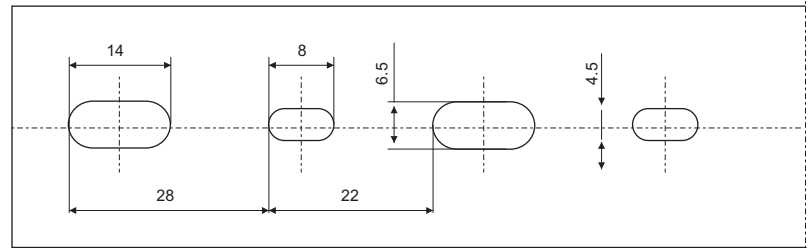

Bottom Mounting Slots for All Sizes

All dimensions in mm.

HFFR: (Halogen Free Fire Retardent Cable Ducts)







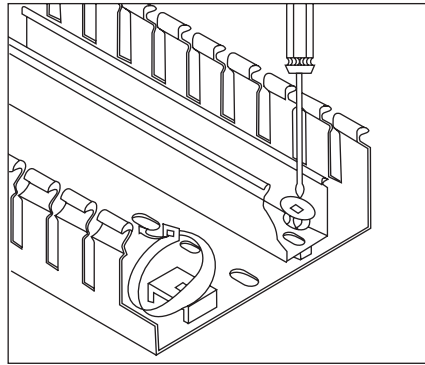
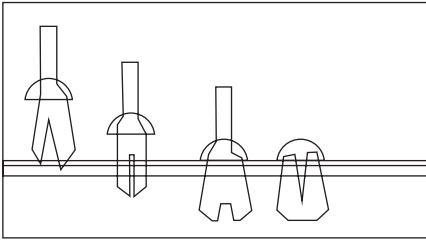

HFFR Cable ducts are made from specially formulated compound, which does not release significant amount of toxic gases or corrosive gases when ignited in a fire. These wiring ducts are free from halogens such as fluorine, chlorine, bromine, iodine, and/or astatine. These are tested and confirms to EN 50085 and IEC 60754-2 for. These have maximum application temperature (+90°C) than PVC ducts. Hence can be used in halogen free or high temperature indoor applications. It confirms to UL94 - V0 and 960°C Glow wire test as per IEC 60695-2-11.

Applications:

- Oil, Gas and Petrochemical facilities
- Railways, Ships and Metro rails
- Outdoor Panels, data centres and power generation facilities

Note: Applicable in all sizes on request.



Sr. Nos.	Part Name	Figure	Ordering Code	Standard Packing
1	Fixing Lug		BFL 1	100
2	Cable Tie Attachment		BCT 1	100
3	Nylon Fastener		BNF 6 (6 mm) BNF 4 (4 mm)	100 100
4	Wire Retainer I		BWRT (Thin)*	100
5	Wire Retainer II		BWRS (STD)	100
6	Name Plate		BNPS (STD) BNPT (Thin)	100
7	Mounting Clip I		BMC 1	100
8	Mounting Clip II		BMC 2	100

* Pls. specify size & slotting style while Ordering.

Ordering Procedure

Type	Size	Slotting	Total Length (in multiple of standard packs)
A	45 x 45	T	36 metres
B	60 x 60	S	48 metres

Product improvement is a continuous process. Hence data given in this catalogue is subject to change without intimation.

All dimensions in mm.



Timing Devices & Supply Monitors

Timers and supply monitoring devices find their use in a wide variety of applications in the industry. L&T's reliable Timing devices and Supply monitors from GIC over the past 3 decades have provided the best solutions to its customers.

GIC product range includes:

- Time switches
- Timers
- Supply monitoring devices (Voltage and Current)
- Digital hour meter / Digital counter

Time Switches are used for fixed time based daily / weekly applications. They are ideal for lighting applications and are also used to control air-conditioners / coolers, geysers, conveyers, pumps & exhaust fans etc.

Timers are used to control processing times in a wide range of applications which includes star to delta changeover operations in Motor control / Starter panels, elevators, conveyor belt sequences, air conditioning systems, warning light systems etc.

The supply monitors ensure reliable detection of phase parameters such as phase loss, phase sequence and phase unbalance in all three-phase networks. They find application in HVAC, welding machines, elevators and cranes, etc.

The Current Monitoring Relay provides monitoring and protection of loads against overload, underload, phase loss, phase asymmetry and phase sequence faults. Their applications include all motor and pump protection panels with single phase and three phase supply.

The Earth Leakage Relay monitors, detects and protects power systems from earth leakage faults with wide selectable range of 30mA to 30A. They are widely used in mines and in Gen sets.

Standards for Timing Devices & Supply Monitors

EMI/EMC:		
Harmonic current emissions	IEC 61000 - 3 - 2	Ed. 3.0 (2005 - 11) Class A
Voltage flicker & fluctuation	IEC 61000 - 3 - 3	Ed. 2.0 (2008 - 06) Class A
ESD	IEC 61000 - 4 - 2	Ed. 1.2 (2001 - 04) Level II
Radiated susceptibility	IEC 61000 - 4 - 3	Ed. 3.0 (2006 - 02) Level III
Electrical fast transients	IEC 61000 - 4 - 4	Ed. 2.0 (2004 - 07) Level IV
Surge	IEC 61000 - 4 - 5	Ed. 2.0 (2005 - 11) Level IV
Conducted susceptibility	IEC 61000 - 4 - 6	Ed. 2.2 (2006 - 05) Level III
Power frequency magnetic field	IEC 61000 - 4 - 8	Ed. 1.1 (2001 - 03)
Voltage dips and interruption (AC)	IEC 61000 - 4 - 11	Ed. 2.0 (2004 - 03) Class B
Conducted emission	CISPR 14 - 1	Ed. 5.0 (2005 - 11) Class B
Radiated emission	CISPR 14 - 1	Ed. 5.0 (2005 - 11) Class B
Safety:		
Test voltage between input and output	IEC 60947 - 5 - 1	Ed. 3.0 (2003 - 11) 2 kV
Impulse voltage between input and output	IEC 60947 - 5 - 1	Ed. 3.0 (2003 - 11) Level IV
Single fault	IEC 61010 - 1	Ed. 2.0 (2001 - 02)
Insulation resistance	UL508	Ed. 17 (1999 - 01) > 2000 M
Leakage current	UL508	Ed. 17 (1999 - 01) < 3.5 mA
Environmental testing:		
Cold heat	IEC 60068 - 2 - 1	Ed. 6.0 (2007 - 03)
Dry heat	IEC 60068 - 2 - 2	Ed. 5.0 (2007 - 07)
Vibration	IEC 60068 - 2 - 6	Ed. 7.0 (2007 - 12) 5 g
Repetitive shock	IEC 60068 - 2 - 27	Ed. 4.0 (2008 - 02) 40 g, 6 ms
Non-repetitive shock	IEC 60068 - 2 - 27	Ed. 4.0 (2008 - 02) 30 g, 15 ms

Analog Time Switch

Type FM/1

- Modular construction
- Power reserve upto 150 hrs
- Inbuilt over-ride facility
- High switching capacity
- Analog and digital versions
- Tamper proof sealing
- 1 set of changeover, 240 V AC, 16 A (resistive)
- Enclosure IP55 with gland plate and locking arrangement



Description	Cat. No.	
	Flush Mounting	Base/DIN rail Mounting
One daily dial 240 V AC - QT	J648F1	J648B1
One weekly dial 240 V AC - QW	J848F1	J848B1
One daily dial 110 V AC - QT	J638F1	J638B1
One weekly dial 110 V AC - QW	J838F1	J838B1
Digital 240 V AC	D847F2	D847B2

Connection Diagrams

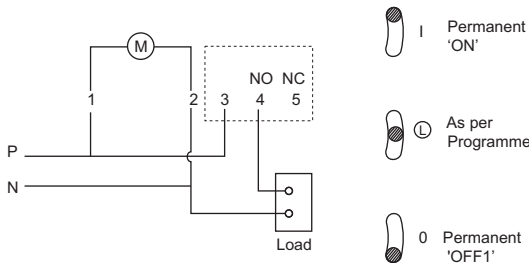

Overall Dimensions

Base/DIN Mounting

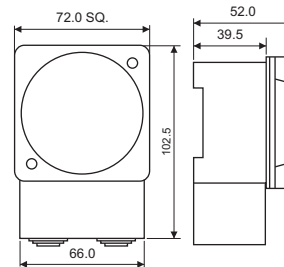

Flush Mounting

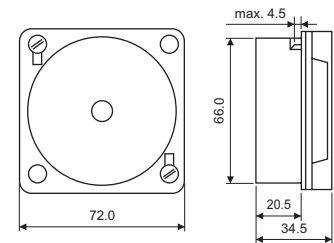

Time Switches		FM1 / QT	FM1 / Digi 20
Supply voltage & frequency		240 V AC, 50/60 Hz	240 V AC, 50/60 Hz
Power consumption		2 VA	4.4 VA
Accuracy		±1.5 Sec / day at 20°C	±1 Sec / day at 20°C
Switching contact		1 C/O contact - AgCdO	1 C/O contact - AgCdO
Contact rating	Resistive	16 A @ 250 V AC	16 A @ 250 V AC
	Inductive (cosφ = 0.6)	8 A @ 250 V AC	4 A @ 250 V AC
	Incandescent lamp	1350 W	1350 W
Shortest switching time	Daily	15 min	1 min
	Weekly	2 hrs	1 min
Power reserve		150 hrs	10 years from factory @ 20°C
Memory locations		NA	20
Ambient temperature		-20°C to 55°C	-20°C to 55°C
Manual over-ride		Provided	Provided
Mounting		Flush, Base/DIN	Flush, Base/DIN
Weight (unpacked)		185 gms (approx)	185 gms (approx)

Crono & Pulse

- Precise time programming for daily/weekly/pulse applications
- 25 ON/OFF programs
- Weekend exclusion & weekly OFF programming
- LED Indication for relay status
- 12/24 hour display format
- 6 years battery reserve
- Simple reset & manual override
- Settable DST & keypad lock feature



Description	Cat. No.
Crono time switch, 110 - 240 V AC (50/60 Hz), 1 C/O (SPDT), 25 ON / OFF	67DDT0
Crono time switch, 24 V DC, 1 C/O (SPDT), 25 ON / OFF	6GHDT0
Crono time switch, 12 V DC, 1 C/O (SPDT), 25 ON / OFF	69HDT0
Pulse time switch, 110 - 240 V AC (50/60 Hz), 1 C/O (SPDT), 16 Pulse	67DDT9

Connection Diagrams

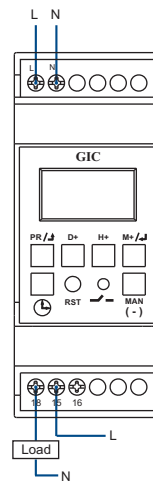

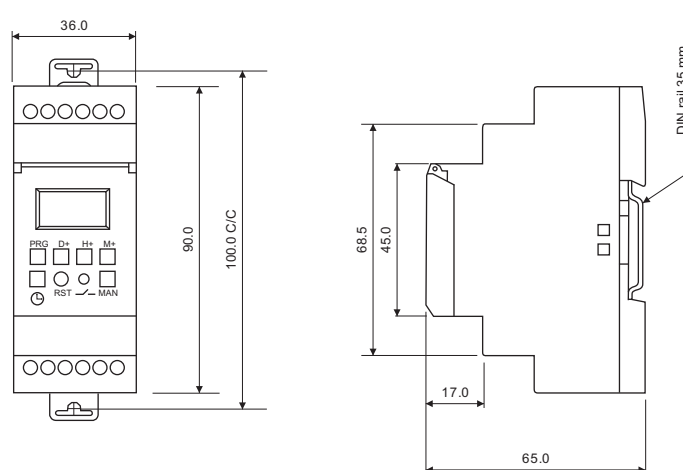

67DDT0, 67DDT9, 6GHDT0, 69HDT0

Overall Dimensions



Crono & Pulse

Cat. No.	Crono			Pulse
	67DDT0	6GHDT0	69HDT0	67DDT9
Supply voltage (⚡)	110 to 240 V AC (-20% to +10%) 50/60 Hz	24 V DC	12 V DC	
Power consumption (Max.)	6 VA			
Battery backup	Approx 6 years running reserve			
LED indication	Red LED for Relay status			
Clock format	Either AM / PM (12 h) or 24 h clock			
Reset	Programs and clock are reset to default			
Number of memory locations	25 ON / OFF programs			16 ON programs
Number of operating modes	5 Modes			3 Modes
Contact arrangement	1 C/O (SPDT)			
Contact rating:	Resistive	16 A (NO) and 5 A (NC) @ 240 V AC / 24 V DC		
	Incandescent lamps	1000 W		
	Inductive load (Cos Ø = 0.6)	6 A @ 250 V AC		
Minimum switching load	40 mA at 24 V DC			
Mechanical life	50 x 10 ³			
Electrical life	30,000 cycles @ rated load			
Minimum switching time	1 min			1 second
Utilization category:	AC-15	Ue Rated voltage (V): 120/240, Ie Rated current (A): 3.0/1.5		
	DC-13	Ue Rated voltage (V): 24/125/250, Ie Rated current (A): 2.0/0.22/0.1		
Clock accuracy	±2 s / day max. over the operating temperature range			
Operating temperature range	-10°C to +55°C			
Humidity (Non-condensing)	95% Rh			
Maximum operating altitude	2000 m			
Degree of protection	IP20 for terminals, IP40 for enclosure			
Mounting	Base/DIN rail			
Enclosure	Flame retardant UL 94-V0			
Weight (unpacked)	110 gms (approx)			
Certification	  			

Astro Mini

- Astronomical time switch in 35 mm size
- Latitude / longitude precise to the minute with time zone
- Sunrise / sunset or twilight rise / set trigger modes
- DST, Offset, OFF hours, weekly OFF features
- 12/24 hour display format
- 6 years battery reserve
- Easy manual override
- Ideal for outdoor & street lighting application



Description	Cat. No.
Astro Mini, 110 - 240 V AC 1 Phase 2 Wire (50/60 Hz), 1 C/O (SPDT)	T2DDT7

Connection Diagrams

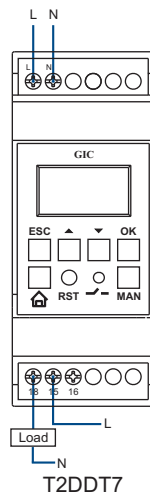

Overall Dimensions

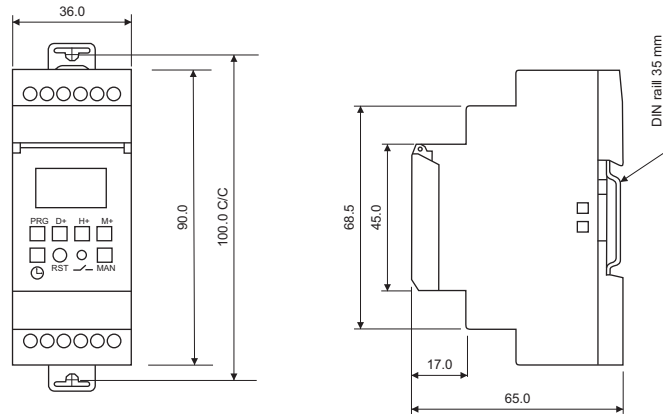

Operational Modes

Trigger Modes: The output can be programmed to switch ON/OFF at either sunrise / sunset or Twilight rise / set. The time settings of all outputs can either be based on sunrise / sunset or twilight. The trigger mode SRISE / SET will provide the reference time from sunrise / sunset, while the trigger mode TWILIGHT will provide the reference time from start / end of twilight.



OFFSET: The OFFSET feature is used to switch ON the output before or after sunset or switch OFF the output before or after sunrise. It may be necessary to have an output action before or after some time of sunrise / sunset. This OFFSET from sunrise / sunset can be achieved using OFFSET feature of the ASTRO Mini that allows OFFSET upto 99 minutes.

OFF-Hours: The OFF-Hours feature is used to switch OFF the output for a particular time period on daily basis. For example, OFF-Hours from 23:00 to 02:00 will switch the output OFF for three hours everyday.

Weekly OFF: The Weekly OFF feature is used to switch off the outputs during weekends or weekly off or weekly off days. This feature allows to define the Weekly off days including the start and end time. However ASTRO allows to program weekly off day (s) and related begin / end time. This feature offers energy savings by switching an output off on weekly-off day (s).

Day-light Saving Time (DST): DST is the period in which clocks in certain countries are set one hour or more ahead of standard time to effectively use natural daylight. ASTRO provides settings to easily define DST start and end months and DST offset time to effectively manage the shifting of clock year after year without any manual intervention.

Astro Mini

Cat. No.		T2DDT7
Supply voltage (≠)		110 to 240 V AC (-20% to +10%) 50/60 Hz
Power consumption (Max.)		6 VA
Battery backup		Approx 6 years running reserve
LED indication		Red LED for Relay Status
Clock format		Either AM / PM 12 h or 24 h Clock
Reset		Programs and clock are reset to default
Modes		Auto ON, Auto OFF, Auto
Programming		Based on:
		1) Latitude / Longitude precision to the minute, with time zone
		2) Option for both sunrise / set & twilight rise / set
		3) DST feature - 1 hour (with indication on the screen)
		4) Weekly OFF
		5) Offset facility
Contact arrangement		1 C/O (SPDT)
Contact rating	Resistive	16 A (NO) and 5 A (NC) @ 240 V AC / 24 V DC
	Incandescent lamps	1000 W
	Inductive load (Cos Ø = 0.6)	6 A @ 250 V AC
Minimum switching load		40 mA at 24 V DC
Mechanical life		50 x 10 ³
Electrical life		30,000 cycles @ rated load
Minimum switching time		1 min
Utilization category	AC-15	Ue Rated voltage (V): 120 / 240, Ie Rated current (A): 3.0 / 1.5
	DC-13	Ue Rated voltage (V): 24 / 125 / 250, Ie Rated current (A): 2.0 / 0.22 / 0.1
Clock accuracy		±1s / day @ 25°C
Operating temperature range		-10°C to +55°C
Humidity (Non-condensing)		95% Rh
Maximum operating altitude		2000 m
Degree of protection		IP20 for terminals, IP40 for enclosure
Mounting		Base/DIN rail
Enclosure		Flame retardant UL 94-V0
Weight (unpacked)		110 gms (approx)
Certification		 

Astro

- Sunrise / sunset or twilight trigger mode
- ON / OFF / Pulse
- Midnight off hours selectable
- OFF-hours feature to alternate channel on alternate days
- Turn off outputs on weekly off-days in offices
- Automatic offset change for specified period
- Easy, fast and single key press manual override
- Designed for lighting applications
- Modbus communication for 3 phase version



	Description	Cat. No.
	Astro time switch, 110-240 V AC (50-60 Hz), 1 Phase 2 Wire, 2 NO (SPST)	T2DDT0
	Astro time switch, 110-240 V AC (50-60 Hz), 3 Phase 4 Wire (P-N), 3 NO (SPST)	T3DDT0
Accessories for Astro	Software on PC	TGDDT6
	Serial interface cable	GFDNN2S
	Memory card	GFDNN3M
	USB interface cable	GFDNN1

Connection Diagrams

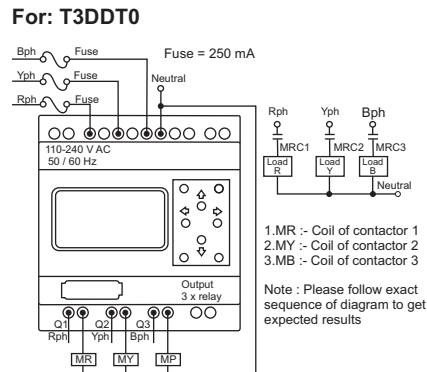
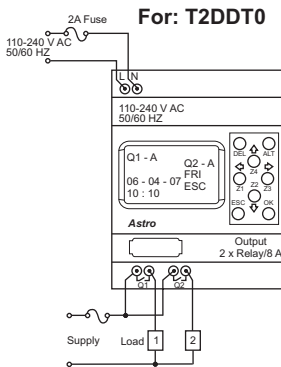

Overall Dimensions

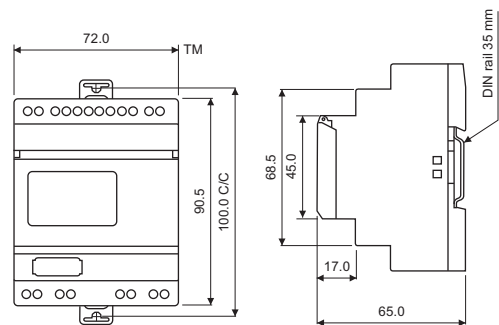

Additional Modes of Operation

Astro has following modes of operations in addition to Astro Mini's operational modes.

Operating Mode: ASTRO has three operating mode ON, OFF, and PULSE. An 'ON' or 'OFF' op-mode causes an output to be turned 'ON' or 'OFF' with respect to sunrise / sunset. A PULSE op-mode is used to have an output ON for few seconds from a particular time.



Season Mode: During rainy season or in cloudy atmosphere, sunlight may be insufficient. Hence different time offset needs be programmed to control light switching. User can program period of such season and the related time-offset. This feature helps switch lights early with respect to sun rise/set and automatically move back to original settings after the season period.

OFFSET: It may be necessary to have an output action before or after some time of sunrise / sunset. This offset from sunrise / sunset can be achieved using OFFSET feature of the ASTRO. It allows offset upto $\pm 10:59$ hrs.

Alternate Mode: In this mode, the off-hours feature is applied to alternate output on alternate days. This mode is useful to save energy due to off-hours feature and is useful to maximize load's life due to alternate action.

UV/OV Mode: When Under / Over Voltage condition prevails, load can be tripped off thereby protecting load from damage due to extreme voltage irregularities. Users can set Under & Over Voltage as per their requirement.

Astro

Cat. No.		T2DDT0	T3DDT0
Supply voltage (Un)		110 - 240 V AC (-20% to +15%), 50/60 Hz (1 Phase, 2 Wire)	110 - 240 V AC (-20% to +15%), 50/60 Hz (3 Phase, 4 Wire)
Power consumption		8 VA @ 300 V AC	
Operating temperature		-10°C to +50°C	
Switching contacts		2 NO	3 NO
Contact rating		8 A (Res.) @ 240 V AC and 5A (Res.) @ 30 V DC	
Power reserve (For clock only)		1000 h	
Utilization category	AC-15	Ue Rated voltage (V): 120/240, Ie Rated current (A): 3.0/1.5	
	DC-13	Ue Rated voltage (V): 24/125/250, Ie Rated current (A): 2.0/0.22/0.1	
Shortest switching time (Daily)		1 Minute	
Clock deviation (max)		±1 second per day over the operating temperature range	
Geographical Co-ordinates		Resolution 1°1'	
DST		Programmable	
Manual override		Provided use keys on keypad	
Display		Backlit LC text display for diagnostic view	
Degree of protection		IP20 for terminals, IP40 for enclosure	
Mechanical life		10 million	
Electrical life		0.1 million	
Under/Over voltage (UV/OV) trip value		Not applicable	Settable UV: 0-220 V and OV: 130-330 V
Trip time for UV/OV		Not applicable	5-16 seconds
Recovery time		Not applicable	1-4 seconds
Mounting		Base/DIN rail	
Dimension (in mm)		72 x 90 x 67	
Weight (unpacked)		190 gms (approx)	208 gms (approx)
Certification		  	

Astro using GSM Technology

- Energy meter functionality. Parameter like load current, supply voltage, power, energy can be known remotely
- ASTRO parameters set remotely using SMS queries. i.e. output mode, offset hrs etc, UV, OV settings
- Relay output can be override remotely using SMS query
- With the help of 'Auto Error Code Update' following onsite errors can be known remotely during output event
 - Under voltage
 - Over voltage
 - Over current
 - Output actuator short
 - Load open





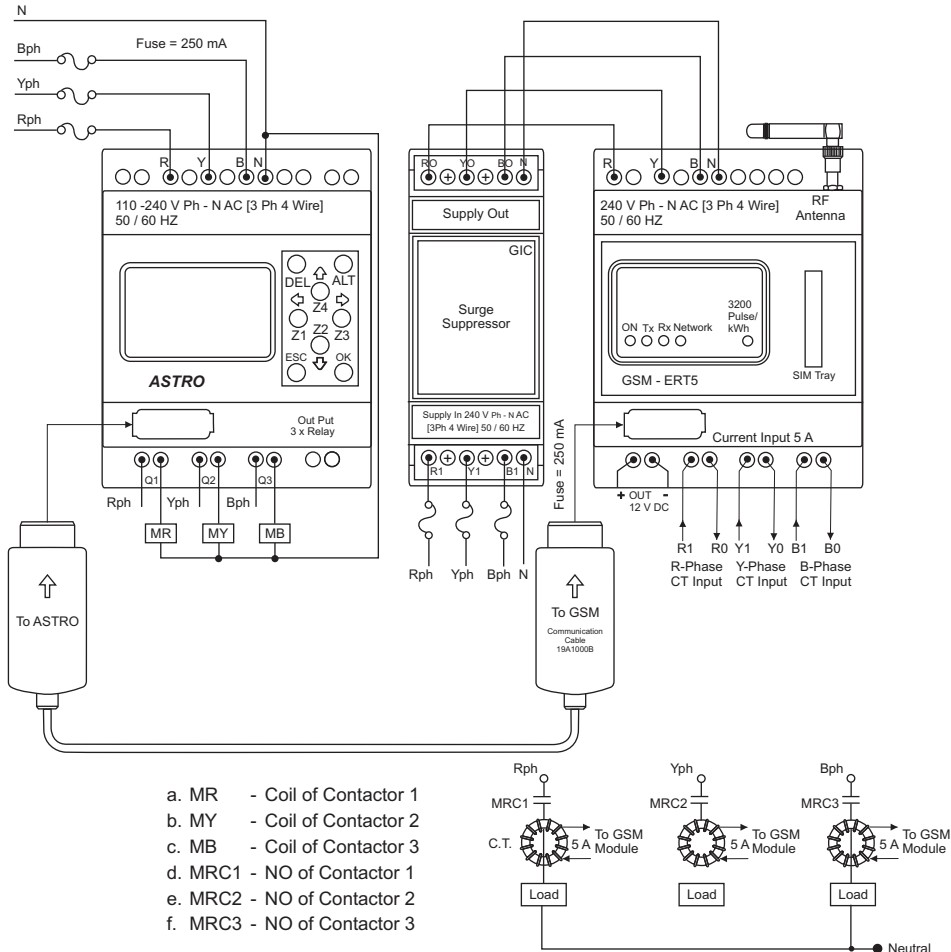

Description	Cat. No.
Astro GSM module (GSM - ERT5), Remote side	19D20B00
Astro GSM module (GSM - RT), PC side	19C20C00
Communication cable (TTL - TTL) between Astro & GSM module	19A1000B
Surge suppressor	19D2000C

Connection Diagrams



Astro using GSM Technology

Cat. No.	19D20B00 (ERT 5)	19C20C00
Supply voltage (⚡)	240 V AC (3 Phase, 4 Wire)	110 - 240 V AC (1 Phase)
Supply variation	-30% to +25%	
Frequency	50/60 Hz	
Active phase selection	Yes	
Operating temperature	-15°C to +60°C	
GSM type	Dual band 900 / 1800 GSM	
GPRS packet data	Class 10 coding scheme	
AT Command set suitability	N. A.	Yes
SMS type functionality	Data call through GSM, SMS	GSM 7.05 & 7.07
SIM holder	Text, Cell broadcast	
Antenna	Connected with the product	
Antenna impedance	50	
Energy measurement	Yes	
Energy measurement accuracy	Class 0.5	
Current sensing range	5 A	
CT ratio	Settable upto 40	
LED indications	Tx, Rx, Network, Power, Pulse out	
Pulse out rate	3200 pulses / kWh	
Auxiliary output	12 V DC, 200 mA	
General port connectivity		TTL port for connecting time-switch (Astro) USB through USB interface cable GFDNN1, RS232 through serial interface GFDNN2S, RS485 through TTL-RS485 converter G7XDTR4"
Mounting	Base/DIN rail	
Enclosure	Flame retardant UL 94-V0	
Dimension (W x H x D) (in mm)	72 x 90 x 67	
Weight (unpacked)	190 gms (approx)	
Certification	   	

Note:

- ERT5 can measure maximum 5 A current.
- Maximum current measurement limit for ERT-5 is 200 A.
Eg. For CT selection if current required to be measured is upto 200 A then CT of 200:5 A (CT ratio 40) needs to be used.

Micon 175

- Compact 17.5 mm wide
- Multiple timing ranges
- Low power consumption
- LED indication for power and relay status
- DIN rail and base mountable
- Integrated dual voltage selection



Description	Cat. No.
ON delay 0.3 sec - 30 hrs 240 V AC / 24 V AC/DC, 1 C/O, Base/DIN	12ODT4
ON delay 0.3 sec - 30 hrs 110 V AC / 24 V AC/DC, 1 C/O, Base/DIN	11ODT4
ON delay 0.3 sec - 30 hrs 12 V DC, 1 C/O, Base/DIN	15ODT4
One shot 0.3 sec - 30 hrs 240 V AC / 24 V AC/DC, 1 C/O, Base/DIN	12BDT4
One shot 0.3 sec - 30 hrs 110 V AC / 24 V AC/DC, 1 C/O, Base/DIN	11BDT4
One shot 0.3 sec - 30 hrs 12 V DC, 1 C/O, Base/DIN	15BDT4
Star delta timer, 3 sec - 120 sec, 240 V AC, 1NO (Star) + 1 NO (Delta), Base/DIN	12SDT0
Star delta timer, 3 sec - 120 sec, 240 - 415 V AC, 1NO (Star) + 1 NO (Delta), Base/DIN	14SDT1S
Multifunction timer 10 functions 0.1 s - 100 h 12 - 240 V AC/DC 1C/O Base/DIN	1CMDT0
Asymmetrical ON / OFF & OFF / ON 0.1 sec - 100 hrs, 12 - 240 V AC/DC, 1 C/O, Base/DIN	1CJDT0

Timing Diagrams

ON Delay

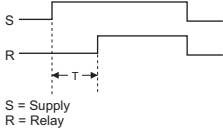

ONE Shot

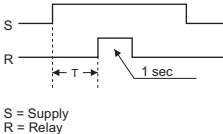

Star Delta Timer

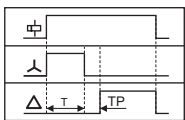

Connection Diagrams

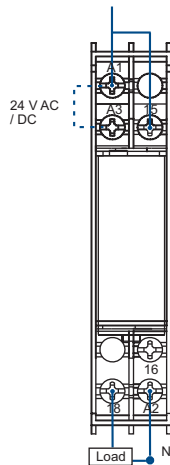

12ODT4, 11ODT4,
15ODT4, 1CJDT0,

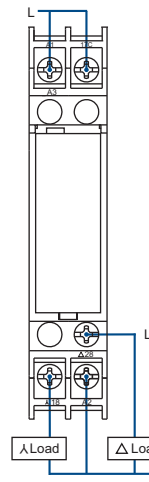

12SDT0

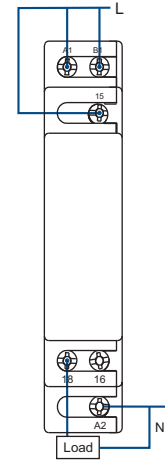

1CMDT0

Overall Dimensions

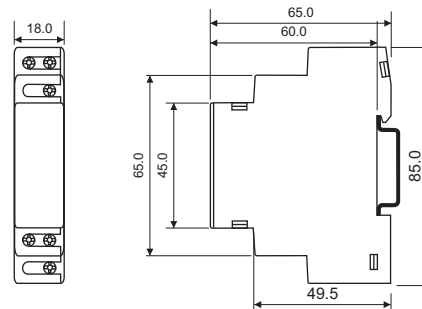
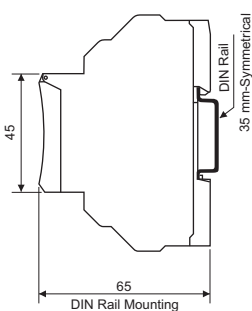
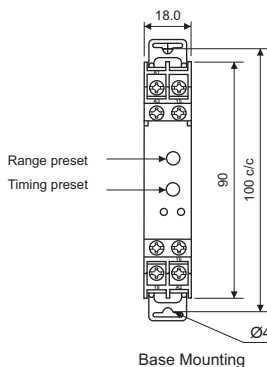

1CMDT0

Micon 175

Cat. No.	12ODT4	11ODT4	15ODT4	12BDT4	11BDT4	15BDT4
Nominal supply (Ur)	240 V AC/ 24 V DC/DC, 50/60 Hz	110 V AC/ 24 V AC/DC, 50/60 Hz	12 V DC	240 V AC/ 24 V DC/DC, 50/60 Hz	110 V AC/ 24 V AC/DC, 50/60 Hz	12 V DC
Limits	-20% to 10% of Ur					
Power consumption	15 VA					
Contact arrangement	1 C/O					
Contact rating	240 V AC/ 28 V DC @ 5 A (resistive)					
Mechanical life	5 x 10 ⁶ operations (At no load & max switching frequency)					
Electrical life						
a. 240 V AC pf = 1.0, rated max load current	1 x 10 ⁵ operations					
b. 240 V AC, pf= 0.4, rated max load current	4 x 10 ⁴ operations					
c. 30 V DC, L/R = 7 ms	6 x 10 ⁴ operations					
Switching frequency (Max)	1000 operations/hr					
Status indication on front panel	Red LED: Relay ON					
Modes available	ON Delay			One Shot		
Timing ranges 6 Ranges	3 s - 30 s, 3 m - 30 m, 3 hr - 30 hr					
Setting accuracy	±5% of full scale					
Repeat accuracy	±1%					
Variation in timing due to voltage change	±2%					
Variation in timing due to temperature change	±5%					
Reset time	100 msec (max)					
Supply indication on front panel	Green LED: Power ON					
Mounting	Base/DIN rail (35 mm sym.)					
Dimensions	17.5 ^{+0.5} / _{-0.0} (W) x 65.0 (H) x 90.0 (D) mm					
Weight (unpacked)	75 gms (approx)					
Certification						

Micon 175

Functional Diagrams For 1CMDT0

SIGNAL ON DELAY [stn]

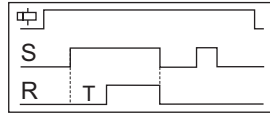

On application of input signal, the preset delay time period starts. On completion of the preset time, the output is switched ON and remains ON till the input signal is present.

ACCUMULATIVE DELAY On SIGNAL [san]

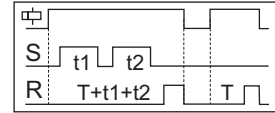

On application of supply voltage, the preset delay time period starts. If input signal is applied during this period, the preset time stops and resumes only when the input signal is removed. On completion of the preset time, the output is switched ON.

CYCLIC ON/OFF [cnf]



On application of supply voltage, the output is initially switched ON for the preset time duration (T) after which it is switched OFF for the same time duration (T). This cycle continues till the power supply is present.

IMPULSE ON/OFF [inf]

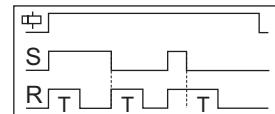

On application or removal of input signal to the timer, the output is immediately switched ON for the preset time duration (T). If the state of the input signal is changed during the preset time, the output does not change state only the time is reset.

CYCLIC OFF/ON [cfn]



On application of supply voltage, the output is initially switched OFF for the preset time duration (T) after which it is switched ON for the same time duration (T). This cycle continues till the power supply is present.

LEADING EDGE IMPULSE [iL]

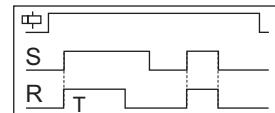

When input signal is applied to the timer the output is immediately switched ON. The output remains ON for the preset time duration (T) after which it is switched OFF. If the input signal is removed during the preset time, the output is immediately switched OFF.

SIGNAL OFF DELAY [sf]

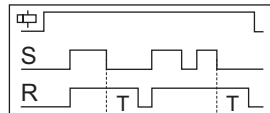

On application of input signal to the timer, the output is immediately switched ON. When the input signal is switched OFF, the preset time delay period starts. On completion of the time period the output is switched OFF.

TRAILING EDGE IMPULSE [it]

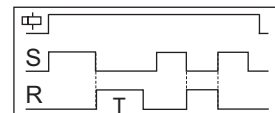

When the input signal to the timer is removed, the output is immediately switched ON for the preset time duration (T) after which it is switched OFF. If the input signal is applied during the preset time, the output is immediately switched OFF.

SIGNAL OFF/ON [sfn]

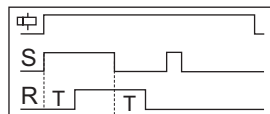

On application of input signal to the timer, the preset delay time period (T) starts. On completion of the time preset time, the output is switched ON. When the input signal is switched OFF, again the preset time delay period (T) starts. On completion of the time period the output is switched OFF.

LEADING EDGE BISTABLE [sbi]

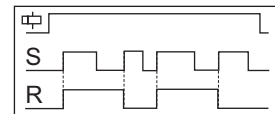

On application of input signal to the timer, the output is switched ON and remains ON even after the input signal is removed. On subsequent application of input signal, the output keeps on changing its state.

Derived Modes

Select mode, 'Signal ON Delay' and short the connection between A1 - B1 before power ON. Select mode, 'Accumulative Delay On Signal' and keep the connection between A1 - B1 open.

Select mode, 'Leading Edge Impulse' and short the connection between A1 & B1.

ON DELAY

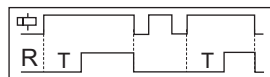



When supply power is applied to the timer, the preset delay time period starts. On completion of the preset time, the output is switched ON and remains ON till the input supply is present.

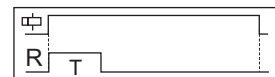

INTERVAL



When supply power is applied to the timer, the output is instantly switched ON. On completion of the preset time, the output is switched OFF.

Micon 175

Cat. No.	12SDT0	14SDT1S
Timer description	Star delta timer	
Nominal supply (Ur)	240 V AC, 50/60 Hz	240 - 415 VAC, 50/60 Hz
Limits	-20% to 10% of Ur	
Power consumption	8 VA	
Contact arrangement	Star - 1 NO, Delta - 1NO	
Contact rating	240 V AC / 28 V DC @ 5 A (resistive)	
Mechanical life	5 x 10 ⁶ operations (At no load & max switching frequency)	
Electrical life	1 x 10 ⁵ operations	
Status indication on front panel	Red LED 1 : Star ON, Red LED 2 : Delta ON	
Timing range	3 s to 120 s	3 s to 30 s
Pause time	60 ms	
Reset time	150 ms (max)	
Setting accuracy	±5% of Full scale	
Repeat accuracy	±1%	
Degree of protection	IP20 for terminals, IP40 for enclosure	
Mounting	Base/DIN rail	
Dimensions	17.5 (W) x 65.0 (H) x 90.0 (D) mm	
Weight (unpacked)	75 gms (approx)	
Certification	 	

Cat. No.	1CMDT0	1CJDT0
Timer description	Multi function timer	Assymterical timer
Modes	1) Signal ON delay	1) Assymterical ON / OFF
	2) Cyclic ON / OFF	2) Assymterical OFF / ON
	3) Cyclic OFF / ON	
	4) Signal OFF delay	
	5) Signal OFF / ON	
	6) Accumulative delay on signal	
	7) Impulse ON / OFF	
	8) Leading edge impulse	
	9) Trailing edge impulse	
	10) Leading edge bi-stable	
Derived modes	ON Delay, Interval	NA
Nominal supply (Ur)	12 - 240 V AC, 50/60 Hz	
Limits	-15% to +10% of Ur	
Power consumption	2 VA	
Contact arrangement	1 CO	
Contact rating	240 V AC / 28 V DC @ 5 A (resistive)	
Mechanical life	5 x 10 ⁶ operations (At no load & max switching frequency)	
Electrical life	1 x 10 ⁵ operations	
Status indication ON	Green LED: Power ON,	
Front panel	Yellow LED: Relay ON	
Timing range	0.1 s to 100 h	
Reset time	200 ms (max)	
Setting accuracy	±5% of full scale	
Repeat accuracy	±1%	
Degree of protection	IP20 for terminals, IP40 for enclosure	
Mounting	Base/DIN rail	
Dimensions	17.5 (W) x 65.0 (H) x 90.0 (D) mm	
Weight (unpacked)	75 gms (approx)	
Certification	 	

Micon 225

- Compact 22.5 mm wide Base/DIN rail Timer
- Multi-voltage, Multi-function & Multi-range timers
- Time range - 0.1 sec to 10 hrs
- Flush knobs for better security
- Finger proof terminals (IP20)



Description	Cat. No.
Multifunction multirange 0.1 sec - 10 hrs, 24 - 240 V AC/DC, 2 C/O, Base/DIN	2A5DT5
Star delta timer, 0.3 sec - 120 sec, 24 - 240 V AC/DC, 1NO (Star) + 1NO (Delta), Base/DIN	2ASDT0
Star delta timer, 0.3 sec - 120 sec, 240 - 415 V AC, 1NO (Star) + 1NO (Delta), Base/DIN	2BSDT0
True OFF delay 0.6 - 600 sec, 24 - 240 V AC/DC, 2 C/O	23GDT0
Multifunction timer 6 functions 0.1 sec - 10 hrs, 24 - 240 V AC/DC 2C/O (1 Inst + 1 Delayed for 6th mode) Base/DIN	2A6DT6
Signal base multi function - Multirange 0.1 sec - 10 hrs, 24 - 240 V AC/DC, 1C/O, Base/DIN	2ANDT0
ON delay 0.1 sec - 10 hrs, 24 - 240 V AC/DC, 2 C/O, Base/DIN	2A0DT5
Asymmetrical ON / OFF 0.1 sec - 10 hrs, 24 - 240 V AC/DC, 2 C/O, Base/DIN	2AADT5
Multifunction multirange 0.1 sec - 10 hrs, 240 - 415 V AC, 2 C/O, Base/DIN	2B5DT5
Multifunction timer 6 functions 0.1 sec - 10 hrs, 240 - 415 V AC 2C/O (1 Inst + 1 Delayed for 6th mode) Base/DIN	2B6DT6
Asymmetrical ON / OFF 0.1 sec - 10 hrs, 12 V DC, 2 C/O	25ADT5
ON delay, 0.1 sec - 10 hrs, 9 - 32 V DC, ON delay timer, 2 C/O	29ODT5

Connection Diagrams

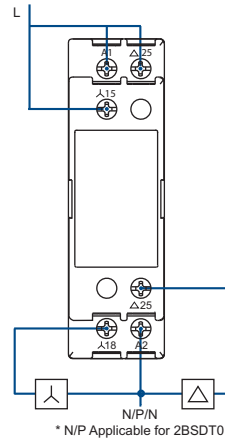

2ASDT0, 2BSDT0

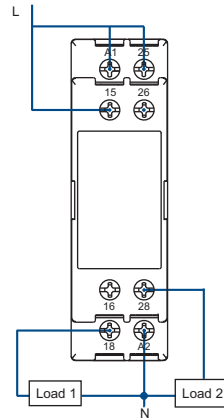

2A0DT5, 29ODT5, 2AADT5,
2A5DT5, 2B5DT5, 2A6DT6,
2B6DT6, 23GDT0, 25ADT5

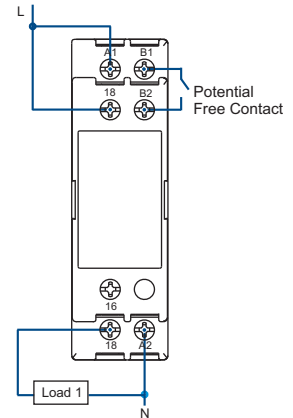

2ANDT0

Overall Dimensions

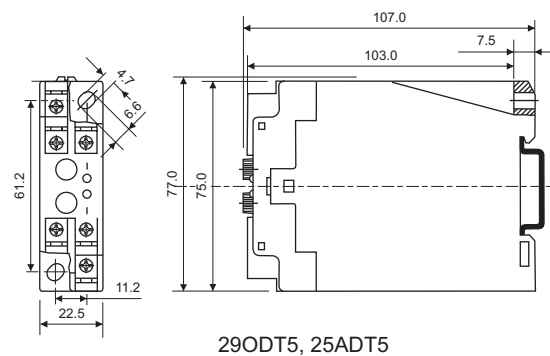
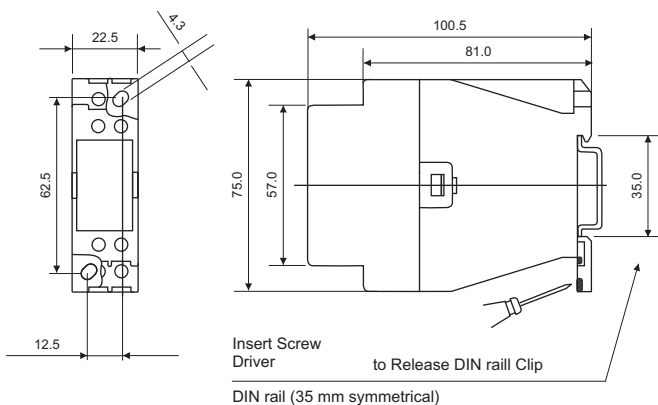

29ODT5, 25ADT5

Micon 225

Cat. No.	2A5DT5	2ASDT0	2BSDT0	23GDT0
Functions	Multi-function with 5 modes	Star - Delta		True OFF delay
Supply voltage (φ)	24 - 240 V AC/DC	24 - 240 V AC/DC	240 - 415 V AC	24 - 240 V AC/DC
Supply variation	-20% to +10% (of φ)			
Supply frequency	50/60 Hz			
Power consumption (Max.)	4 VA	4 VA	7 VA	2.5 VA
Setting accuracy	±5% of full scale			±10% of full scale
Repeat accuracy	+1%			
Initiate time	Max. 100 ms	Max. 100 ms		
Reset time	Max. 200 ms	Max. 200 ms		
Set time (Ts)	0.1s - 10 h	3 s - 120 s		0.6 - 600 s
Pause time (P)	NA	60 ms, 90 ms, 120 ms, 150 ms		NA
Operating temperature	-15°C to +60°C			
Minimum energizing time	NA			1 sec
Max. operating altitude	2000 m			
Humidity	95% (Rh)			
LED indication	Green LED : Power ON; Red : Relay ON	Star relay ON; Delta relay ON		Green LED: Power ON
Housing	Flame retardant UL 94-V0			
Dimensions in mm (WxHxD)	22.5 x 75 x 100.5			
Mounting	Base/DIN rail			
Contact rating	5 A (Res.) @ 240 V AC / 28 V DC			
Mechanical life	10 million			
Electrical life	0.1 million			
Switching frequency	Electrical: 1800 operations / h at rated load			
Utilization category	AC-15	Rated voltage (Ue): 230 V / 125 V; Rated current (Ie): 1.3 A / 2.5 A		
	DC-13	Rated voltage (Ue): 250 V / 120 V / 24 V; Rated current (Ie): 0.1 A / 0.22 A / 2 A		
Contact arrangement	2 C/O	1 NO + 1 NO		2 C/O
Degree of protection	IP20 for terminal, IP40 for housing			
Weight (unpacked)	130 gms (approx)			120 gms (approx)
Certification				

Micon 225

Timing Diagram

2A5DT5, 2B6DT6

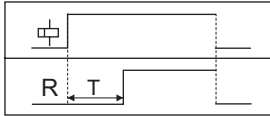

ON DELAY

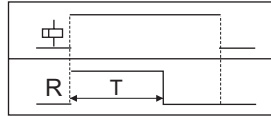

INTERVAL

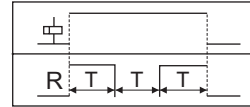

CYCLIC ON/OFF

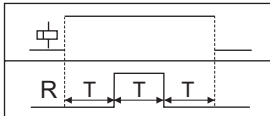

CYCLIC OFF/ON

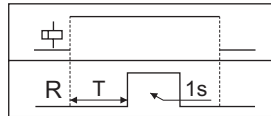

ONE SHOT

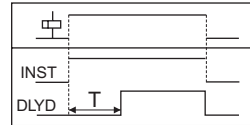

ON DELAY (1 INST. + 1 DLYD.)*

* Available only with Cat. No. 2A6DT6 & 2B6DT6

2ANDT0

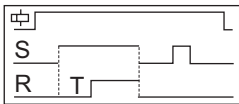

SIGNAL ON DELAY

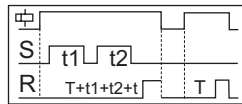

ACCUMULATIVE ON DELAY

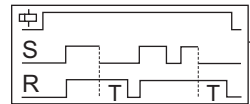

SIGNAL OFF DELAY

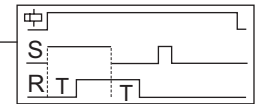

SIGNAL OFF/ON DELAY

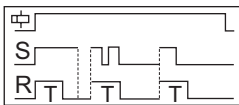

LEADING EDGE IMPULSE

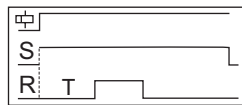

ON DELAY

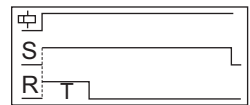

INTERVAL

2ASDT0

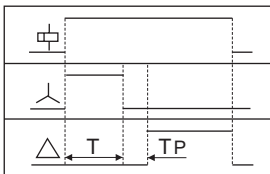

23GDT0

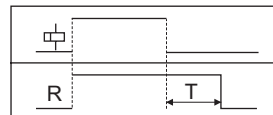

Star delta connection

Recommended Star - Delta Control Circuit:

(Below circuit is for STAR - DELTA Timer with 240 V AC Supply)

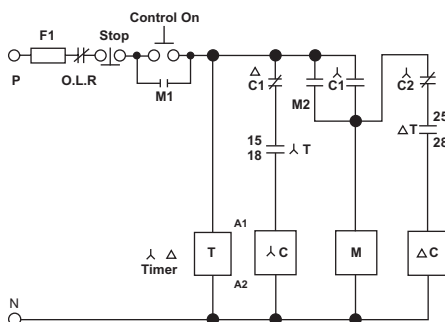

- 1) F1 - Mains Protection Fuse
- 2) O.L.R - Over Load Relay
- 3) M1 - First 'NO' Contactor Main Contactor
- 4) M2 - Second 'NO' Contactor Main Contactor
- 5) M - Main Contact of driving Motor
- 6) λ C - 'NO' Contact
- 7) λ C1 - 'NO' Contact of Star Contactor
- 8) λ C2 - 'NO' Contactor Star Contactor
- 9) Δ C - Delta Contactor
- 10) Δ C1 - 'NC' Contactor Delta Contactor
- 11) λ T - Star Contact of Timer (λ - Δ)
- 12) Δ T - Delta Contact of Timer (λ - Δ)

Micon 225

Cat. No.	2A6DT6	2ANDT0	2A0DT5	2AADT5	2B5DT5	2B6DT6
Functions	Multifunction (6 modes)	Signal based multifunction	ON delay	Asymmetric ON OFF timer	Multifunction timer 5 mode	Multifunction (6 modes)
Supply voltage	240-415 V AC	24-240 V AC/DC	24-240 V AC/DC	24-240 V AC/DC	240-415 V AC	240-415 V AC
Relay output	2 CO, 1Inst+1 delayed (for 6 mode)	1 C/O	2 C/O	2 C/O	2 C/O	2 CO, 1Inst+1 delayed (for 6 mode)
Power consumption (Max.)	7 VA	4 VA	4 VA	4 VA	7 VA	7 VA

* Other features are same as given in previous Micon 225 table on page 82.

Operating Modes / Functions of Timers

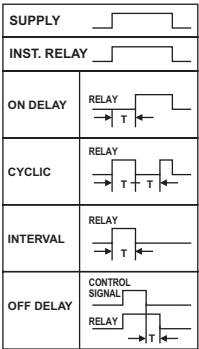
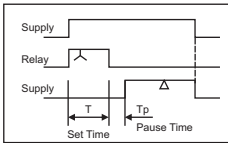
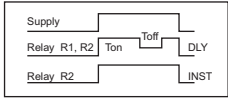
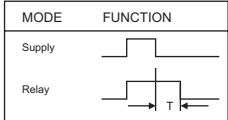
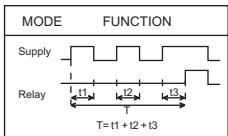
<p>MULTIFUNCTIONAL</p> 	<ul style="list-style-type: none"> • Delay on Energisation (ON Delay): The set time (Delay) start when timer receives supply. The output relay energises at the end of the pre-set time. • Cyclic Instant (Equal ON/OFF): On energisation, relay output is on and off repeatedly for the set time. Cycle starts with relay in energised condition. By removing supply, the relay gets reset. • Interval Timer: On energisation of Timer, Output relay changes the state for the time set. After completion of set time, output relay de-energises. By switching OFF supply, the Timer gets de-energised & is ready for the next cycle of the operation. • (Signal)-OFF Delay: Timer is energised and relay is in OFF condition. When control input is given through control contacts, relay is energised. Delay period commences when control input is removed. At the end of set time, relay is de-energised and load is disconnected.
<p>STAR - DELTA</p> 	<ul style="list-style-type: none"> • Star - Delta: The timer has a fixed transition time from Star to Delta connections. On energisation, the output star relay energises instantly. After completion of preset delay time, output Delta relay energises after fixed pause time. This pause time (60, 90, 120, 150 ±20 ms) provides the shortest possible 'current OFF' pause and simultaneously ensures smooth change over.
<p>ASYMMETRICAL ON/OFF</p> 	<ul style="list-style-type: none"> • Asymmetrical ON/OFF (Cyclic Instant): ON/OFF, can be independently selected from 0.1 Sec. to 10 Hrs. On energisation, relay output is ON and OFF repeatedly for the respective set times. Cycle starts with relay in energised condition. By removing supply, the relay gets reset.
<p>TRUE OFF DELAY</p> 	<ul style="list-style-type: none"> • True OFF Delay: On energisation the relay O/P is in ON position. Timing delay period commences when supply to the true OFF delay Timer goes OFF. The O/P relay de-energises at the end of pre-set time.
<p>ON DELAY (RETENTIVE/NO VOLT)</p> 	<ul style="list-style-type: none"> • ON Delay (Retentive): The set time (Delay) starts when timer receives supply. The output relay energises at the end of the pre-set time. If power fails during set time, the elapsed time will be retained by timer. Upon resumption of power, remaining cycle will continue.

Motor Restart control Timer

- Single phase motor restart control timer with memory time
- Under voltage trip and ON delay



Description	Cat. No.
240 V AC, Motor restart control timer, 1C/O	22LDT0
110 V AC, Motor restart control timer, 1 C/O	23LDT0

Working

The timer is used for instantaneous or delayed motor startup after a short-time power failure (max. 6 sec). The start occurs immediately if power supply is disrupted for less than 0.2 sec. If the power failure lasts longer, the relay activates its memory for a time that can be set to 0.2 to 6 sec, after which no automatic restart is possible.

If power supply is restored while the memory period is elapsing, the relay commands a motor restart with a delay time from power supply restoration that can be set to 0.2 to 60 sec. A system stop cancels the memory function after 50 ms, and therefore the stop signal should be on for at least this time. The relay is non-sensitive to any control voltage fluctuation or disruption during or after the motor stop.

Timing Diagrams

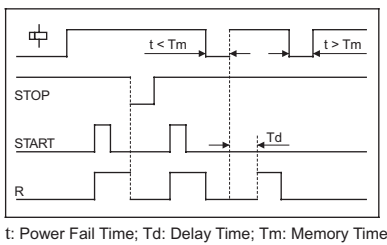

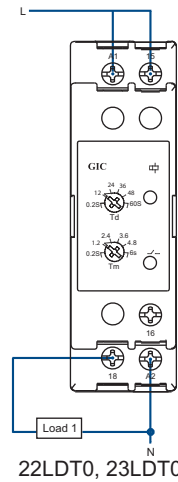

Connection Diagram

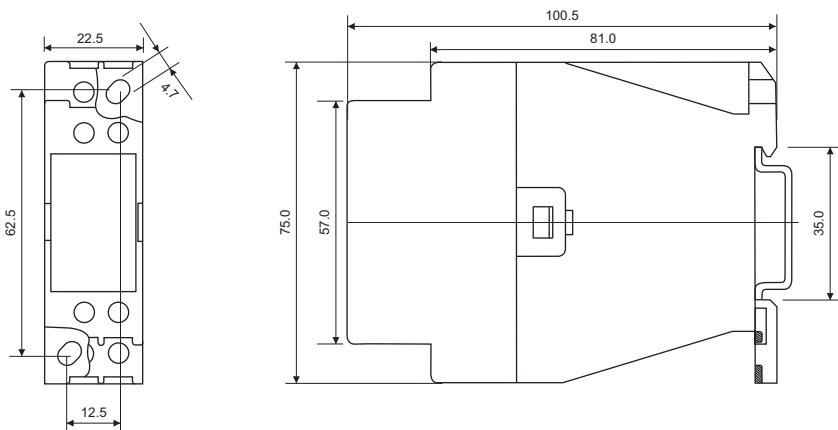

Overall Dimensions



Motor restart control Timer

Cat. No.		22LDT0	23LDT0
Nominal supply (Ur)		240 V AC, 50/60 Hz	110 V AC, 50/60 Hz
Limits		-20% to +10% of Ur	
Power consumption		4 VA	
Contact arrangement		1 C/O	
Timing ranges		Memory time TM: 0.2 to 6 s, Delay time Td: 0.2 to 60 s	
Trip voltage		176 V AC (± 6 V)	80 V AC (± 6 V)
Hysteresis		4 V AC to 10 V AC	
Reset time		200 ms (max)	
Relay output		1 C/O	
Contact rating		240 V AC / 28 V DC @ 5 A (resistive)	
Mechanical life		1 x 10 ⁷ operations	
Electrical life		1 x 10 ⁵ operations	
Operating temperature		-15°C to +60°C	
LED indication		Green LED: Power ON, Red LED: Relay ON	
Utilization category	AC-15	Rated voltage (Ue): 120/240 V, Rated current (Ie): 3.0/1.5 A	
	DC-13	Rated voltage (Ue): 24/125/250 V, Rated current (Ie): 2.0/0.22/0.1 A	
Setting accuracy		$\pm 5\%$ of full scale	
Repeat accuracy		$\pm 1\%$	
Enclosure		Flame retardant UL 94-V0	
Degree of protection		IP20 for terminals, IP40 for enclosure	
Mounting		Base/DIN rail (35 mm sym.)	
Dimensions		22.5 x 75 x 100.5 (W x H x D) mm	
Weight (unpacked)		130 gms (approx)	
Certification		  	

Brownout Timer

- Brownout Timer with 3 functions: ON Delay, Interval, Pulse
- Detects voltage dips and momentary loss of supply and resets the control panel
- LED indications for healthy and unhealthy conditions



Description	Cat. No.
ON delay 110 V AC 0.3 - 30 s, 1C/O Base/DIN	13UDT0
Interval 110 V AC 0.3 - 30 s, 1C/O Base/DIN	13UDT1
ON delayed 220 V AC 0.3 - 30 s, 1C/O Base/DIN	17UDT0
Interval 220 V AC 0.3 - 30 s, 1C/O Base/DIN	17UDT1
3 Functions 110 V AC 0.3 - 30 s, 1C/O Base/DIN	23UDT0
3 Function 240 V AC 0.3 - 30 s, 1C/O Base/DIN	27UDT0

Brownout

A dip in voltage causes electro-mechanical devices such as relays and contactors to drop out but electronic devices such as timers, programmable Relays, PLC's remain energized. As a result of this the switch sequence of the panel is lost. This can lock out all or a part of the control system causing the entire system to malfunction.

The Brownout timer also known as 'Mains restoration auto restart timer' is used for detection of voltage dips or momentary loss of supply known as Brownout and initiation of a control panel reset following the Brownout.

Timing Diagrams

23UDT0

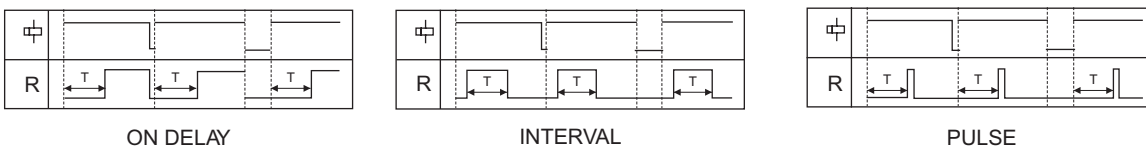

Connection Diagram

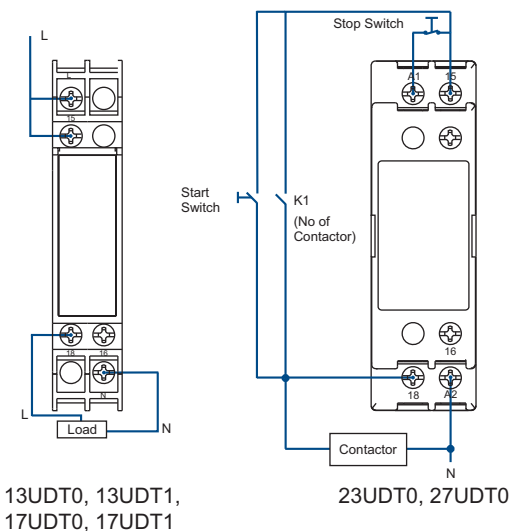

Overall Dimensions

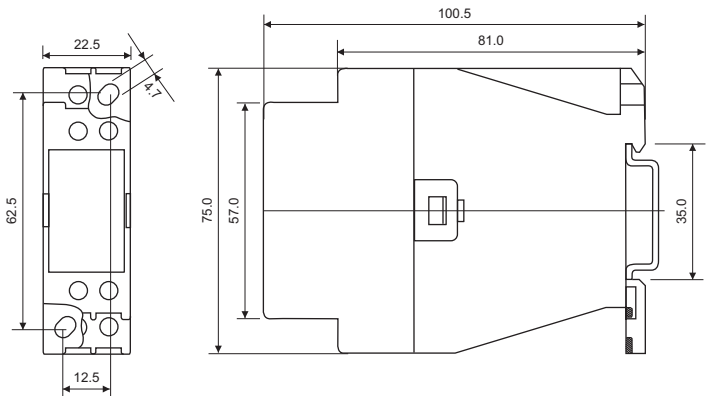

Brownout Timer

Cat. No.	13UDT0	13UDT1	17UDT0	17UDT1	23UDT0	27UDT0
Modes available	ON delay	Interval	ON delay	Interval	ON delay, Interval, Pulse	
Nominal supply (Ur)	110 V AC, 50/60 Hz		220 V AC, 50/60 Hz		110 V AC, 50/60 Hz	220 V AC, 50 Hz
Limits	-40% to +10% of Ur					
Power consumption	6 VA		10 VA		6 VA	10 VA
Contact arrangement	1 C/O					
Timing range	0.3 s to 30 s					
Contact rating	240 V AC/28 V DC @ 5 A (resistive)					
Initiate time	200 ms (max)					
Trip voltage	81 V (±6 V)		168 V (±6 V)		81 V (±6 V)	168 V (±6 V)
Recovery voltage	96 V (±4 V)		184 V (±4 V)		96 V (±4 V)	184 V (±4 V)
Response time	Voltage interruptions: 15 ms (max)					
	Voltage dips: 30 ms (max)					
Mechanical life	1 x 10 ⁷ operations					
Electrical life	1 x 10 ⁵ operations					
Status indication on front panel	Healthy condition: Flashing, Unhealthy condition: Blinking					
LED colour	Amber		Red		Amber	Red
Utilization category	AC-15	Rated voltage (Ue): 120/240 V, Rated current (Ie): 3.0 / 1.5 A				
	DC-13	Rated voltage (Ue): 24/125/250 V, Rated current (Ie): 2.0 / 0.22 / 0.1 A				
Setting accuracy	±5% of full scale					
Repeat accuracy	±1%					
Enclosure	Flame retardant UL 94-V0					
Degree of protection	IP20 for terminals, IP40 for enclosure					
Mounting	Base/DIN rail (35 mm sym.)					
Dimensions	22.5 x 75 x 100.5 (W x H x D) mm					
Weight (unpacked)	130 gms (approx)					
Certification	 					

Digicon

- Multimode timer
- Timing ranges from 0.1 sec to 999 hrs
- Wide supply
- Selectable up / down counting modes to show elapsed / remaining time
- 3 Digit LC display for preset time and run time
- LED indication of relay status
- Tamper proof with key lock function
- Finger proof terminals
- Compact size (17.5 mm single width module)



Description	Cat. No.
8 Functions, 0.1 sec - 999 hrs, 24 - 240 V AC/DC, 1 C/O Base/DIN mounting	V0DDTS
8 Functions, 0.1 sec - 999 hrs, 24 - 240 V AC/DC, 2 NO Base/DIN mounting	V0DDTD
17 Functions, 0.1 sec - 999 hrs, 24 - 240 V AC/DC, 1 C/O Base/DIN mounting	V0DDTS1
17 Functions, 0.1 sec - 999 hrs, 24 - 240 V AC/DC, 2 NO Base/DIN mounting	V0DDTD1

Connection Diagram

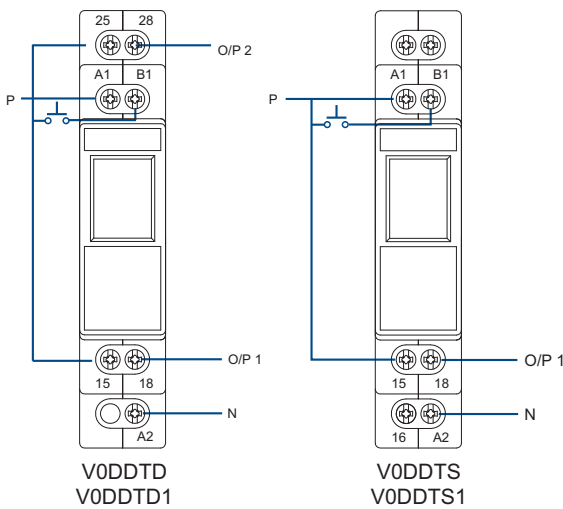

Overall Dimensions

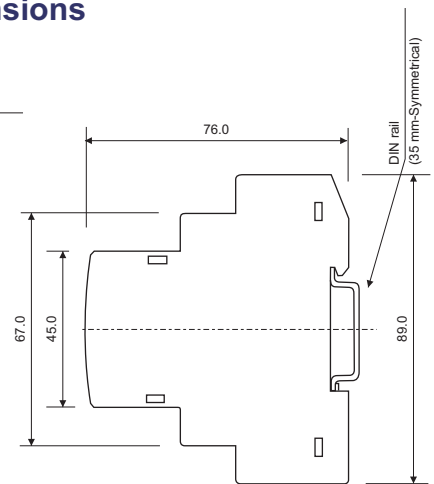

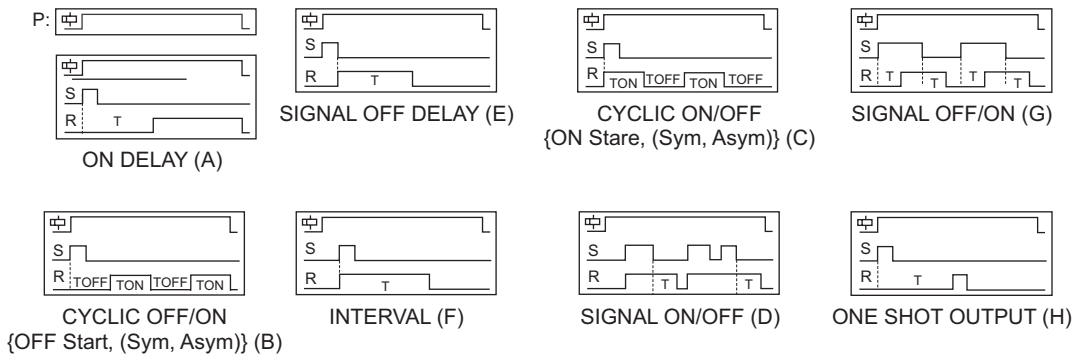

Timing Diagrams for V0DDTS & V0DDTD



Note: 1. For Power-On operation (P) connect the terminal B1 to A1 permanently.
 2. If the Signal (S) changes during the Timer Duration (T), it does not change the output relay but re-triggering takes places and the timer duration is extended.

Digicon

Cat. No.	V0DDTS	V0DDTD															
Nominal supply (Un)	24-240 V AC / DC (-15% to +10%) (50/60 Hz, ±2 Hz)																
Power consumption (Max.)	~10 VA																
Contact arrangement	1 C/O	2 NO															
Contact rating	8 A@240 V AC / 24 V DC (Resistive)																
Repeat accuracy	±0.5% of selected range																
Mechanical life	2 x 10 ⁷																
Electrical life	1 x 10 ⁵																
Switching frequency (Max.)	1800 Operations / hr @ rated load																
Status indication on panel	Red LED - Relay ON																
Modes available	1. ON Delay (A) 5. Signal OFF Delay (E) 2. Cyclic OFF / ON (Sym, Asym) (B) 6. Interval (F) 3. Cyclic ON / OFF (Sym, Asym) (C) 7. Signal OFF / ON (G) 4. Signal ON / OFF (D) 8. One Shot Output (H)																
Timing range	<table data-bbox="624 922 1439 1039"> <tr> <td>h:m</td> <td>m:s</td> <td>hr</td> <td>min</td> <td>sec</td> </tr> <tr> <td>9:59</td> <td>9:59</td> <td>999</td> <td>999</td> <td>999</td> </tr> <tr> <td></td> <td></td> <td>99.9</td> <td>99.9</td> <td>99.9</td> </tr> </table>		h:m	m:s	hr	min	sec	9:59	9:59	999	999	999			99.9	99.9	99.9
h:m	m:s	hr	min	sec													
9:59	9:59	999	999	999													
		99.9	99.9	99.9													
Variation in timing due to voltage change	±2%																
Variation in timing due to temperature change	±5%																
Operating temperature limits	-10°C to +55°C																
Humidity (Non-condensing)	93% Rh																
Mounting	Base/DIN rail (35 mm Sym.)																
Terminal capacity	1.5 mm ² (Pin type lugs)																
Certification	  																

Digicon

Timing Diagram For V0DDTS1 & V0DDTD1

ON DELAY [0]

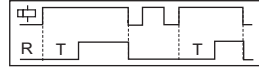

On application of supply voltage, the preset time duration (T) starts. On completion of the preset time, the output is switched ON and remains ON till the supply voltage is present.

CYCLIC OFF/ON {OFF Start, (Sym, Asym)} [1]



On application of supply voltage, the output is initially switched OFF for the preset 'OFF' time duration (TOFF) after which it is switched ON for the preset 'ON' time duration (TON). This cycle repeats and continues till the supply is present.

CYCLIC ON/OFF {ON start, (Sym, Asym)} [2]



On application of supply voltage, the output is initially switched ON for the preset 'ON' time duration (TON) after which it is switched OFF for the preset 'OFF' time duration (TOFF). This cycle repeats and continues till the supply is present.

IMPULSE ON ENERGIZING [3]

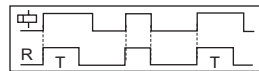

On application of supply voltage, the output is instantly switched ON for the preset time duration (T) after which it is switched OFF.

ACCUMULATIVE DELAY ON SIGNAL [4]

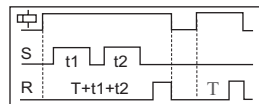

On application of supply voltage, the preset timing duration commences. When input signal is applied, the timing pauses and resumes only when the input signal is removed. The output is switched ON at the end of the preset time duration (T).

ACCUMULATIVE DELAY ON INVERTED SIGNAL [5]

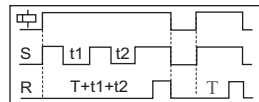

On application of supply voltage and input signal, the preset timing duration commences. When the signal is removed the timing pauses and resumes when the signal is applied. The output is switched ON at the end of the preset time duration (T).

ACCUMULATIVE IMPULSE ON SIGNAL [6]

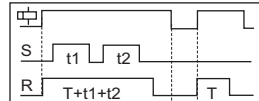

On application of supply voltage the output is switched ON & the preset timing duration commences. When the signal is removed the timing pauses and resumes when the signal is applied. The output is switched OFF at the end of the preset time duration (T).

SIGNAL ON DELAY [7]

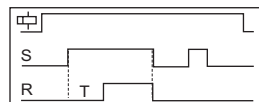

On application of input signal, the preset time duration (T) starts. On completion of the preset time, the output is switched ON and remains ON till the input signal is present

INVERTED SIGNAL ON DELAY [8]

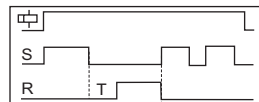

On application of supply voltage, the preset time duration (T) starts. When input signal is applied, the timing pauses & resumes only when the signal is removed. On completion of the preset time, the output is switched ON.

SIGNAL OFF DELAY [9]

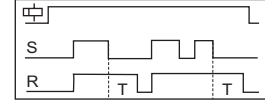

On application of supply voltage and input signal, the output is switched ON. When the signal is removed the preset time duration commences & the output is switched OFF at the end of the time duration.

IMPULSE ON/OFF [A]

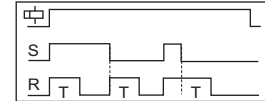

On application or removal of input signal, the output is switched ON & the preset time duration (T) starts. On completion of the time duration the output is switched OFF. When timing commences, changing the state of the input signal resets the time.

SIGNAL OFF/ON [b]

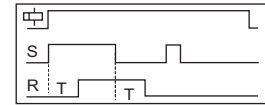

On application of input signal, the preset delay time period (T) starts. On completion of the preset time, the output is switched ON. On removal of input signal, the preset time period starts again and the output is switched ON when the preset time duration is complete.

LEADING EDGE IMPULSE1 [C]

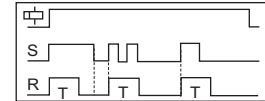

On application of input signal the output is immediately switched ON. The output remains ON for the preset time duration (T) after which it is switched OFF. If the input signal is removed during the preset time, the output remains unaffected.

LEADING EDGE IMPULSE2 [d]

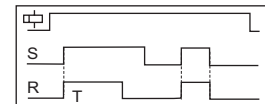

On application of input signal the output is immediately switched ON. The output remains ON for the preset time duration (T) after which it is switched OFF. If the input signal is removed during the preset time, the output is immediately switched OFF.

TRAILING EDGE IMPULSE1 [E]

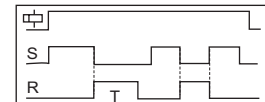

When the input signal to the timer is removed, the output is immediately switched ON for the preset time duration (T) after which it is switched OFF. If the input signal is applied during the preset time, the output is immediately switched OFF

TRAILING EDGE IMPULSE2 [F]

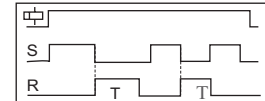

When the input signal to the timer is removed, the output is immediately switched ON for the preset time duration (T) after which it is switched OFF. If the input signal is applied during the preset time, the output remains unaffected

DELAYED IMPULSE [G]

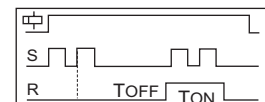

On application of input signal, the preset 'OFF' time duration (TOFF) starts. The output is switched ON at the end of the preset 'OFF' time duration & the preset 'ON' time duration commences irrespective of signal level and remains ON till the completion of 'ToN'.

□: Supply Voltage, S: Input Signal, R: Relay Output

T: Preset Time, T: Preset ON Time, T: Preset OFF Time

Digicon

Cat. No.	V0DDTS1	V0DDTD1
Nominal supply (U)	24 - 240 V AC / DC (-15 % to +10% of U) (50/60 Hz, ±2 Hz)	
Power consumption (Max.)	~10 VA	
Contact arrangement	1C/O	2 NO
Contact rating	240 V AC / 24 V DC @ 8 A (resistive)	
Mechanical life	2 x 10 ⁷	
Electrical life	1 x 10 ⁵	
Switching frequency (Max.)	1800 Operations / hr @ rated load	
Status indication on panel	Red LED - Relay ON	
Modes available	Refer 'Timing diagrams of modes'	
Timing range	h:m m:s hr min sec 9:59 9:59 999 999 999 99.9 99.9 99.9	
Repeat accuracy	±0.5% of selected range	
Variation in timing due to voltage change	±2%	
Variation in timing due to temperature change	±5%	
Temperature limits	Operating: -10°C to +55°C	
Humidity (Non-condensing)	93 % Rh	
Mounting	Base/DIN rail (35 mm Sym.)	
Initiate time	40 ms	
Reset time	<200 ms	
Isolation (Between input and output)	2.5 kV	
Degree of protection	IP30 (Enclosure), IP20 (Terminals)	
Utilization category AC-15	Ue Rated voltage V: 120/240	
	Ie Rated current I: 3.0/1.5	
Utilization category DC-13	Ue Rated voltage : 125/250	
	V Ie Rated current I : 0.22/0.1	
Weight (unpacked)	85 gms (approx)	
Certification	  	

EM series- Auto Reset Synchronous Timer

- Time delay is independent of normal voltage and temperature fluctuations
- Black pointer gives clear indication of time set on a calibrated dial while the red one indicates the time left complete the cycle
- Automatic reset on de-energisation of the clutch coil
- Base mounting or flush mounting versions
- No-volt feature is available



Cat. No.	
<p>EM 1000 Ordering Information</p> <p>Timing Ranges (SR) B □ □ □ □</p> <p>B 0.15-3.0 sec C 1.5-30 sec D 0.15-3.0 min E 1.5-30 min F 0.15-3.0 hrs G 1.5-30 hrs H 0.3-6.0 sec J 3.0-60 sec K 0.3-6.0 min L 3.0-60 min M 0.3-6.0 hrs N 3.0-60 hrs P 0.6-12 sec Q 6.0-120 sec R 0.6-12 min S 6.0-120 min T 0.6-12 hrs V 6-120 hrs</p> <p>Timing Ranges (MR) x 0.15 sec - 3.0 hrs Y 0.3 sec - 6.0 hrs Z 0.6 sec - 12.0 hrs</p> <p>Delay 1 Standard ON delay 2 With 'NO VOLT'</p> <p>Mounting B Base Mounting F Flush (Door) Mounting</p> <p>Contact 1 1 Inst + 1 Del C/O 2 1 Inst + 2 Del C/O</p> <p>Voltage 3 110 V AC 50 Hz 4 240 V AC 50 Hz C 110 V AC 60 Hz D 240 V AC 60 Hz</p>	<p>EM 2000 Ordering Information</p> <p>Timing Ranges C □ □ □ B 1</p> <p>C 1.0 - 30 sec J 2.0 - 60 sec Q 4.0 - 120 sec</p> <p>Voltage 3 110 V AC 50 Hz 4 240 V AC 50 Hz 5 415 V AC 50 Hz</p> <p>Contact 5 1 Del C/O 6 2 Del C/O</p>

Connection Diagram

EM 1000

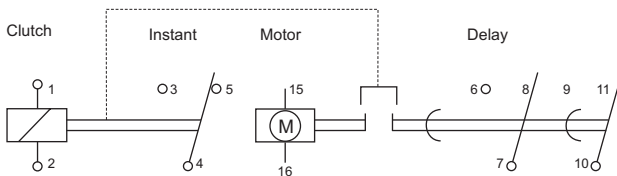

EM 2000

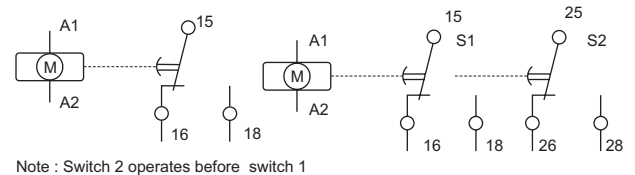

Overall Dimensions

Base Mounting

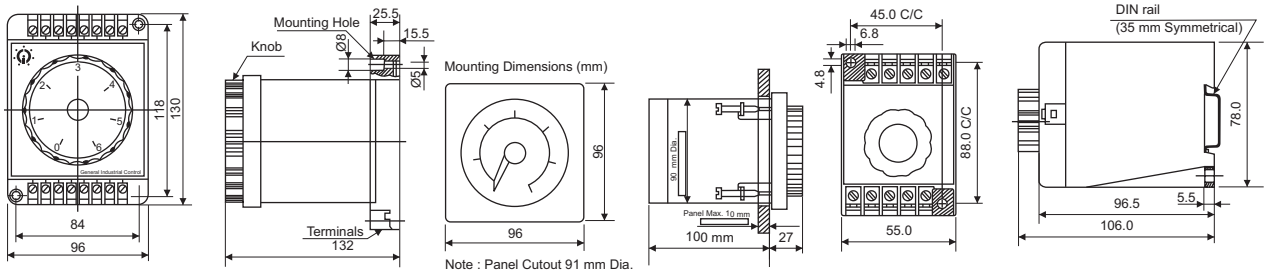

Timing Diagrams

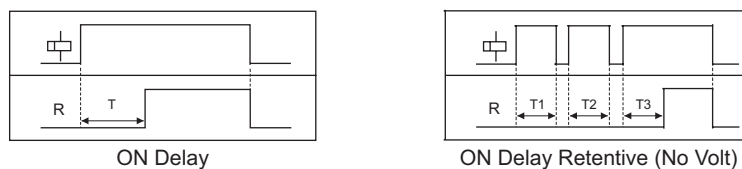

EM series- Auto Reset Synchronous Timers

EM 1000

Supply variation	-20% to 10%
Frequency	95% - 105%
Nominal consumption	10 V AC max.
Timing range	0.15 sec to 120 hrs
Repeat accuracy	± 0.5% of FSR at constant frequency
Contact rating	1 Ins t + 1 delayed - AgCdO 1 Ins + 2 delayed - AgCdO (Optional) 6 A (resistive) @ 250 V AC
Switching frequency	3000 operations / hr (Max.)
Operating temperature	-5°C to 45°C
Housing	Conforms to IP30 - IS 13947
Dimension (W x H x D)	96 x 96 x 100 (in mm)
Mounting	Flush & Base
Terminal connection	1- 2.5 mm ² solid / stranded
Protection	IP20

EM 2000

Supply variation	-20% to 10%
Frequency	95% - 105%
Timing range	1 sec to 120 sec
Accuracy: Repeat accuracy	±2% of Full scale range at constant frequency
Contact rating	1 delayed - AgCdO 2 delayed - AgCdO (optional) 5 A (resistive) @ 250 V AC
Switching frequency	1000 operations / hr (Max)
Operating temperature	-5°C to 45°C
Housing	Conforms to IP30 - IS 13947
Dimension (W x H x D)	55 x 88 x 106 (in mm)
Mounting	Base/DIN mounting & can be mounted on vertical plane with maximum inclination of 15° from vertical
Terminal connection	1 - 2.5 mm ² solid / stranded
Protection	IP20

SM 175

- Compact 17.5 mm wide
- Protects against Phase loss, Phase reversal & Phase asymmetry
- Multi voltage: 3 x 208 to 3 x 480 V
- Selectable Under voltage / Over voltage & Asymmetry
- LED Indications for all faults for changed in settings - during run time for better security
- Adjustable time delay
- 1 C/O configuration



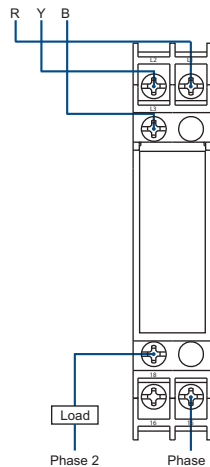

Description	Cat. No.
208 - 480 V AC, Phase loss monitoring, 1 C/O	MK21D5
208 - 480 V AC, Phase loss, Phase sequence & Phase asymmetry monitoring (fixed), 1 C/O	MC21D5
208 - 480 V AC, Phase loss, Phase sequence & Phase asymmetry monitoring (variable), 1 C/O	MA21DN
208 - 480 V AC, Under/Over voltage, Phase loss, Phase sequence with selectable ON delay, 1 C/O	MD21DF
208 - 480 V AC, Under/Over voltage & Single phasing preventer with selectable ON delay, 1 C/O	MG21DH
208 - 480 V AC, Under/Over voltage & Single phasing preventer with selectable OFF delay, 1 C/O	MG21DF

Connection Diagrams

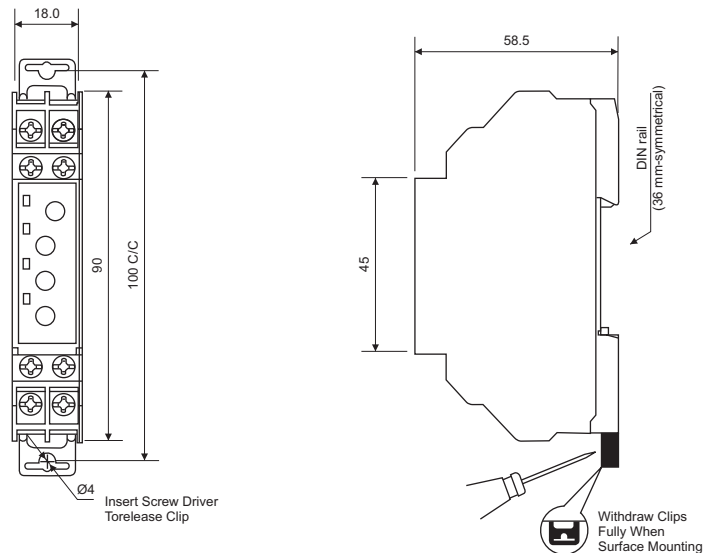
MC21D5, MK21D5, MG21DF,
MD21DF, MG21DH, MA21DN

Overall Dimensions

SM 175

Cat. No.		MK21D5	MC21D5	MA21DN	MD21DF	MG21DH	MG21DF	
Function		Phase control			Phase and Voltage control			
Supply Voltage (☉)		208 to 480 V AC, 3-Phase 3-Wire (-12% to +10%)						
Frequency		50/60 Hz						
Power consumption		3 VA (Max.)						
Adjustable nominal voltage (☉)		N. A.			208 - 220 - 380 - 400 - 415 - 440 - 480 V AC			
Trip levels	Under voltage	N. A.			-2% to -20% of ☉	-5% to -25% of ☉		
	Over voltage	N. A.			2% to 20% of ☉	5% to 25% of ☉		
	Asymmetry	N. A.	30% fixed	5% to 15%	N. A.	10% fixed		
Setting accuracy		±5% of full scale						
Time delay	Operate time	500 ms fixed		5 s fixed	5 s fixed	(< 0.5 to 100) s	5 s fixed	
	Release time	100 ms fixed		(< 0.5 to 15) s	(< 0.5 to 15) s	5 s fixed	(< 0.5 to 15) s	
Setting accuracy ±10% of Full scale		In the event of phase sequence or phase loss fault, release time is ~100 ms						
LED Indications	R/ ☉	Healthy	R Continuous ON			☉ Continuous ON		
		Phase reverse	R Flashing			☉ Flashing		
		Asymmetry	N. A.	R OFF	R OFF	N. A.		
	OV		N. A.			Over voltage		
	UV		N. A.			Under voltage		
	AS		N. A.			Asymmetry		
	All OFF		Phase fail / Supply voltage > 577. 5 V AC					
	LED's flashing		N. A.			☉ Pot changed during running conditions		
Output	Relay		1 C/O , 5 A (Res.) @ 250 V AC / 30 V DC					
	Utilization category	AC-15	Rated voltage (Ue): 120/240 V; Rated current (Ie): 3.0/1.5 A					
		DC-13	Rated voltage (Ue): 24/125/250 V; Rated current (Ie): 2.0/0.22/0.1 A					
Mechanical life		3 x 10 ⁶ operations						
Electrical life		1 x 10 ⁵ operations						
Operating temperature		-15°C to +60°C						
Humidity (Non-condensing)		95% (Rh)						
Max. operating altitude		2000 m						
Degree of protection		IP20 for terminals, IP30 for housing						
Housing		Flame retardant UL 94-V0						
Mounting		Base/DIN rail (35 mm Symmetrical)						
Dimensions in mm (W x H x D)		18 x 59 x 90						
Weight (unpacked)		70 gms (approx)						
Certifications		  						

SM 301

Supply Monitoring

- Protects against Phase loss, Phase reversal and Phase - Phase unbalance
- Compact 36 mm wide
- No auxiliary supply needed
- DIN rail and base mountable
- Voltage sensing principle
- Designed to meet industrial and agricultural segment needs



Description	Cat. No.
415 V AC, Single phase preventer with 65 V AC Asymmetry, 1 C/O	MA51BC
415 V AC, Single phase preventer with 65 V AC Asymmetry, 2 C/O	MC21B5

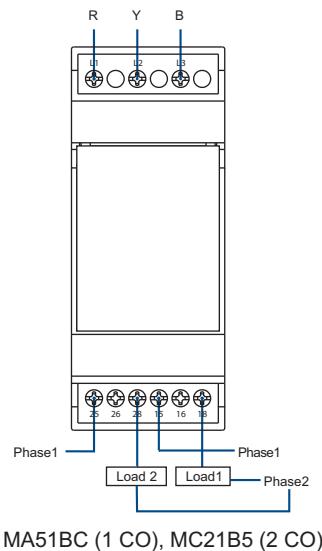

Connection Diagram

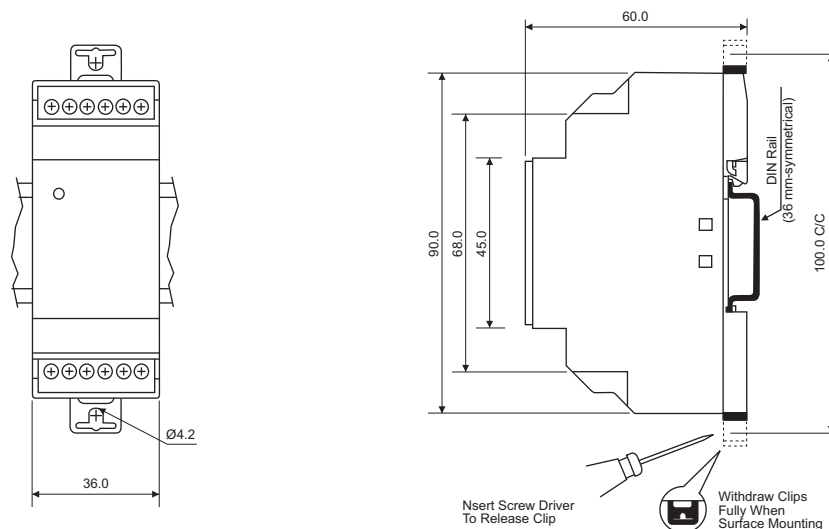

Overall Dimensions



SM 301

Cat. No.		MA51BC	MC21B5
Supply voltage (≠)		3-Phase 3-Wire, 415 V AC, 50/60 Hz	
Power consumption		15 VA (Max.)	
Trip settings:	Phase - Phase unbalance	65 V AC ±10 (fixed)	
	Unbalance hysteresis	10-18 V AC	
Time delay	ON delay	2 sec (fixed)	
	OFF delay	7 sec (fixed)	
Relay output		1 C/O (SPDT)	2 C/O
Contact rating		5 A (Res) @ 250 V AC/28 V DC	
Electrical life		1 x 10 ⁵ operations	
Mechanical life		3 x 10 ⁶ operations	
LED indication	ON	Healthy	Healthy
	OFF	Phase Loss	Phase Loss
	Fast Blink	-	Assymetry
	Slow Blink	-	Phase Sequence fault
Setting accuracy		+10% of full scale	
Operating temperature		-10°C to +50°C	
Utilization category	AC-15	Rated voltage (Ue): 125 / 240 V, Rated current (Ie): 3 / 1.5 A	
	DC-13	Rated voltage (Ue): 125 / 240 V, Rated current (Ie): 0.2 / 0.1 A	
Humidity (Non-condensing limits)		Max. 95%	
Max. operating altitude		2000 m	
Degree of protection		IP20 for terminals, IP40 for housing	
Housing		Flame retardant UL 94-V0	
Mounting		Base/DIN rail (35 mm Symmetrical)	
Dimensions in mm (W x H x D)		36 x 60 x 90	
Weight (Unpacked)		120 gms (approx)	
Certifications		 	

SM 500

Three Phase Four Wire Voltage Monitoring

- Protects against Phase loss, Phase reversal and Phase-Phase unbalance
- Can be configured for 3 phase 4 wire or 1 phase system
- Selectable Over / Under voltage trip level
- Adjustable time delay
- LED indications for power and fault conditions
- Voltage sensing principle
- 1 C/O or 2 C/O configuration



Description	Cat. No.
UV + OV ON delay 0 - 15 min, 1 P / 3 P, 4 W, 1 C/O	MD71B9
UV + OV ON delay 0 - 15 sec, 1 P / 3 P, 4 W, 1 C/O	MD71BH
UV + OV OFF delay 0 - 15 sec, 1 P / 3 P, 4 W, 1 C/O	MD71BF
SPP + UV + OV ON delay 0 - 15 min, 1 P / 3 P, 4 W, 1 C/O	MG73B9
SPP + UV + OV ON delay 0 - 15 sec, 1 P / 3 P, 4 W, 1 C/O	MG73BH
SPP + UV + OV OFF delay 0 - 15 sec, 1 P / 3 P, 4 W, 1 C/O	MG73BF

Connection Diagram

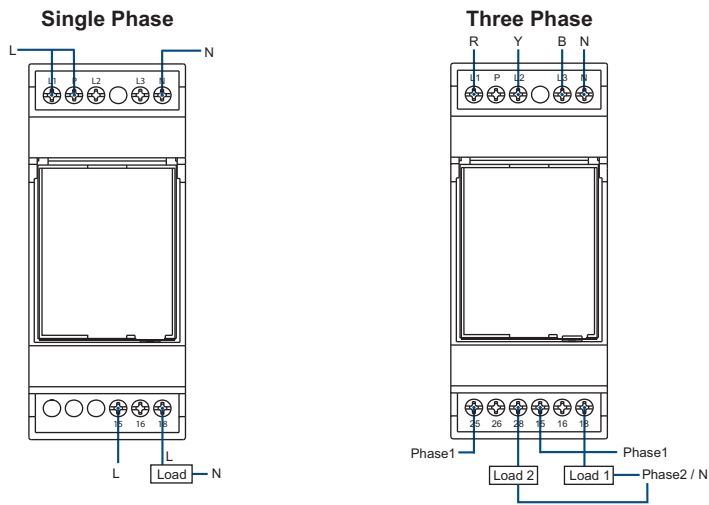

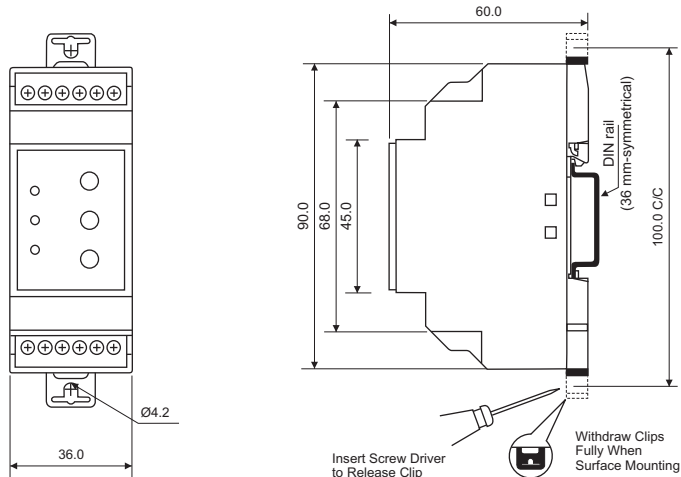

MD71BH, MD71B9, MG71BF, MG73BH, MG73B9, MG73BF

Overall Dimensions



SM 500

Cat. No.:		MD71B9	MD71BH	MD71BF	MG73B9	MG73BH	MG73BF
Function		Phase and Voltage control					
Supply voltage (φ)		1-Phase 240 V AC; 3-Phase 4-Wire 240 V AC					
Frequency		50/60 Hz					
Power consumption		5 VA (Max.)					
Trip levels	Under voltage	55% to 95% of φ					
	Over voltage	105% to 125% of φ					
	Asymmetry	N. A.			10%		
Setting accuracy		±5% of full scale					
		Note: Voltage setting are with respect to neutral					
Time delay setting accuracy ± 10% of full scale	ON Delay	0 - 15 min	0 - 15 s	5 s	0 - 15 min	0 - 15 s	5 s
	OFF Delay	5 s	5 s	0 - 15 s	5 s	5 s	0 - 15 s
LED indications	Green	Power ON					
	OV	Over voltage					
	UV	Under voltage					
	Blink	N. A.			Phase asymmetry		
	ON	N. A.			Phase reverse		
	All LEDs OFF	Phase fail					
Contact arrangement		1 C/O			2 C/O		
Contact rating		5 A (Res.) @ 250 V AC					
Mechanical life		3 x 10 ⁶ Operations					
Electrical life		1 x 10 ⁵ Operations					
Operating temperature		-10°C to +55°C					
Humidity (Non-condensing)		95% (Rh)					
Max. operating altitude		2000 m					
Degree of Protection		IP20 for terminals, IP40 for housing					
Enclosure		Flame retardant UL 94-V0					
Mounting		Base/DIN rail (35 mm Symmetrical)					
Dimensions in mm (W x H x D)		36 x 60 x 90					
Weight (Unpacked)		120 gms (approx)					
Certifications		 					

SM 500

Three Phase Four Wire Voltage Monitoring Neutral Loss protection Relay

- Monitors Own Supply
- Phase loss (failure) detection
- Neutral loss detection
- Phase reverse detection
- Phase asymmetry
- Adjustable Over & Under voltage trip level
- Fixed Operate Time & Release Time Delay
- 2 C/O Relay output (5 A, Resistive)
- DIN rail & base mounting
- LED indication for all failure conditions
- Automatic recovery on fault removal



Description	Cat. No.
SPP + Neutral Loss protection + UV + OV + ON Delay and OFF Delay 5 sec fixed, 3 Ph 4 w, 2 C/O	MAC04D0100

Functional Description:

Output Relay will energize after the operating time if the following conditions are fulfilled:

1. All phases are present and phase voltage are within the over & under voltage trip levels set on the device.
2. Neutral is present.
3. Phase Sequence is ok.
4. Phase to phase asymmetry is less than value mentioned in technical specification.

Relay will trip after the release time, if any of the above condition fails. In case of balanced load condition, if neutral is open, virtual neutral is formed at the star point, hence the product will not trip & remain healthy.

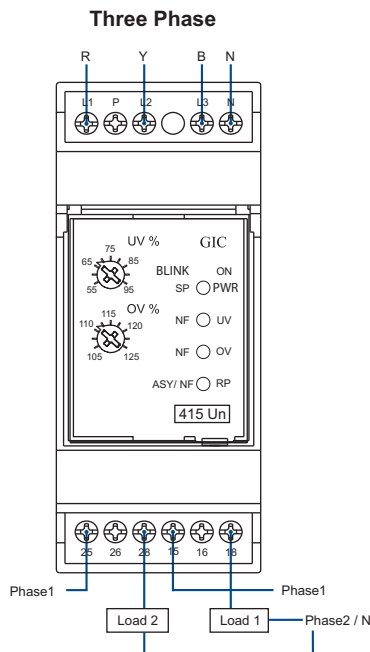

Connection Diagram:

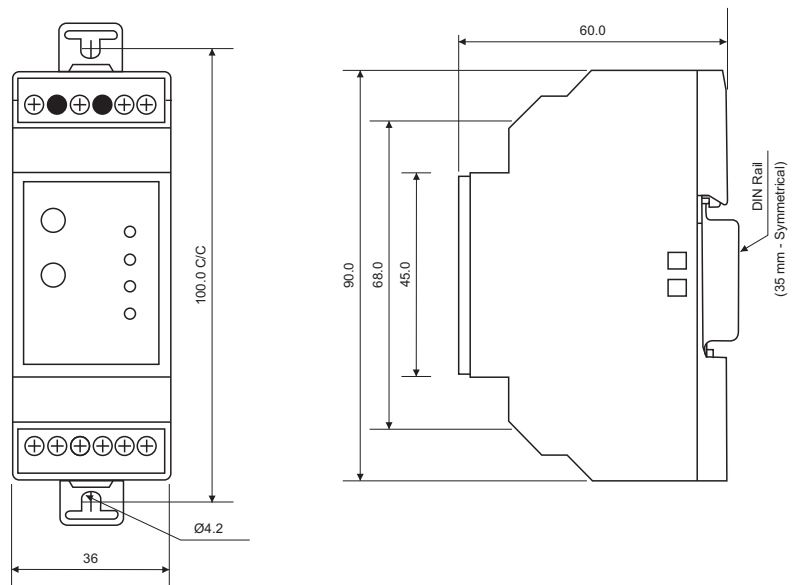

Overall Dimensions



SM 500

Cat. No.	MAC04D0100				
Function	Phase, Neutral and Voltage Control				
Supply voltage (φ)	3-Phase 4-Wire, 415 V AC				
Frequency	47 to 53 HZ				
Power consumption	10 VA (MAX.)				
Trip levels	Under voltage	55% to 95% of supply voltage			
	Over voltage	105% to 125% of supply voltage			
	Asymmetry	94 V + 4 V Ph - Ph.			
	Hysteresis	7 V + 2 V			
Setting Accuracy	± 5% of full scale				
Time delay	ON delay	5 s ± 1 s (fixed)			
	Trip time for: Phase failure Phase to phase Imbalance Under Voltage Over Voltage	5 s ± 1 s (fixed)			
	Trip time for neutral failure	500 ms to 1 s			
	Product relay will not become on, if the phase sequence is reverse at power on. If the phase sequence is reversed during running condition the product will remain healthy.				
LED indications	Respective fault condition will be indicated by LED immediately & relay will be tripped after specified trip time only.				
		Green LED	UV	OV	Blink : ASY ON : REV
	Power ON	ON	OFF	OFF	OFF
	Phase reverse	ON	OFF	OFF	ON
	Asymmetry	ON	OFF	OFF	BLINK
	UV	ON	ON	OFF	OFF
	OV	ON	OFF	ON	OFF
	Phase fail	BLINK	OFF	OFF	OFF
Neutral fail	ON	BLINK	BLINK	BLINK	
Relay output	Contact arrangement	2 C/O			
	Contact rating	5 A (Res.) @ 240 V AC			
Utilization category AC-15	Rated voltage (Ue) : 230 V / 125 V; Rated				
Utilization category DC-13	Rated voltage (Ue) : 250 V / 120 V / 24 V; Rated				
Mechanical life expectancy	1 × 10 ⁷ Operation				
Electrical life expectancy	1 × 10 ⁵ Operation				
Operating temperature	-10°C to 60°C				
Humidity (non-condensing)	95% Rh (without condensation)				
Degree of protection	IP-20 for Terminals ; IP-30 for Housing				
Housing	Flame retardant UL 94-V0				
Mounting	Base/DIN Rail (35 mm symmetrical)				
Dimensions in mm (W × H × D)	36 × 90 × 60				
Weight (Unpacked)	120 g approx				
Certification	 				

SM 501

Three Phase Three Wire UV + OV & Single Phasing Protection

- Protects against Phase loss, Phase reversal and Phase-Phase unbalance & q Under / Over voltage faults
- 3 phase 3-wire models
- Adjustable ON delay & Trip time delay
- LED indications for power ON, UV, OV and phase faults
- DIN rail and base mountable
- Compact 2M size
- Voltage sensing principle



Description	Cat. No.
SPP + UV + OV ON Delay 0-15 sec 3 Ph, 3 W-Base/DIN, 2C/O	MG53BH
SPP + UV + OV OFF Delay 0 - 15 sec 3 Ph, 3 W, 2C/O	MG53BF
SPP + UV + OV Fixed ON & OFF Delay, 94 V Asymmetry 3 Ph, 3 W, 2C/O	MG53BI
SPP + UV + OV Fixed ON & OFF Delay, 3 min ON Delay 3 Ph	MG53BO
SPP + UV, Adj Asymmetry 5-17%, Delay (0-15 sec), 2C/O	MB53BM
SPP + UV + OV ON Delay, 220 V AC 0-15 sec 3 Ph, 3 W, 2C/O	MG63BH
SPP + UV + OV OFF Delay, 220 V AC 0-15 sec 3 Ph, 3 W, 2C/O	MG63BF

Connection Diagram

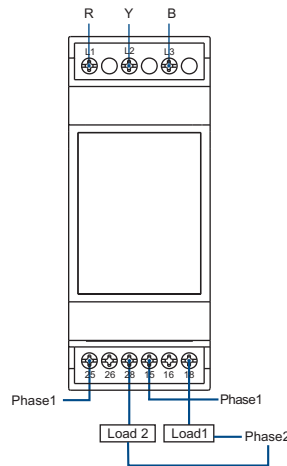

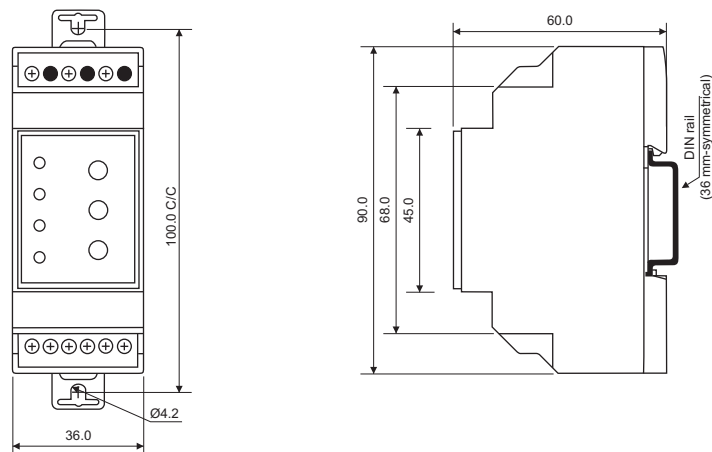

MB53BM, MG53BI, MG53BH, MG53BF, MG53BO,
for 220 VAC : MG63BH, MG63BF

Overall Dimensions



SM 501

Cat. No.		MG53BH	MG53BF	MG53BI	MG53BO	MB53BM	MG63BH	MG63BF	
Supply voltage (≡)		3 Phase 3 Wire, 415 V AC					3 Phase, 3 Wire, 220 V AC		
Frequency		50/60 Hz							
Power consumption		10 VA (Max.)					5 VA (Max.)		
Trip levels	Under voltage	55% to 95% of ≡			85% Fix	Voltage 80% of ≡ (Fix)	55% to 95% of ≡		
	Over voltage	105% to 125% of ≡			110% Fix	N. A.	105% to 125% of ≡		
	Asymmetry	10%	94 Volt	10%	5% to 17%	10%			
Setting accuracy		±5% of full scale							
Time delay	ON delay	(<0.5-15) s	5 s	5 s	3 min	(<0.5-15) s	(<0.5-15) s	5 s	
	OFF delay	5 s	(<0.5-15) s	5 s	5 s	(<0.5-15) s	5 s	(<0.5-15) s	
	Setting accuracy	±10% of full scale							
LED indications	ON	Continuous ON	Power ON						
	UV	Continuous ON	Under voltage						
	OV	Continuous ON	Over voltage			N. A.	Over voltage		
	ASY/REV	Blinking	Phase asymmetry			N. A.	Phase asymmetry		
		Continuous ON	Phase reverse			N. A.	Phase reverse		
	ASY/REV	Continuous ON	N. A.			Phase reverse	N. A.		
	All LEDS OFF		Phase fail					Supply voltage > 577.5 V	
Relay output	Contact arrangement	2 C/O							
	Contact rating	5 A (Res.) @ 250 V AC / 30 V DC							
Utilization category	AC-15	Ue Rated voltage V: 120/240 V, Ie Rated current I: 3.0/1.5 A							
	DC-13	Ue Rated voltage V: 24/125/250 V, Ie Rated current I: 2.0/0.22/01 A							
Mechanical life		3 x 10 ⁶ operations							
Electrical life		1 x 10 ⁵ operations							
Operating temperature		-15°C to +55°C							
Humidity (Non-condensing limits)		Max. 95%							
Max. operating altitude		2000 m							
Degree of protection		2							
Pollution degree		IP20 for terminals, IP40 for housing							
Housing		Flame retardant UL 94-V0							
Mounting		Base/DIN rail (35 mm Symmetrical)							
Dimensions in mm (W x H x D)		36 x 60 x 90							
Weight (Unpacked)		120 gms (approx)							
Certifications		 							

Supply Monitoring Series - Current Control

- Protection against Overload, Phase loss, Phase reverse and Phase unbalance faults
- Wide range of sensing current: 1 A - 45 A
- Models for 1 Phase and 3 Phase systems
- Auto / Manual reset selection
- Fail-safe protection
- Inverse time model with underload, locked rotor protection and selectable trip class
- Definite time model with underload and selectable start and trip time



Description	Cat. No.
Inverse time current monitoring relay, 3 Ph, 3 - 9 A, 1 NO	17A122CB0
Inverse time current monitoring relay, 3 Ph, 8 - 24 A, 1 NO	17A222CB0
Inverse time current monitoring relay, 3 Ph, 15 - 45 A, 1 NO	17A322CB0
Definite time current monitoring relay, 3 Ph, 3 - 9 A, 1 NO	17B122AA0
Definite time current monitoring relay, 3 Ph, 8 - 24 A, 1 NO	17B222AA0
Definite time current monitoring relay, 3 Ph, 15 - 45 A, 1 NO	17B322AA0
Inverse time current monitoring relay, 1 Ph, 3 - 9 A, 1 NO	17C112EB0
Inverse time current monitoring relay, 1 Ph, 8 - 24 A, 1 NO	17C212EB0
Inverse time current monitoring relay, 1 Ph, 15 - 45 A, 1 NO	17C312EB0
Definite time current monitoring relay, 1 Ph, 3 - 9 A, 1 NO	17D112DA0
Definite time current monitoring relay, 1 Ph, 8 - 24 A, 1 NO	17D212DA0
Definite time current monitoring relay, 1 Ph, 15 - 45 A, 1 NO	17D312DA0

Supply Monitoring Series - Current Control

The Current Monitoring Relay (CMR) provides monitoring and protection of loads against overload, underload, Phase loss, Phase asymmetry and Phase sequence faults. The CMR measures current directly through the use of built-in current transformers & can be set to detect faults for a wide range of current.

The CMR can also be used for higher current ranges by using an external CT. Under Load protection is provided by undercurrent trip to avoid dry running, cavitations, etc. Phase Loss/Imbalance protection prevents negative sequence current thus protecting the rotor winding.

There are two types of current monitoring relays: definite time based and inverse time based. In the case of definite time based relays, the trip time is settable while with inverse time relays, the trip time is inversely proportional to the current depending on the trip class. The relays protect motors from over-load and under-load conditions.

In the case of definite time relays, Under load protection is provided by undercurrent trip. It is suitable for small pumps to avoid dry running, cavitations, etc. Negative sequence current due to phase unbalance or phase loss may damage rotor winding. Relay gives excellent protection for Phase imbalance or phase loss. Relay detects the phase reversal during starting only. For this feature motor start duration should be more than 0.2 seconds. In case of Auto reset mode, relay resets approximately 15 minutes after trip in case of 3 Phase products and 10 minutes after trip in case of 1 - phase products. For all trips relay could be reset immediately. For manual reset press and hold reset switch for 2 seconds.

With inverse time relays, relay implements the thermal image of the motor during heating and cooling periods. If the motor current exceeds 1.1 times set value of the current, relay trips the motor as soon as the value of thermal capacity exceeds threshold value. It protects motor from locked rotor conditions due to mechanical fault or due to high inertia load.

The applications include all motor and pump protection panels with single phase and three phase supply.

Supply Monitoring Series - Current Control

Product		Three Phase						Single Phase					
		P1	P2	P3	P4	P5	P6	P7	P8	P9	P10	P11	P12
Auxiliary supply		220 to 415 V AC, -20% to +15%, 50/60 Hz						110 to 240 V AC, -20% to +10%, 50/60 Hz					
Power consumption (Max.)		10 VA (approx)						5 VA (approx)					
LED Indication	Power ON	ON (Green LED)											
	OL (Over load)	ON (Red LED 1)											
	UL (Under load)	ON (Red LED 2)											
	Phase REV. / UNB	ON: Phase reverse / Blink : Imbalance (Red LED 3)						N. A.					
	Phase loss indication	All LEDs are OFF						N. A.					
Relay contact arrangement & rating		1 NO (Fail safe operation) 5 A @ 240 V AC											
Utilization category AC-15		Ue Rated voltage V : 120 / 240 V, Ie Rated current I: 3.0 / 1.5 A I											
Mechanical life		1 x 10 ⁷ Operations											
Electrical life		1 x 10 ⁵ Operations @ rated load											
Number of CTs		2						1					
Trip characteristics		Inverse time			Definite time			Inverse time			Definite time		
Thermal memory		Yes			NA			Yes			NA		
Trip class (IEC 60947-4-1)		10 A, 10, 20 , 30			NA			5, 10, 20, 30			NA		
Start time		NA			0.2 to 30 s			NA			0.2 to 30 s		
Delay time		NA			0.2 to 10 s			NA			0.2 to 10 s		
Under load protection		40% to 90% (Trip time < 5 s)			50% (Trip time: < 5 s)			40% to 90% (Trip time < 5 s)			50% (Trip time: < 5 s)		
Locked rotor protection		300% of the set Value trip time: < 3 s after starting			N A			300% of the set value trip time:< 3 s after starting			NA		
Phase imbalance protection		50% Imbalance (Trip time < 5 s)						NA					
Phase loss protection		70% Imbalance (Trip time < 3 s)						NA					
Phase reverse protection		Yes, 0.2 s approx						NA					
Reset mode		Auto / Manual											
Test function		Yes											
Setting accuracy		±5%											

Table continued on page 108

Three Phase Products

	Cat. No.	Trip Char.	Current
P1	17A122CB0	Inverse	3 A to 9 A
P2	17A222CB0	Inverse	8 A to 24 A
P3	17A322CB0	Inverse	15 A to 45 A
P4	17B122AA0	Definite	3 A to 9 A
P5	17B222AA0	Definite	8 A to 24 A
P6	17B322AA0	Definite	15 A to 45 A

Single Phase Products

	Cat. No.	Trip Char.	Current
P7	17C112EB0	Inverse	3 A to 9 A
P8	17C212EB0	Inverse	8 A to 24 A
P9	17C312EB0	Inverse	15 A to 45 A
P10	17D112DA0	Definite	3 A to 9 A
P11	17D212DA0	Definite	8 A to 24 A
P12	17D311DA0	Definite	15 A to 45 A

Connection Diagram

Single Phase

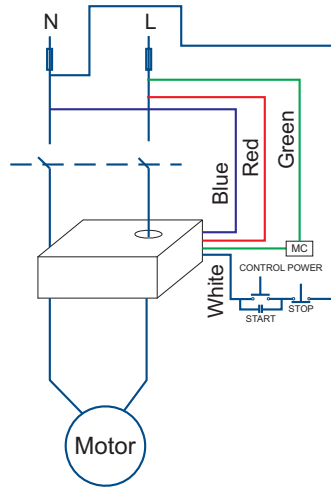

MANUAL RESET

17C122EB0, 17D112DA0, 17C21EB0,
17D212DA0, 17C312EB0, 17D312DA0

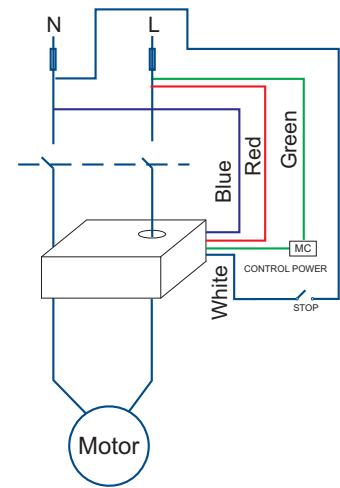

AUTO RESET

Three Phase

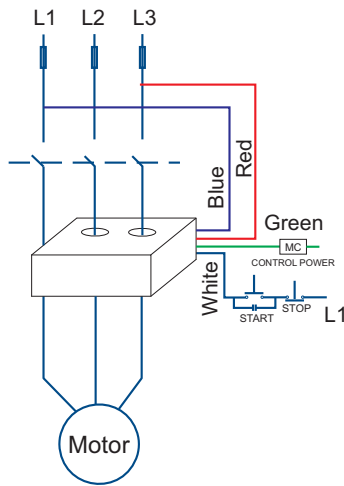

MANUAL RESET

17A122CB0, 17B122AA0, 17A222CB0,
17B222AA0, 17A322CB0, 17B322AA0

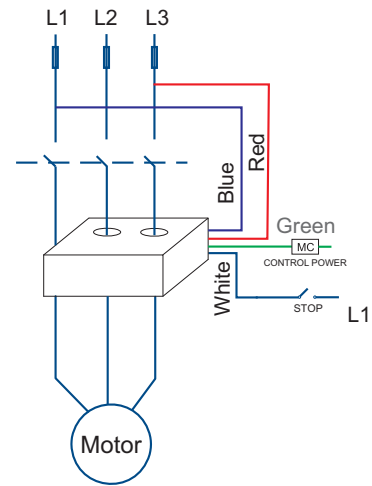

AUTO RESET

Overall Dimensions

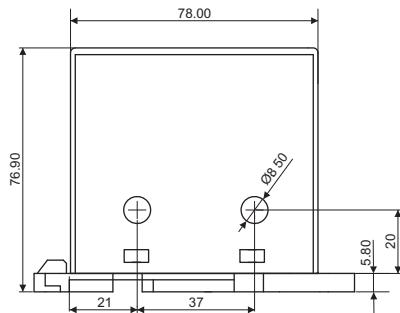
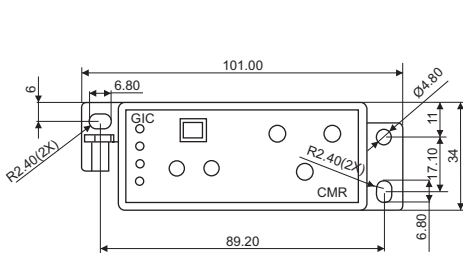

3 - Phase

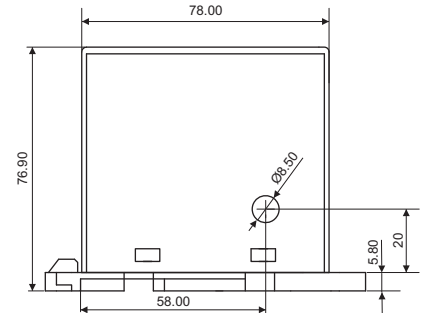

1 - Phase

All dimensions are in mm

Supply Monitoring Series - Current Control

Product	Three Phase						Single Phase					
	P1	P2	P3	P4	P5	P6	P7	P8	P9	P10	P11	P12
Repeat accuracy	±2%											
ON delay	450 ms ± 50 ms											
Reset time	< 300 ms											
Type of insulation	Reinforced insulation											
Dimensions in mm (W x H x D)	101 x 34 x 76.9											
Mounting	Base mounting											
Weight approx (Unpacked)	210 g approx											
Degree of protection	IP40 for enclosure											
Operating position	Any											
Maximum operating altitude	2000 m											
Operating temperature	-10°C to +60°C											
Relative humidity	95% Rh (without condensation)											
Number of wires	4 (L1, L2, 15, 18)						4 (L1, N, 15, 18)					
Size & length of wires	1 mm ² , 65 cm Length											
Max. size of wire passing thro. CT	16 mm ²											
Auto reset time	15 min						10 min					
Manual reset	Immediate											
Product certification												

Inverse trip characteristic curves:

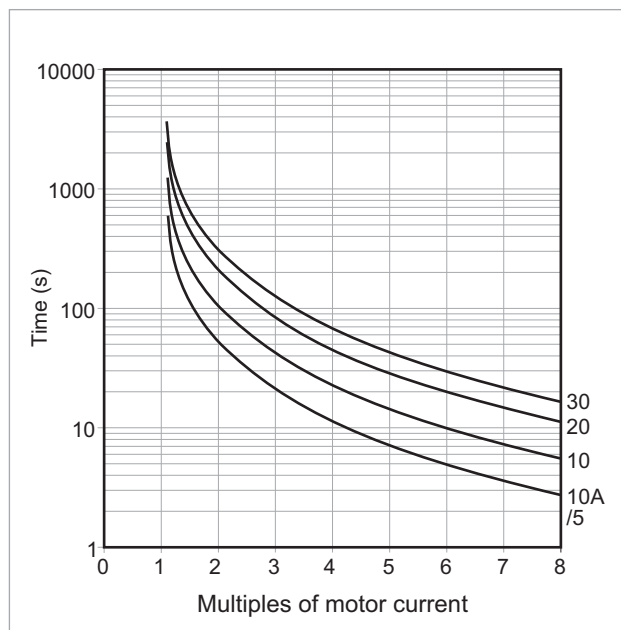

Frequency Monitoring Relay Series

- Models for Over frequency and Under / Over frequency monitoring
- Monitors frequency of three signals - Sine, Square & Triangular
- Model for frequency limit control: 5 Hz to 135 Hz
- Wide signal Input voltage: 15 to 500 V AC
- Ease of frequency setting with simple addition & subtraction
- LED indications for healthy, unhealthy & no signal conditions



Description	Cat. No.
110-240 V AC, Over frequency monitoring series PD 225 with ON delay of 500 ms (Fixed), & OFF delay of 500 ms (Fixed), 1 C/O	MI81BJ
220-440 V AC, Over frequency monitoring series PD 225 with ON delay of 500 ms (Fixed), & OFF delay of 500 ms (Fixed), 1 C/O	MI91BJ
10-240 V AC, Under/Over frequency monitoring series PD 225 with ON delay of 500 ms (Fixed) & OFF delay of 500 ms to 5 Sec. (Selectable), 1 C/O	MI81BL
220-440 V AC, Under/Over frequency monitoring series PD 225 with ON delay of 500 ms (Fixed) & OFF delay of 500 ms to 5 Sec. (Selectable), 1 C/O	MI91BL

Connection Diagram

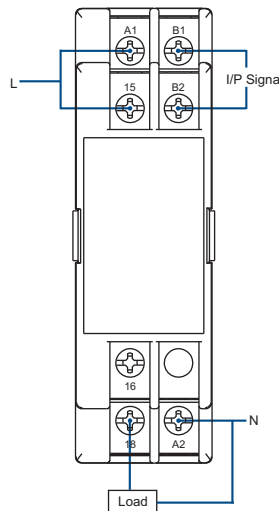





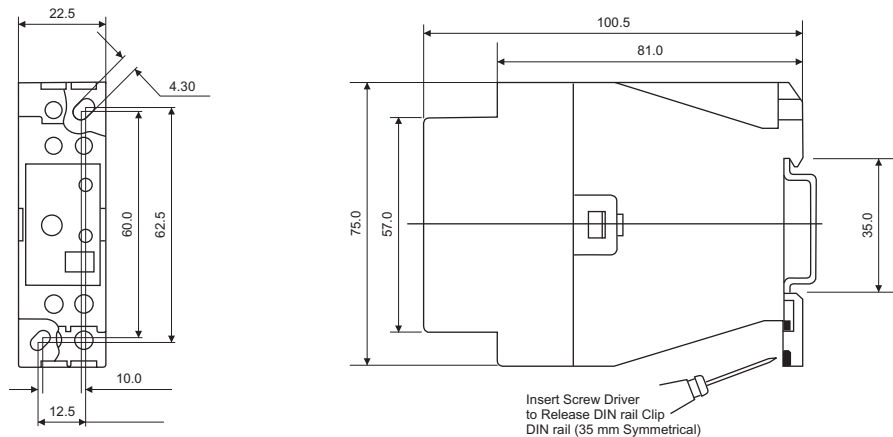



MI81BJ, MI91BJ, MI81BL, MI91BL

Overall Dimensions



Frequency Monitoring Relay Series

Cat. No.		MI81BJ	MI91BJ	MI81BL	MI91BL	
Supply voltage (Un)		110-240 V AC	220-440 V AC	110-240 V AC	220-440 V AC	
Supply variation		-15% to +15% of Un				
Supply frequency		48/62 Hz				
Power consumption		3 VA				
Contact rating		1 C/O, 6 A @ 240 V AC / 28 V DC (Resistive)				
Utilization category	AC-15	Ue Rated voltage: 120 / 240 V, Ie Rated current: 3 / 1.5 A				
	DC-13	Ue Rated voltage: 125 / 250 V, Ie Rated current: 0.22 / 0.1 A				
Mechanical life		3 x 10 ⁶ operations				
Electrical life		1 x 10 ⁵ operations				
Signal type (Sig)		Sinusoidal, Square, Triangular				
Signal input voltage range		(15 to 500) V				
Overall frequency range		(5 to 135) Hz			(40 to 70) Hz	
Frequency range selection		A	B	Frequency range		
		0	0	(5 to 15) Hz	50 Hz	
		1	0	(15 to 45) Hz		
		0	1	(45 to 135) Hz	60 Hz	
		1	1	N. A.		
Trip levels	Over frequency (F _{OVr})	0.33 to 1 of full scale			(+1 to +10) Hz	
	Under frequency (F _{UND})	N. A.			(-1 to -10) Hz	
Trip levels for signal frequency	Reset hysteresis (%) (F _{RST})	1.5 % of full scale selected			Not applicable	
	Setting accuracy (%)	+5%				
	Repeat accuracy (%)	+0.02%				
	Operate time (OT)	500 ms (Fixed)				
Response time	Release time (RT)	500 ms (Fixed)			500 ms - 5 s	
	Reset time	< 150 ms				
LED indications	 Green LED	Continuous OFF	Power fail			
		Continuous ON	Power supply healthy			
	 Er  Red LED	Continuous ON	Relay ON			
		Continuous OFF	Relay OFF			
		Flashing	No signal			
	UF Red LED	Continuous OFF	Not applicable			F _{IN} > F _{UND} Under frequency signal
		Continuous ON	Not applicable			
	OF Red LED	Continuous OFF	Not applicable			F _{IN} < F _{UND} Over frequency signal
		Continuous ON	Not applicable			
	All LEDs	Continuous OFF	Power fail			
Flashing		Switch position is changed during runtime				
Degree of protection		IP40 for Enclosure, IP20 for Terminals				
Operating temperature		-20°C to +80°C				
Relative humidity		95% (without condensation)				
Operating position		Any				
Maximum operating altitude		2000 m				
Certifications		    				

PTC Thermistor Relay Series

- Monitors and protects motors with integrated PTC resistor sensors
- Protection against over heating for heavy duty load, high switching frequency, high operating temperature & insufficient cooling conditions
- Reset Options: Manual, Automatic and Remote



PTC Thermistor Relay with Single Phasing Protection

- Thermistor Relay with protection against phase faults such as Phase Sequence, Symmetrical phase loss, Phase unbalance.
- Independent trip for Thermistor fault and SPP fault.
- LED indications for healthy, unhealthy, Sensor open/short conditions, Phase Faults conditions.

Description	Cat. No.
110 - 240 V AC, Thermistor series PD 225, 1 C/O	MJ81BK
220 - 440 V AC, Thermistor series PD 225, 1 C/O	MJ91BK
24 V AC/DC, Thermistor series PD 225, 2 C/O	MJA3BK
110 - 240 V AC, Thermistor series PD 225, 2 C/O	MJ83BK
220 - 440 V AC, Thermistor series PD 225, 2 C/O	MJ93BK
230 V AC, Thermistor + SPP series, 1 NO + 1 NO	ML64BS
230 V AC, Thermistor + SPP series, 1 NO + 1 NC	ML67BS
400 V AC, Thermistor + SPP series, 1 NO + 1 NO	MLD4BS
400 V AC, Thermistor + SPP series, 1 NO + 1 NC	MLD7BS

Connection Diagram

PTC Thermistor Relay Series

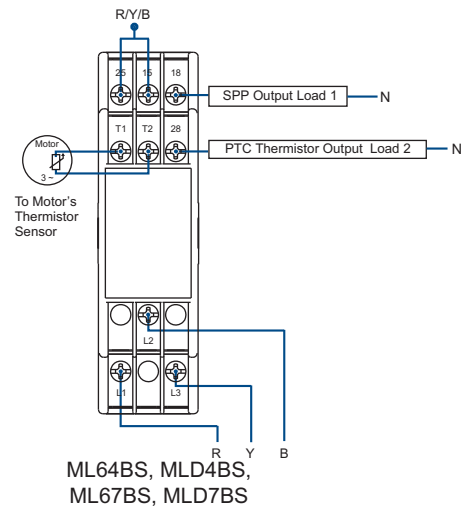
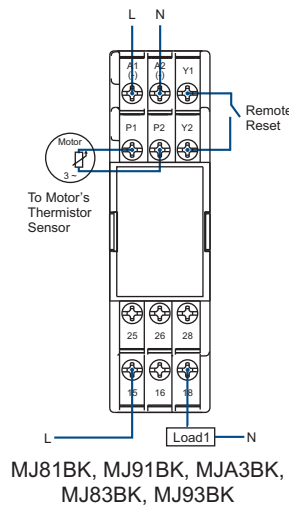



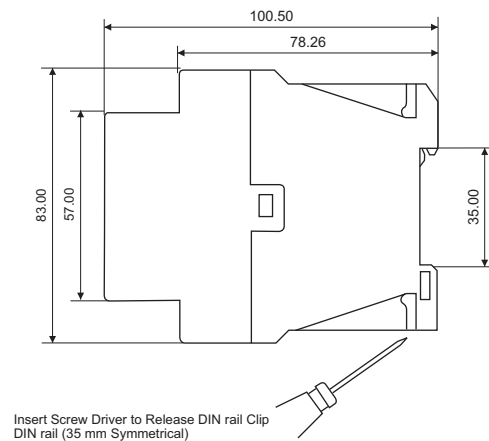
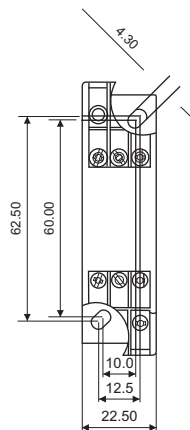

Overall Dimension

PTC Thermistor Relay Series



PTC Thermistor Relay Series

Cat. No.		MJ81BK	MJ91BK	MJA3BK	MLB4BK	MLC4BK
Supply voltage (Un)		110 to 240 V AC, (50/60 Hz)	220 to 440 V AC, (50/60 Hz)	24 V AC/DC, (50/60 Hz)	3 Ph - 3 Wire 230 V AC (50/60 Hz)	3 Ph - 3 Wire 400 V AC (50/60 Hz)
Supply tolerance		-20% to +10% of Un			+15% of Un	
Power consumption		8 VA		2 VA	1 VA	2 VA
Contact arrangement		1 C/O		2 C/O	1 NO + 1 NO	
Contact rating		6 A @ 250 V AC / 28 V DC			5 A (NO) and 3 A (NC) @ 240 V AC / 28 V DC	
Utilization category	AC-15	Ue rated voltage V Ie rated current A		120 / 240 3.0 / 1.5		120 / 240 3.0 / 1.5
	DC-13	Ue rated voltage V Ie rated current A		24 / 125 / 250 2.0 / 0.22 / 0.1		24 / 125 / 250 2.0 / 0.22 / 0.1
Mechanical life		3 x 10 ⁶ operations				
Electrical life		1 x 10 ⁵ operations				
Phase unbalance		NA		70 V AC ± 10 V AC	104 V AC ± 10 V AC	
Asymmetrical phase loss (single phase)		NA		110 V AC ± 10 V AC	220 V AC ± 10 V AC	
Symmetrical phase loss (all phases)		NA		130 V AC ± 10 V AC	250 V AC ± 10 V AC	
Restart voltage		NA		145 V AC ± 10 V AC	265 V AC ± 10 V AC	
Trip Resist		1.33 k Ω to 2.85 k Ω				
Reset level		< 1.47 k Ω				
Sensor short		20 Ω ± 4 Ω				
Sensor short hysteresis		20 Ω ± 4 Ω				
Sensor open		20 k Ω + 5%				
Max. cold resistance of sensor chain		20 k Ω to 1.33 k Ω				
Reset mode		Manual reset / Auto reset / Remote reset			Auto	
Manual Reset mode		Manual reset using RESET key			Auto	
Repeat accuracy		1%				
Response time	Operate time (OT)	80 to 150 ms			120 ms to 380 ms	
	Release time (RT)	~ 100 ms			1) 360 to 550 ms for Asymmetrical or Symmetrical Phase Fault 2) 100 ms max for phase sequence & thermistor trip	
	Reset time	~ 150 ms			100 to 550 ms	
LED indications		Continuous ON	Power supply healthy			Power supply healthy
		Continuous OFF	Power fail			Power fail
		Flashing	Sensor open			Sensor open
		Continuous ON	Relay ON			Over Thermistor trip
		Continuous OFF	Relay OFF			Thermistor relay ON
		Flashing	Sensor Short or Cable Short			Sensor short
	Continuous ON	N. A			SPP Relay Trip (For supply above restart voltage)	
	Continuous OFF				SPP relay ON Supply and SPP Fault below restart voltage	
Terminal capacity		(1 to 4) mm ²				
Mounting / Dimensions (W x H x D)		Base or / DIN rail / (22.5 x 83 x 100.5)				
Weight (Unpacked)		~ 120 g (approx)			~ 120 g (approx)	
No of sensors		3 PTC in series manufactured as per DIN 44081 or 44082				
Operating temperature		-15°C to +60°C				
Relative humidity		95% (without condensation)				
Degree of protection		IP40 Enclosure; IP20 Terminals				
Certifications		CE 				

Earth Leakage Relay

- Monitors, detects and protects power systems from leakage faults
- Wide auxiliary supply range: 110 - 240 V AC, 220 - 415 V AC
- Wide range of selectable Earth leakage current: 60 mA-300 mA, 0.2 A - 1.2 A
- Configurable Earth leakage Trip time: 100 ms - 5 s
- Easily configurable operating modes
- Test feature to check complete product functionality
- Manual / Remote reset feature
- LED indication for relay status, CT open, Earth leakage fault & test / reset switch short



F1 series (22.5 mm)



F2 series (35 mm)

Description (ELR)	Cat. No	Description (CBCT)	Cat. No
110 - 240 V AC, 60 mA - 300 mA, 1 C/O	17G514FF1	CBCT (tape wound), 35 mm, 60 mA - 300 mA	17H5NNHL3
220 - 415 V AC, 60 mA - 300 mA, 1 C/O	17G544FF1	CBCT (tape wound), 65 mm, 60 mA - 300 mA	17H5NNIL3
		CBCT (tape wound), 100 mm, 60 mA - 300 mA	17H5NNJL3
110 - 240 V AC, 0.2 A - 1.2 A, 1 C/O	17G614FF1	CBCT (tape wound), 35 mm, 0.2 A - 1.2 A	17H6NNHL3
220 - 415 V AC, 0.2 A - 1.2 A, 1 C/O	17G644FF1	CBCT (tape wound), 65 mm, 0.2 A - 1.2 A	17H6NNIL3
		CBCT (tape wound), 100 mm, 0.2 A - 1.2 A	17H6NNJL3
110 - 240 V AC, 30 mA - 30 A, Manual reset	17G715GF2	CBCT (tape wound), 38 mm, 30 mA - 30 A	17H7NNHN3
110 - 240 V AC, 30 mA - 30 A, Auto reset	17G715KF2	CBCT (tape wound), 57 mm, 30 mA - 30 A	17H7NNIN3
220 - 415 V AC, 30 mA - 30 A, Manual reset	17G745GF2	CBCT (tape wound), 92 mm, 30 mA - 30 A	17H7NNJN3
220 - 415 V AC, 30 mA - 30 A, Auto reset	17G745KF2		

Connection Diagram (F1 series)

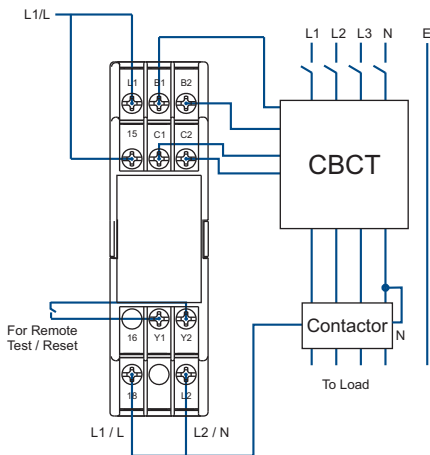
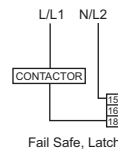
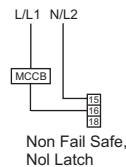
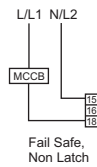
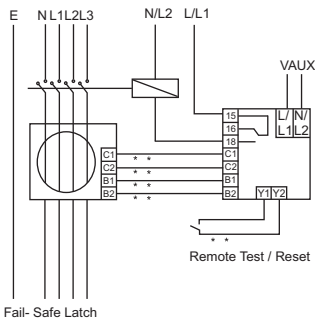

17G514FF1, 17G544FF1,
17G614FF1, 17G644FF1

Overall Dimensions (F1 series)

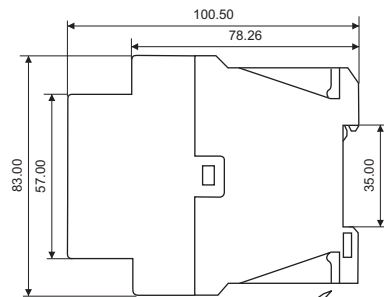
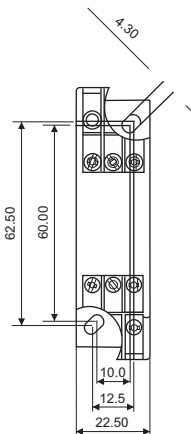

Insert Screw Driver to Release DIN rail Clip
DIN rail (35 mm Symmetrical)

Earth Leakage Relay

Cat. No.		17G514FF1	17G614FF1	17G544FF1	17G644FF1
Supply voltage (≠)		110 V to 240 V, -20% to +10%, 50/60 Hz		220 V to 415 V, -20% to +10%, 50/60 Hz	
Power consumption sensitivity		5 VA		10 VA	
LED indication	Power ON	ON (Green LED)			
	CT Open/SW Short (CT/SW)	ON:CT open, Blink: TST / RST switch short (Red LED2)			
	Earth leakage (EL)	ON (Red LED1)			
Relay		1 C/O, 5 A @ 240 V AC / 30 V DC			
Utilization category	AC-15	Ue Rated voltage: 120 / 240 V, Ie Rated current: 3.0 / 1.5 A			
	DC-13	Ue Rated voltage: 125 / 250 V, Ie Rated current: 0.22 / 0.1 A			
Mechanical life		1 x 10 ⁷ operations			
Electrical life		1 x 10 ⁵ operations			
Modes available through potentiometer		Fail safe non-latch, Fail safe latch, Non-fail safe non-latch			
Trip time or release time including relay Changeover (Adjustable parameter)		100 ms to 5 s. Gradation or dial setting: 100 ms, 200 ms, 400 ms, 2 s, 5			
Sensitivity		60 mA to 300 mA	0.2 A to 1.2 A	60 mA to 300 mA	0.2 A to 1.2 A
Trip time, When In *5		< 100 ms Irrespective of trip delay set			
Reset enable		Below 85% on current sensitivity level and in presence of CBCT			
Test / Reset facility		Yes (on Front dial & Remote) Reset only for FSL mode			
Setting accuracy		- 10% (85 ms to 100 ms trip time for 100 ms setting in NFSL)			
Repeat accuracy		± 1%			
ON delay		50 ms ± 20 ms			
Reset time		< 100 ms			
Type of insulation		Reinforced			
Operating temperature		-15°C to +60°C			
Relative humidity		95% Rh (without condensation)			
Operating position		Any			
Maximum operating altitude		2000 m			
Mounting		Base/DIN rail			
Dimensions in mm (W x H x D)		22.5 x 83 x 100.5			
Degree of protection		IP40 for Enclosure, IP20 for Terminals			
Weight		120 gms (approx)			
Certifications					

Earth Leakage Relay

Earth Leakage Protection:

Earth Leakage relay is a microcontroller based device meant to measure leakage current and isolate the faulty circuit from the system. Leakage current is sensed through core balance current transformer. Trip occurs when Earth Leakage Current exceeds the Set value of trip current, for the trip time which is adjustable by means of a front mounted potentiometer. The Red LED "EL" indicates the presence of Earth Leakage.

CT Connection:

All conductors to be protected shall pass through the core balance current transformer. Current transformer secondary terminals should be connected to the product terminals by a shielded twisted two core wires. The shield to be connected to Y2 terminal. The CT wires should be placed adequately away from high current carrying conductors or source of strong magnetic field to avoid noise pickup. The Earth Leakage Relay also verifies CT connection. If CT winding is open, red LED "EL" blinks.

Earth Leakage Relay - Series CMR

Test/Reset: Press & hold Tact switch for 1s. Product will change its state from Healthy to Trip (Test) and vice versa (Reset).

Remote Test/Reset: For Remote Test Reset, connect an external push button switch between Y1 and Y2. For test sequence, press and hold the external push button switch for 1s.

Auto/Reset: In case of 17G715GF2 & 17G715KF2, product will reset after 15 min only for 4 attempts. Reset count is cleared after 1 hour of healthy condition or supply interruption or press of test /reset switch.

Connection Diagram (F2 series)

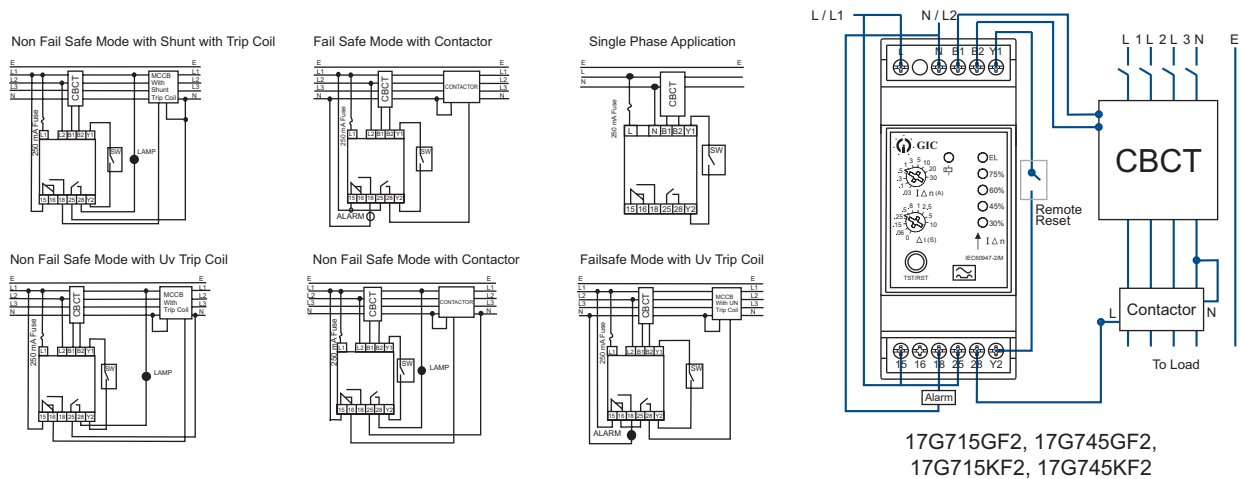

Functional Diagram

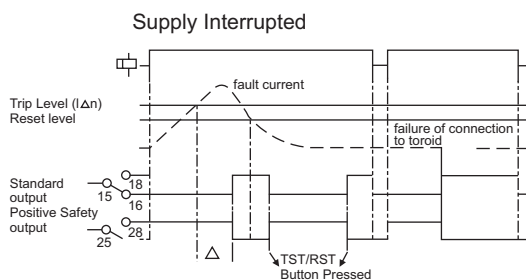

Overall Dimensions (F2 series)

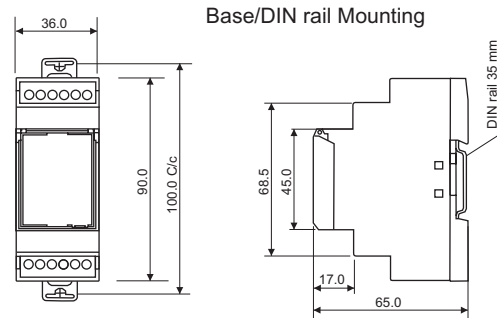

Earth Leakage Relay

Cat. No.		17G715GF2	17G715KF2	17G745GF2	17G745KF2
Supply voltage (φ)		110 - 240 V AC, 50/60 Hz		220 - 415 V AC, 50/60 Hz	
Supply variation		-20% to +20%			
Power consumption sensitivity		5 VA		10 VA	
LED Indication	Power ON	ON (Green LED)			
	EL / CT	ON (Red LED) Relay trip / Blinking (CT open)			
	Leakage current / TS	By Bar graph 30% (Green), 45% (Green), 60% (Yellow), and 75% (Red), Blink Test / Reset switch is pressed			
Overall leakage current $I_{\Delta n}$		30 mA - 30 A (in 10 steps)			
Contact rating		1 C/O + 1 NO; 5 A (Resistive) @ 240 V AC / 30 V DC			
Contact arrangement		1 NO SPST and 1C/O SPDT			
Utilization category	AC-15	Ue Rated voltage: 120 / 240 V, Ie Rated current: 3.0 / 1.5 A			
	DC-13	Ue Rated voltage: 125 / 250 V, Ie Rated current: 0.22 / 0.10 A			
Mechanical life		1 x 10 ⁷ operations			
Electrical life		1 x 10 ⁵ operations			
Contact material		Ag Alloy			
Reset		Manual reset	Auto reset	Manual reset	Auto reset
No. of auto resets		-	4	-	4
Clear auto reset		After 1 hour of healthy condition or supply interruption			
Test / Reset		Local and Remote (Non potential free contacts) (Upto 10 m)			
Δ Settings (s)		0.040 - 0.06 - 0.15 - 0.25 - 0.5 - 0.8 - 1 - 2.5 - 5 - 10			
Reset enable		Below 50% on current threshold set by potentiometer and in presence of CBCT			
Reset time		<1 s			
Threshold ($I_{\Delta n}$)		0.03 - 0.1 - 0.3 - 0.5 - 1 - 3 - 5 - 10 - 20 - 30			
Type class		'A' True RMS measurement (as per IEC 60947-2 Annex M)			
Max. crest factor		5 (for 30 mA to 30 A)			
Setting accuracy		-20% (Including CBCT accuracy)			
Repeat accuracy		±2%			
Operating temperature		-15°C to +60°C			
Relative humidity		95% Rh (without condensation)			
Max. operating altitude		2000 m			
Degree of protection		IP20 for Terminals, IP40 for Enclosure			
Operating position		Any			
Mounting		Base/DIN rail			
Dimensions in mm (W x H x D)		36 x 90 x 65			
CBCT Burden		Should support 50, 2 W, to give 1 V output at 30 A			
Dimensions (with Enclosure in mm W x H x D) ID	CBCT1	37 x 91 x 71, ID 38 mm (17H7NNHN3)		Turns Ratio-1 500:1 Linearity: ±2% over the range of 30 mA to 30 A Characteristics: Type A as per IEC 60947-2.	
	CBCT2	37 x 117 x 97, ID 57 mm (17H7NNIN3)			
	CBCT3	37 x 155 x 132, ID 92 mm (17H7NNJN3)			
Weight (Unpacked)		150 gms (approx)			
Certifications		CE 			

If the trip time is set at '0' sec, then for 5 $I_{\Delta n}$ & 10 $I_{\Delta n}$, the tripping time will be </- 40 ms for all current ranges.

Hour Meter Series HM 36

- Robust design
- Frequency independent for AC applications
- High degree of accuracy
- Wide supply voltage working models 4-30 V AC/DC, 10-80 V DC and 90-264 V AC
- Wide temperature range from -40 to 85°C
- Totally sealed from dust and moisture



Digital Counter

- Wide supply voltage
- Large 6 digit display, easy to read
- Exceptional reliability due to non volatile memory (EEPROM) which can retain the data for 100 years
- Available in 3 different shaped Bezels
- Low power consumption
- Electrical reset and enable

Description	Cat. No.												
Digital Hour Meter / Digital Counter (Resettable)	Z□□FB□												
<table border="0"> <tr> <td>Voltage</td> <td>1 Hour Meter</td> <td>Bezel</td> </tr> <tr> <td>H 10 - 80 V DC</td> <td>2 Counter</td> <td>A Round</td> </tr> <tr> <td>7 85 - 265 V AC</td> <td></td> <td>B 24 x 48</td> </tr> <tr> <td>J 12 - 48 V AC/DC</td> <td></td> <td>C Screw Mount</td> </tr> </table>	Voltage	1 Hour Meter	Bezel	H 10 - 80 V DC	2 Counter	A Round	7 85 - 265 V AC		B 24 x 48	J 12 - 48 V AC/DC		C Screw Mount	
Voltage	1 Hour Meter	Bezel											
H 10 - 80 V DC	2 Counter	A Round											
7 85 - 265 V AC		B 24 x 48											
J 12 - 48 V AC/DC		C Screw Mount											

Connection Diagram

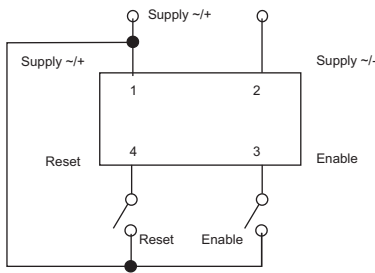

Terminal Description

- Pin 1: Supply (~ / +)
- Pin 2: Supply (~ / -)
- Pin 3: Enable
- Pin 4: Reset

HM 36 Series

For: DC Series

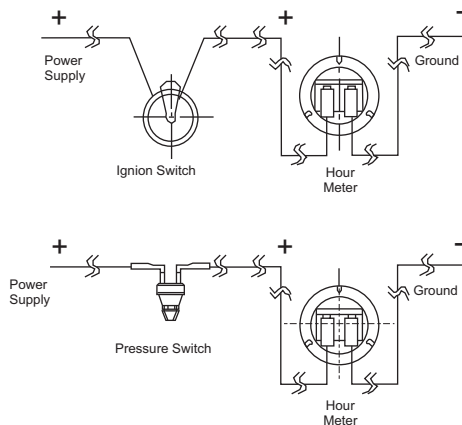

For: AC Series

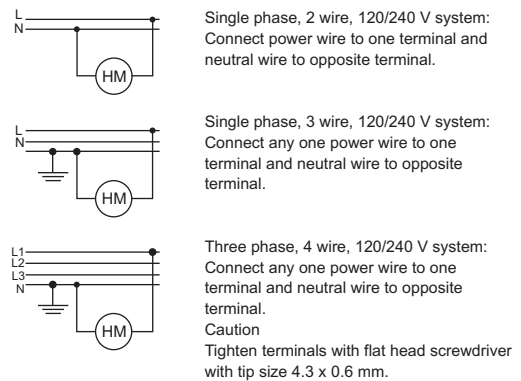

HM36

Description	Cat. No.
90 - 240 V AC, Rectangular bezel	LA21F1
90 - 240 V AC, Rectangular 2 holes bezel	LA22F2
90 - 240 V AC, Round bezel	LA23F1
90 - 240 V AC, Round 3 holes bezel	LA24F1
90 - 240 V AC, Square mount bezel	LA25F1
90 - 240 V AC, Cup mount bezel	LA26F1
90 - 240 V AC, Stirrup mount bezel	LA27F1
10 - 80 V DC, Rectangular bezel	LD11F1
10 - 80 V DC, Rectangular 2 holes bezel	LD2F1
10 - 80 V DC, Round bezel	LD3F1
10 - 80 V DC, Round 3 holes bezel	LD4F1
10 - 80 V DC, Cup mount bezel	LD5F1
10 - 80 V DC, Stirrup mount bezel	LD6F1
10 - 80 V DC, Square mount bezel	LD7F1
4 - 30 V AC/DC, Rectangular bezel	LC1F1
4 - 30 V AC/DC, Rectangular 2 holes bezel	LC2F1
4 - 30 V AC/DC, Round bezel	LC3F1
4 - 30 V AC/DC, Round 3 holes bezel	LC4F1
4 - 30 V AC/DC, Cup mount bezel	LC5F1
4 - 30 V AC/DC, Stirrup mount bezel	LC6F1
4 - 30 V AC/DC, Square mount bezel	LC7F1

Views of Different Bezels



Rectangular Bezel



Rectangular 2 holes Bezel



Round Bezel



Round 3 holes Bezel



Cup Mount Bezel



Stirrup Mount Bezel

Counter

Round bezel

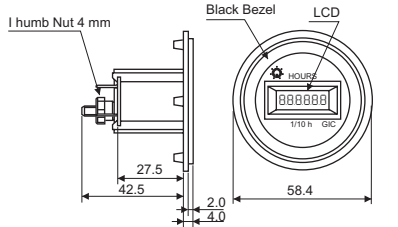

Recommended Panel Cutout:
37.0 (+0.5) mm x 24.6 (+0.5) mm

24x48 bezel

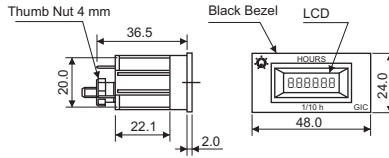

Recommended Panel Cutout:
45.5 (+0.5) mm x 23.0 (+0.5) mm

Screw Mount Bezel

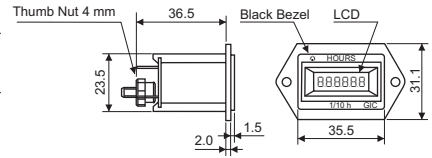

Recommended Panel Cutout:
37.0 (+0.5) mm x 24.6 (+0.5) mm

HM 36

View of Different Bezels :

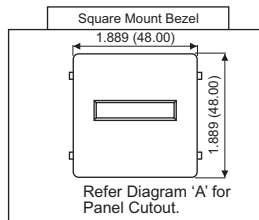
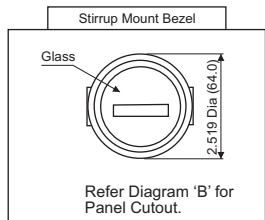
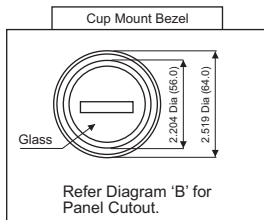
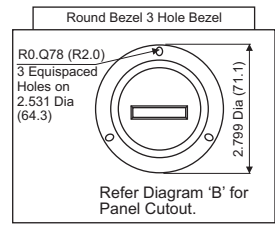
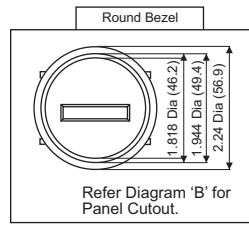
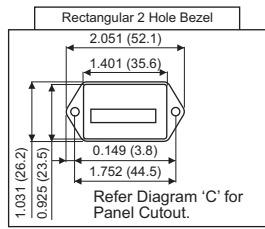
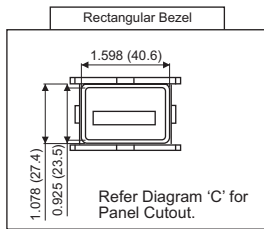

Panel Cutout

Diagram A

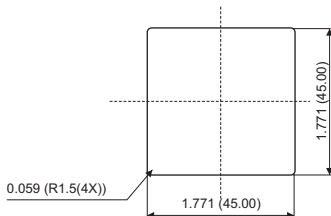

Diagram B

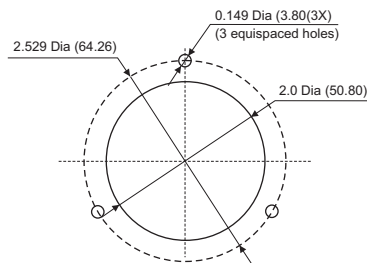
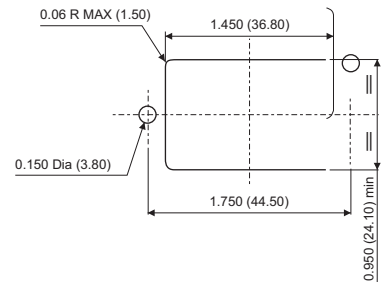

Diagram C



Max. Panel Thickness : 0.029 (0.76) to 0.401 (10.20)
 Panel cutout Dimensions - Tolerance: ± 0.010 (0.30)
 All dimensions are in Inches, values in parenthesis are in mm

Digital Hour Meter

Cat. No.	Z72FBX	ZJ2FBX	ZH2FBX
Supply voltage	85-265 V AC 50/60 Hz	10-55 VAC/DC 50/60 Hz	10-80 V DC
Rating	0.8 VA	0.4 watt	0.6 watt
Range	999999 Counts		
Resolution	1 Count		
Accuracy	±1 Count		
Counting frequency	10 Hz	30 Hz	
Mounting	Flush / Panel mounting		
Temperature limits	Operating: -10°C to +50°C		
Degree of protection	IP54 (for front side only)		
Terminals	1, 2 : Input supply, 3 : Enable, 4 : Reset		
Weight	with Round bezel - 35 g (approx)		
	with 24 x 48 bezel - 29 g (approx)		
	with Screw mount bezel - 31 g (approx)		

Hour Meter Series HM 36

Cat. No.	LA25F1	LD15F1	LC36F1
Supply voltage	90-264 V AC	10-80 V AC	4-30 V AC/DC
Frequency	50/60 Hz	NA	50/60 Hz
Over voltage and reverse polarity protection	NA	Protected for 2 times battery voltage and / or Reverse polarity	Not applicable to AC and 48 V for DC application
Power consumption	0.5 VA	0.25 VA	1 VA
Bezel	Square mount	Cup mount	Stirrup mount
Read out	99999.9		
Least count	1/10 h		
Accuracy	±0.02% over entire range		
Weight	55 g (approx)		
Termination	1/4" (6.3) Spade terminal		
Degree of protection	IP66		

Timer: Micon 225

ON Delay	Multi Function	Asymmetric ON-OFF	Signal based Multi Function
----------	----------------	-------------------	-----------------------------

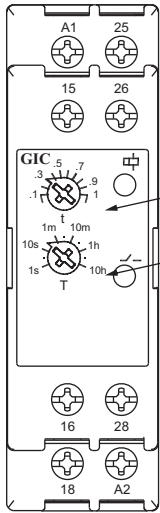

2A0DT5,
29ODT5

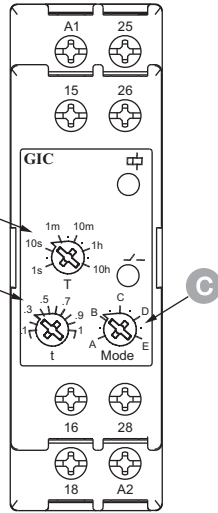

2A5DT5, 2B5DT5,
2A6DT6, 2B6DT6

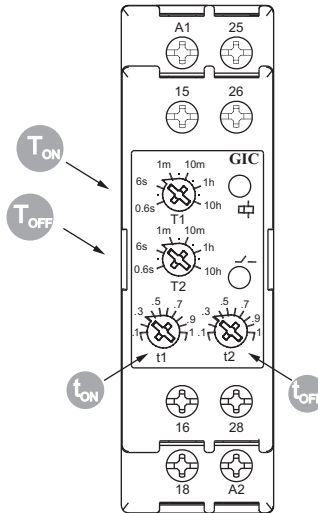

2AADT5,
25ADT5

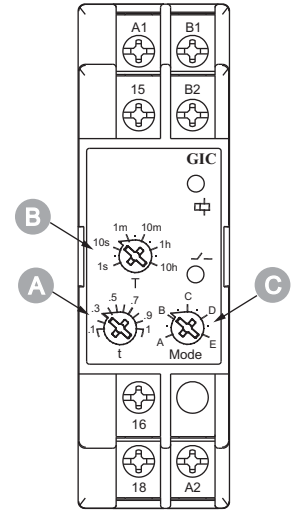

2ANDT0

Brownout Timer	Star Delta	True OFF Delay	Motor Restart Relay
----------------	------------	----------------	---------------------

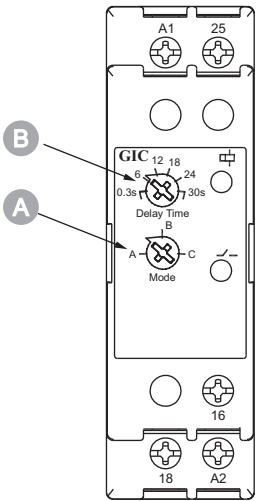

23UDT0,
27UDT0

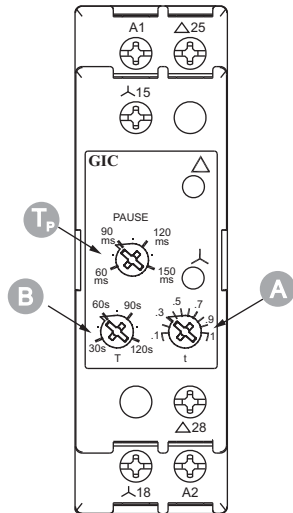

2ASDT0,
2BSDT0

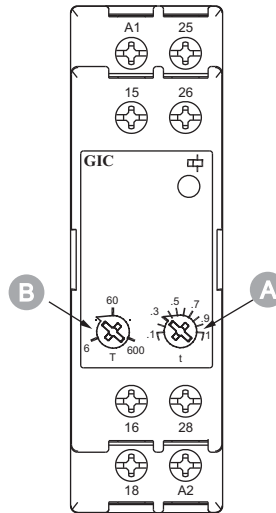

23GDT0

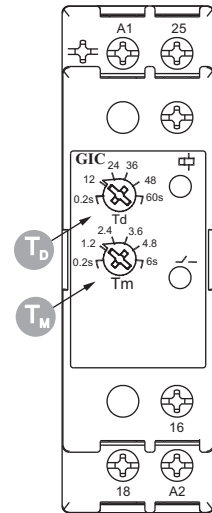

22LDT0,
23LDT0

- A** Main Time Range Knob (T) **B** Multiplication Factor Knob (t) of T **C** Mode Selection Knob
- T_{ON}** ON Time Range Knob (T1) **T_{OFF}** OFF Time Range Knob (T2) **t_{ON}** ON Time Multiplication Factor Knob, (t1) of T1
- t_{OFF}** OFF Time Multiplication Factor Knob (t2) of T2 **T_D** Delay Time Setting Knob **T_M** Memory Time Setting Knob,
- T_P** Pause Time Knob

Timer: Micon 175

ON Delay	Multi - Function	Asymmetric ON-OFF	Star Delta	Brownout Timer
----------	------------------	-------------------	------------	----------------

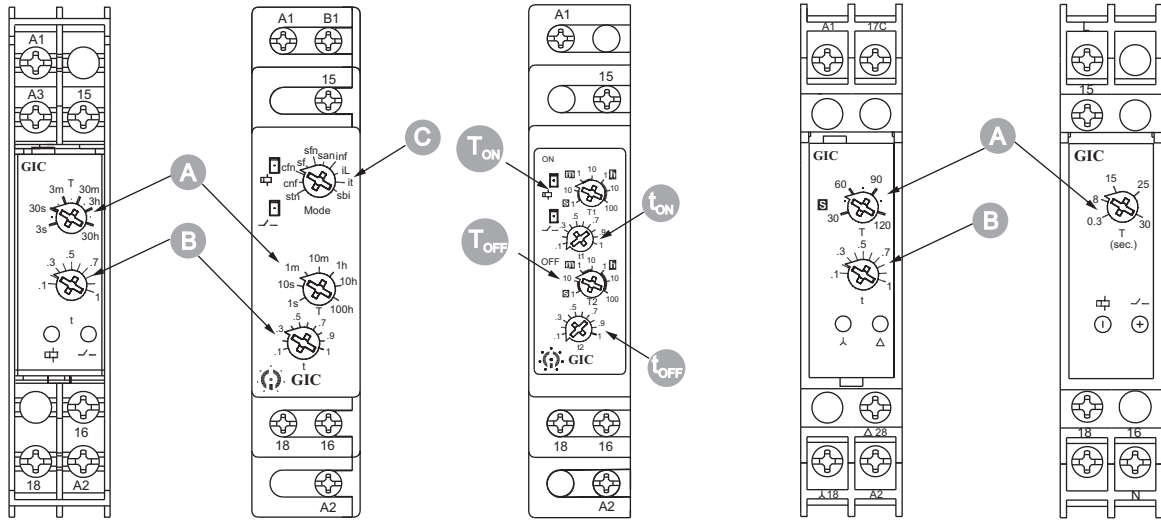

12ODT4, 11ODT4,
15ODT4

1CMDT0

1CJDT0

12SDT0

17UDT0,
17UDT1

- A** Main Time Range Knob (t)
- B** Multiplication Factor Knob (t) of T
- C** Mode Selection Knob
- T_{ON}** ON Time Range Knob (T1)
- T_{OFF}** OFF Time Range Knob (T2)
- t_{ON}** ON Time Multiplication Factor Knob, (t1) of T1
- t_{OFF}** OFF Time Multiplication Factor Knob (t2) of T2

Supply Monitoring: SM 175

Phase Sequence Phase Loss Relay	Phase & Voltage Monitoring Relay	Phase Sequence Unbalance Relay
------------------------------------	----------------------------------	-----------------------------------

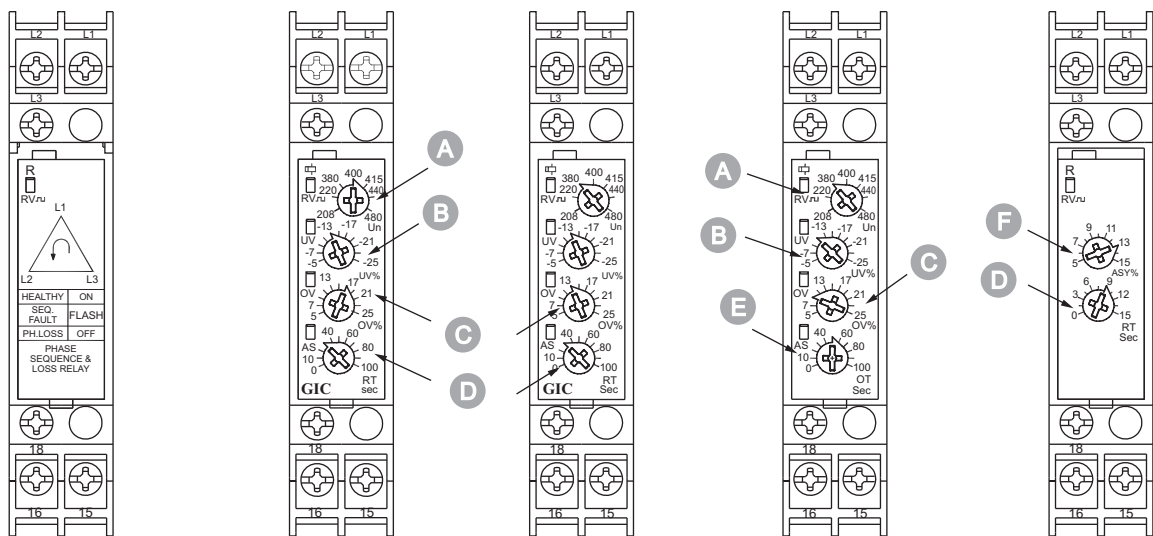

MC21D5,
MK21D5

MG21DF

MD21DF

MG21DH

MA21DN

- A** Reference Voltage Knob (Un)
- B** Under Voltage Knob (UV)
- C** Over Voltage Knob (OV)
- D** Release Time Knob (RT)
- E** Operate Time Knob (OT)
- F** Asymmetry Seeking Knob (Asy)

Supply Monitoring: SM 500

Phase & Voltage Control

Neutral Loss Protection

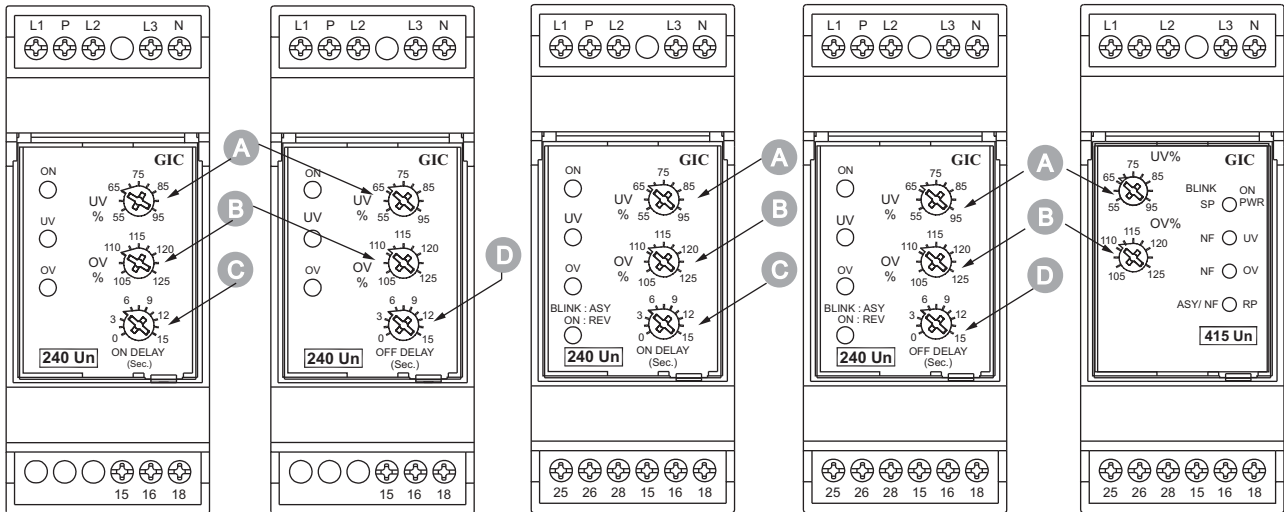

MD71BH,
MD71B9

MD71BF

MG73BH,
MG73B9

MG73BF

MAC04D0100

- A** Under Voltage Knob (UV)
- B** Over Voltage Knob (OV)
- C** ON Delay Time Knob
- D** OFF Delay Time Knob

Supply Monitoring: SM 501

Phase & Voltage Control

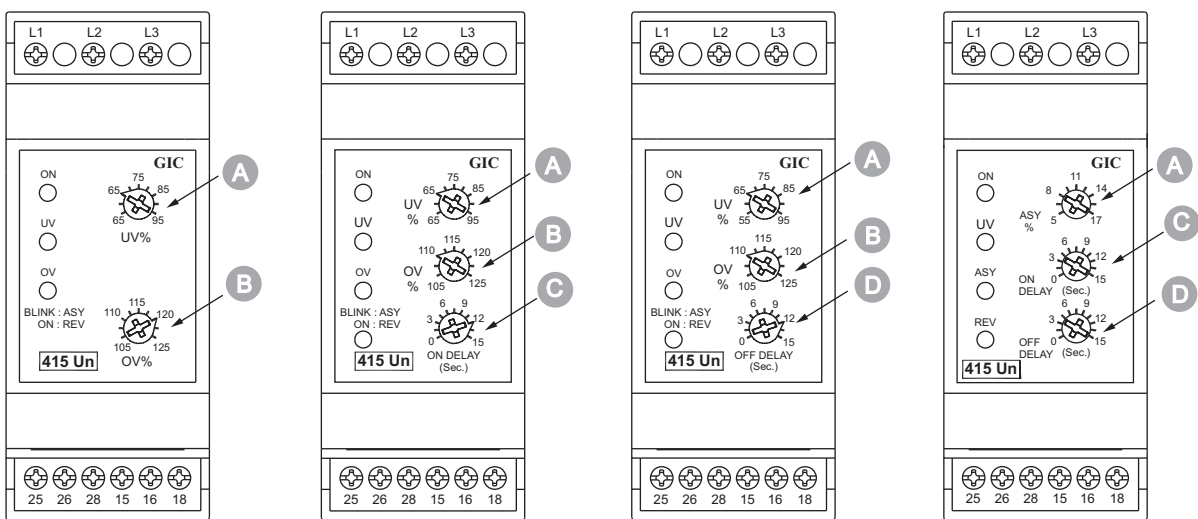

MG53BI

MG53BH

MG53BF, MG53BO

MB53BM

- A** Under Voltage Knob (UV)
- B** Operate Time Knob (OV)
- C** ON Delay Time Knob
- D** OFF Delay Time Knob

Supply Monitoring: SM 301

Single Phasing Preventor

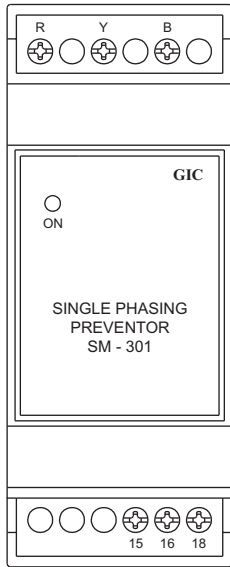

MA51BC

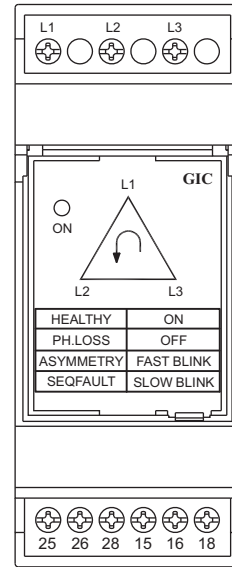

MC21B5

Supply Monitoring: Earth Leakage Relay

Earth Leakage Relay

ELR (22.5 mm series)

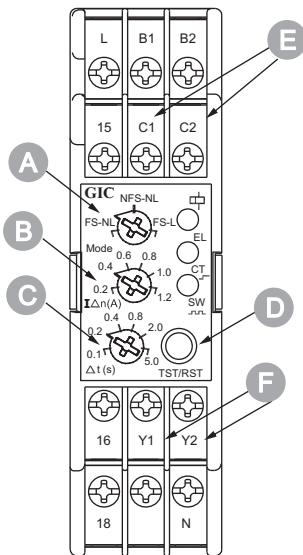

17G514FF1, 17G614FF1,

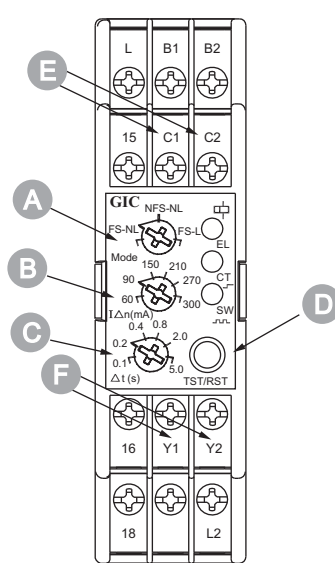

17G544FF1, 17G644FF1

ELR (35 mm series)

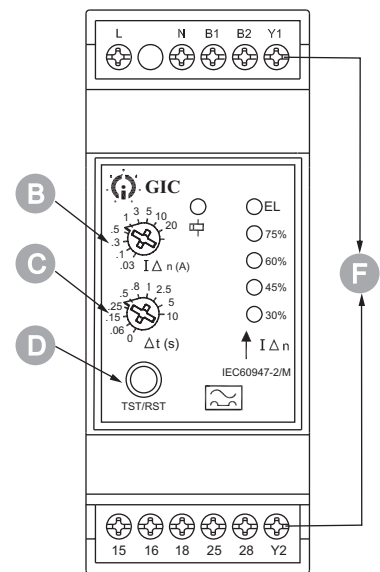

17G715GF2, 17G715KF2
17G745GF2, 17G745KF2

- A** Mode Selection Knob
- B** Earth Leakage Current Selection Knob
- C** Trip Time Selection Knob
- D** Test Reset Switch
- E** Test Point
- F** External Remote Reset

Supply Monitoring: Current Monitoring Relay

Single Phase

Three Phase

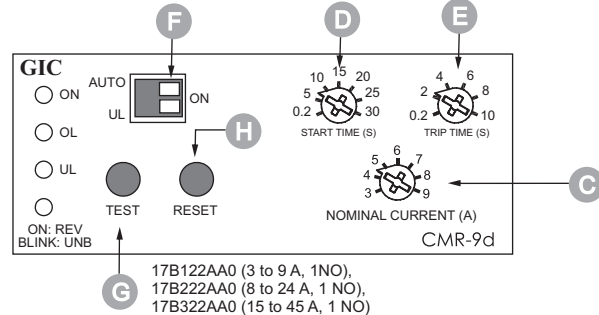
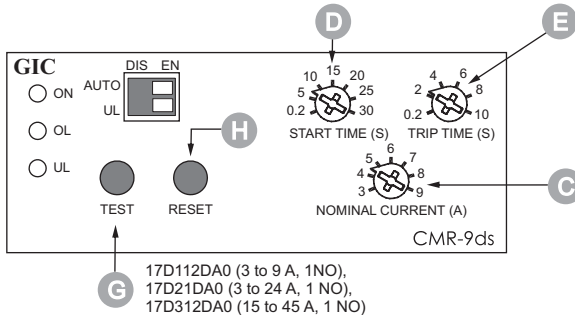
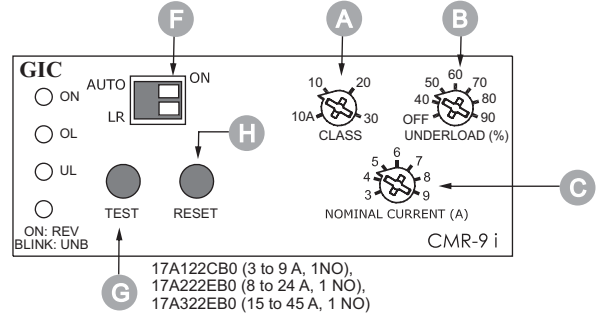
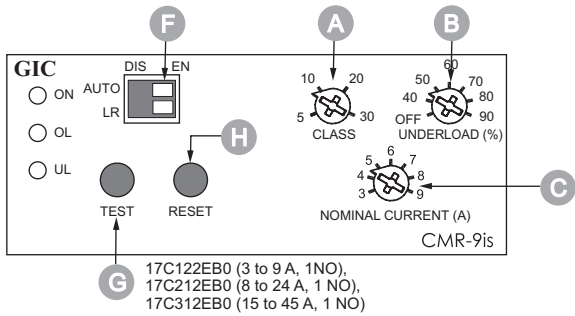

Note:
3 to 9 A range available in steps of 3, 4, 5, 6, 7, 8 and 9 A
8 to 24 A range available in steps of 8, 12, 16, 20 and 24 A
15 to 45 A range available in steps of 15, 21, 27, 33, 39 and 45 A

- A Class Selection Knob
- B % of Underload Selection Knob
- C Nominal Current Knob (A)
- D Start Time Knob (S)
- E Trip Time Knob (S)
- F Class Selection Switch
- G Test Switch
- H Reset Switch

Supply Monitoring: PTC Thermistor Relay Series

Thermistor Relay

Thermistor Relay (SPPR)

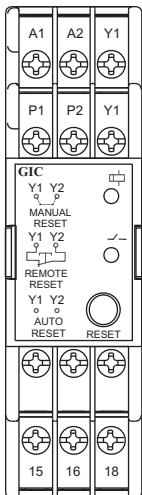

MJ81BK,
MJ91BK

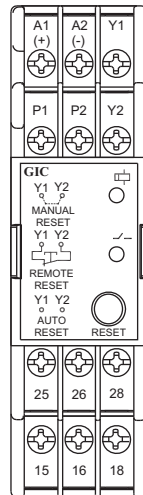

MJA3BK,

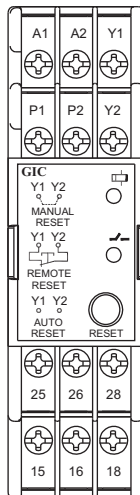

MJ93BK,
MJ83BK

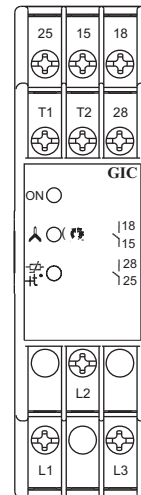

ML64BS,
MLD4BS

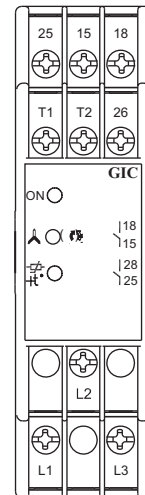

ML67BS,
MLD7BS

Supply Monitoring: Frequency Monitoring Relay

Over Frequency Monitoring Relay Under/Over Frequency Monitoring Relay

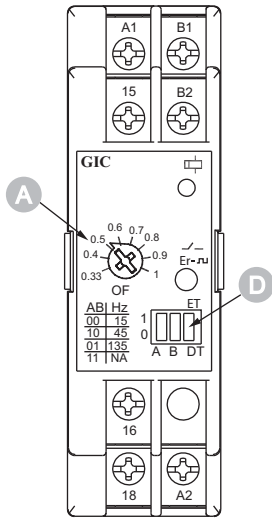

MI81BJ, MI91BJ

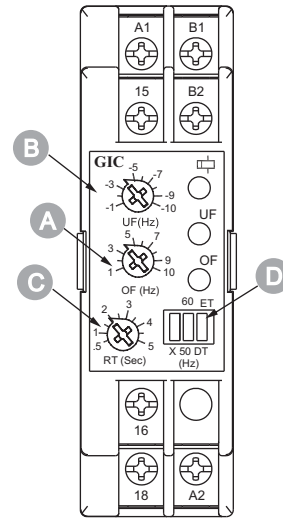

MI81BL, MI91BL

- A** Over Frequency Knob (OF) **B** Under Frequency Knob (UF)
- C** Release Time Knob (RT)
- D** Enable to Trip (ET), Disable to Trip (DT)



Modular Remote Control Units

Remote control units play a crucial role on factory shop floor for operational safety and reliability. Reliable push buttons and indicators from our partners ESBEE, have been trusted by users across industries over the past 3 decades.

ESBEE's product range includes:

New Gen Next Range of Products

- Gen Next Actuators & Contact Blocks
- Gen Next Push Button Station
- Gen Next LED Indicators
 - 16 Ø mm & 22.5 Ø mm
- Gen Next *e*ntegral Actuators

Standard Range of Products

- Standard Actuators & Contact Blocks
- Standard Push Button Stations
- Accessories

The new ranges of Gen Next series products are compact in size and aesthetically appealing.

16 mm Gen Next LED Indicators have sleek and integral design with special fire retardant plastic. They provide uniform and bright illumination with operating life of more than 0.1 million burning hours.

Patented *e*ntegral actuator is a ready to use solution for OEM and Panel builders that provides IP67 protection with shroud. It has isolated terminals for NO+NC applications.



Illuminated actuators with LED have snap fit for ease in assembly with low power consumption of 0.6W max.

Push button stations provide round ergonomic enclosure with good aesthetics that occupies less space. They are robust, easy to grip, assemble and operate. It is available in standard configuration of actuators and LED indicators.

Gen Next Series



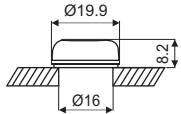

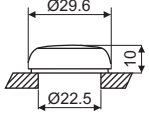
Gen Next LED Indicator

- Surface Mounted Device LED technology
- Low Power consumption < 0.6 W
- LVGP & Surge protection



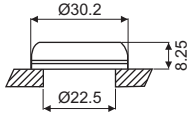

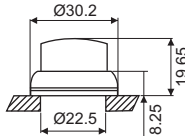

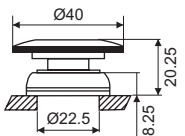



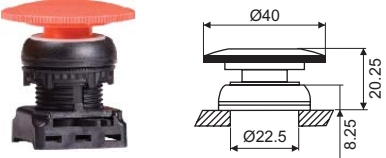
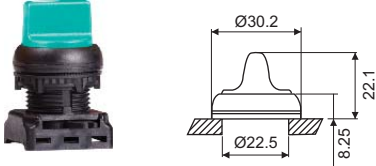





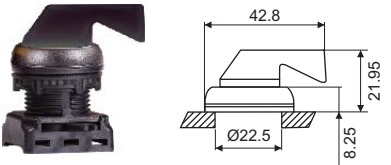

	Description	Cat. No.	Colour (4 th Digit)	Voltage (5 th , 6 th , 7 th & 8 th Digit)
 	Gen Next LED Indicator 16 mm	SIL□□□□□	R-Red G-Green Y-Yellow A-Amber B-Blue W-White	012C - 12 V AC/DC 024C - 24 V AC/DC 048C - 48 V AC/DC 064C - 64 V AC/DC 110C - 110 V AC/DC 240A - 240 V AC
 	Gen Next LED Indicator 22.5 mm	EIL□□□□□	R-Red G-Green Y-Yellow A-Amber B-Blue W-White	012C - 12 V AC/DC 024C - 24 V AC/DC 048C - 48 V AC/DC 064C - 64 V AC/DC 110A - 110 V AC 110D - 110 V DC 240A - 240 V AC 220D - 220 V DC 415A - 415 V AC

Gen Next Push Button & Selector Actuators Ø 22.5 mm

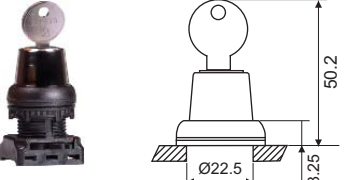
- Snap Mounting with compact contact blocks (EC1C & EC2C)
- Max 3 row x 3 column stackable contact blocks

	Description	Cat. No.	Colour (4 th Digit)
 	Flush Head	EMN□FD1	R-Red G-Green C-Black Y-Yellow W-White B-Blue A-Amber F-Gray
 	Projecting Head 'Push Function'	EMN□PD1	R-Red G-Green C-Black Y-Yellow W-White B-Blue A-Amber F-Gray
 	Mushroom Head 'Push - Turn Function'	EMN□MH1	R-Red G-Green C-Black Y-Yellow

Gen Next Push Button & Selector Actuators Ø 22.5 mm

	Description	Cat. No.	Colour (4 th Digit)
	Mushroom Head 'Push - Function'	EMN□MD1	R-Red G-Green C-Black Y-Yellow
	Symmetric Head	<p>2 Position</p> <p> Non Spring Return EMN□SK1</p> <p> Spring Return EMN□SI1</p> <p>3 Position</p> <p> Non Spring Return EMN□SL1</p> <p> Spring Return EMN□SJ1</p> <p> Spring Return L. H. EMN□SM1</p> <p> Spring Return R. H. EMN□SN1</p>	R-Red G-Green C-Black W-White
	Lever Head	<p>2 Position</p> <p> Non Spring Return EMN□LK1</p> <p> Spring Return EMN□LI1</p> <p>3 Position</p> <p> Non Spring Return EMN□LL1</p> <p> Spring Return EMN□LJ1</p> <p> Spring Return L. H. EMN□LM1</p> <p> Spring Return R. H. EMN□LN1</p>	R-Red W-White C-Black
	Lock & Key Rotary Type	<p>2 Position</p> <p> Non Spring Return EMN□KK1</p> <p> Spring Return EMN□KI1</p> <p>3 Position</p> <p> Non Spring Return EMN□KL1</p> <p> Spring Return EMN□KJ1</p> <p> Spring Return L. H. EMN□KM1</p> <p> Spring Return R. H. EMN□KN1</p>	C-Black





Note :

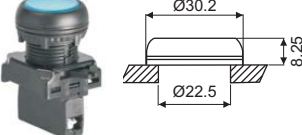
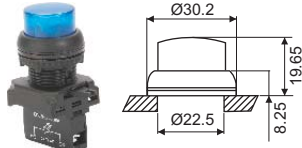
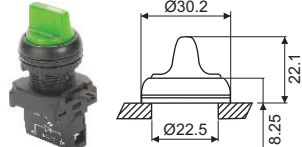

- Actuators & Selector Actuators with black ABS collar are offered as Standard
- Actuators (except Mushroom Head Push - Pull Actuators) are also available with chrome plated ABS & Brass collar
 - For Chrome plated ABS Collar replace 7th digit 1 by 3 **eg. : EMNPD3**
 - For Brass Collar replace 7th digit 1 by 2 **eg. : EMNPD2**
- For Non-Illuminated Actuator / Selector Actuator at least 1 NO or NC Block required to make a complete Assembly
eg. EMNRFD1 + EC1C makes complete assembly of flush head actuator with 1 NO Block

Note * - In 2 position selector actuator, for operating style  replace 6th digit from K to R and for operating style , replace 6th digit from K to T



Gen Next Illuminated Push Button Actuators

- Snap Mounting with compact contact blocks (EC1C & EC2C)

	Description	Cat. No.	Colour (8 th Digit)	Voltage (9 th , 10 th , 11 th & 12 th Digit)
	Flush Head	EG03FDL□□□□□	R-Red G-Green Y-Yellow A-Amber	012C - 12 V AC/DC 024C - 24 V AC/DC 030C - 30 V AC/DC 048C - 48 V AC/DC 064C - 64 V AC/DC 110A - 110 V AC 110D - 110 V DC 240A - 240 V AC 220D - 220 V DC
			B-Blue W-White	
	Projecting Head (Push Function)	EG03PDL□□□□□	R-Red G-Green Y-Yellow A-Amber	012C - 12 V AC/DC 024C - 24 V AC/DC 030C - 30 V AC/DC 048C - 48 V AC/DC 064C - 64 V AC/DC 110A - 110 V AC 110D - 110 V DC 240A - 240 V AC 220D - 220 V DC
			B-Blue W-White	
	Selector Actuator with LED holder	2 Position Non Spring Return EG03SKL□□□□□ 	R-Red G-Green Y-Yellow A-Amber B-Blue W-White	012C - 12 V AC/DC 024C - 24 V AC/DC 030C - 30 V AC/DC 048C - 48 V AC/DC 064C - 64 V AC/DC 110A - 110 V AC 110D - 110 V DC 240A - 240 V AC 220D - 220 V DC
		Spring Return EG03SIL□□□□□ 		
		3 Position Non Spring Return EG03SLL□□□□□ 		
		Spring Return EG03SJL□□□□□ 		

Note* : 1) In 2 position selector actuator, for operating style  replace 6th digit from K to R and for operating style  replace 6th digit from K to T.
2) Assembly comes with LED holder. Please order contact block EC1C and EC2C separately.











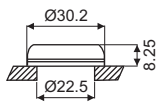

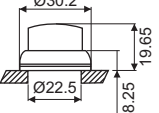

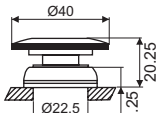

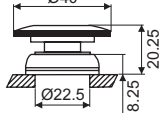

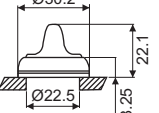



Gen Next Modular Contact Blocks

	Description	Cat. No.	Colour (8 th Digit)	Voltage (9 th , 10 th , 11 th & 12 th Digit)
	'NO' Block	EC1C	-	-
	'NC' Block	EC2C	-	-
	LED Holder for Gen Next series	EG08HOL□□□□□	R-Red G-Green Y-Yellow A-Amber	012C - 12 V AC/DC 024C - 24 V AC/DC 048C - 48 V AC/DC 064C - 64 V AC/DC 110A - 110 V AC 110D - 110 V DC 240A - 240 V AC 220D - 220 V DC
			B-Blue W-White	

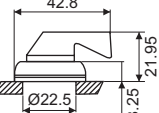





Note : Gen Next Modular Contact Blocks (EC1C and EC2C) can be used only with Gen Next Push Button Actuator



Gen Next Integral Actuator

- With inbuilt contact arrangement
- Contact rating 6 A @ 240 AC

	Description	Cat. No.	Contact Configuration (3rd Digit)	Colour (4 th Digit)
 	Flush Head	EE□□FD1	1 - 1 NO 2 - 1 NC	R-Red G-Green Y-Yellow W-White B-Blue A-Amber C-Black
			3 - 1 NO + 1 NC 4 - 2 NO 5 - 2 NC	
 	Projecting Head Push Function	EE□□PD1	1 - 1 NO 2 - 1 NC	R-Red G-Green Y-Yellow W-White B-Blue A-Amber C-Black
			3 - 1 NO + 1 NC 4 - 2 NO 5 - 2 NC	
 	Mushroom Head Push - Turn	EE□□MH1	1 - 1 NO 2 - 1 NC	R-Red G-Green Y-Yellow C-Black
			3 - 1 NO + 1 NC 4 - 2 NO 5 - 2 NC	
 	Mushroom Head Push - Function	EE□□MD1	1 - 1 NO 2 - 1 NC	R-Red G-Green Y-Yellow C-Black
			3 - 1 NO + 1 NC 4 - 2 NO 5 - 2 NC	
 	Symmetric Head Actuator	2 Position  Non Spring Return EE□□SK1	1 - 1 NO 2 - 1 NC 3 - 1 NO + 1 NC (Left NO) 4 - 2 NO 5 - 2 NC 6 - 1 NO + 1 NC (Right NO)	R-Red G-Green W-White C-Black
		 Spring Return EE□□SI1		
		3 Position  Non Spring Return EE□□SL1		
		 Spring Return EE□□SJ1		
		 Spring Return L. H. EE□□SM1		
		 Spring Return R. H. EE□□SN1		
 	Lever Head	2 Position  Non Spring Return EE□□LK1	1 - 1 NO 2 - 1 NC 3 - 1 NO + 1 NC (Left NO) 4 - 2 NO 5 - 2 NC 6 - 1 NO + 1 NC (Right NO)	R-Red G-Green W-White C-Black
		 Spring Return EE□□LI1		
		3 Position  Non Spring Return EE□□LL1		
		 Spring Return EE□□LJ1		
		 Spring Return L. H. EE□□LM1		
		 Spring Return R. H. EE□□LN1		

Gen Next Integral Actuator

	Description	Cat. No.	Contact Configuration (3rd Digit)	Colour (4 th Digit)
	Lock & Key Rotary Type	2 Position		1 - 1 NO 2 - 1 NC
 Non Spring Return EE□□KK1		 Spring Return EE□□KI1	3 - 1 NO + 1 NC (Left NO) 4 - 2 NO 5 - 2 NC 6 - 1 NO + 1 NC (Right NO)	
3 Position				
 Non Spring Return EE□□KL1		 Spring Return EE□□KJ1	3 - 1 NO + 1 NC (Left NO) 4 - 2 NO 5 - 2 NC 6 - 1 NO + 1 NC (Right NO)	
 Spring Return L. H. EE□□KM1				
 Spring Return R. H. EE□□KN1				

Note * - In 2 position selector actuator, for operating style  replace 6th digit from K to R and for operating style  replace 6th digit from K to T





Panel Mounted Buzzer Ø 22.5 mm

- IP20 protection
- 80dB at 1 meter









	Description	Electrical Rating	Cat. No.	
			Round Type	Square Type
22.5 mm Panel Mounted Buzzer Black colour		240 V AC	EG15R00C240A	EG15S00C240A
		110 V AC	EG15R00C110A	EG15S00C110A
		64 V AC/DC	EG15R00C064C	EG15S00C064C
		48 V AC/DC	EG15R00C048C	EG15S00C048C
		30 V AC/DC	EG15R00C030C	EG15S00C030C
		24 V AC/DC	EG15R00C024C	EG15S00C024C
		12 V AC/DC	EG15R00C012C	EG15S00C012C

Gen Next Push Button Stations

- Dimension
- Single Station : 65 x 55 x 33 mm
 - Two Station : 100 x 55 x 53 mm
 - Three Station : 134 x 55 x 53 mm
 - Eight Station : 305 x 55 x 53 mm

	Description	Cat. No.
	Flush Head Actuator - Red with Legend - STOP Contact - 1 'NC'	EP1FAC01
	Flush Head Actuator - Green with Legend - START Contact - 1 'NO'	EP1FAB02
	Two Position Symmetric Head Selector Switch - Black with Legend - OFF / ON Contact - 1 'NO'	EP1FAF08
	Two Position Lock & Key Rotary Switch with Legend - OFF / ON Contact - 1 'NO'	EP1FAF12
	Mushroom Head Actuator 'Push Function' with Legend - STOP Contact - 1 'NC' for Stop	EP1FAC03

Gen Next Push Button Stations

	Description	Cat. No.
	Mushroom Head Actuator 'Push Turn Type' with Legend - STOP Contact - 1 'NC' for Stop	EP1FAC05
	Flush Head Actuator - Green with Legend - START Contact - 1 'NO' (Station One)	EP2FAH0201
	Flush Head Actuator - Red with Legend - STOP Contact - 1 'NC'	
	Flush Head Actuator - Green with Legend - START Contact - 1 'NO' (Station One)	EP2FAH0205
	Mushroom Head Actuator 'Push Turn Type' with Legend - STOP Contact - 1 'NC' (Station Two)	
	LED Indicator 240 V AC - Red (Station One)	EP3FAUI1X0201
	Flush Head Actuator - Green with Legend - START Contact - 1 'NO' (Station Two)	
	Flush Head Actuator - Red with Legend - STOP Contact - 1 'NC' (Station Three)	
	Flush Head Actuator - Green with Legend - FORWARD Contact - 1 'NO' (Station Two)	EP3FAR020102
	Flush Head Actuator - Red with Legend - STOP Contact - 1 'NC' (Station Two)	
	Flush Head Actuator - Green with Legend - REVERSE Contact - 1 'NO' (Station Three)	
	Flush Head Actuator - Green with Legend - UP Contact - 1 'NO' (Station Two)	EP3FAS020102
	Flush Head Actuator - Red with Legend - STOP Contact - 1 'NC' (Station Two)	
	Flush Head Actuator - Green with Legend - DOWN Contact - 1 'NO' (Station Three)	
	All 7 Flush Head Actuators with NO Contact & Mushroom Head Push Turn	EP8F02
	8 Way push button pendant with hanging provision	EP8F04
	Single Station Enclosure Box without Actuator	EP1FAA
	Two Station Enclosure Box without Actuator	EP2FAA
	Three Station Enclosure Box without Actuator	EP3FAA
	Eight Station Enclosure Box without Actuator	EP8FAA

- Note: 1. All Gen next push button stations contains integral Actuators.
 2. Only entegral actuators can be used for converting Gen next enclosure boxes into Gen Next push button station.
 3. For any other combination of actuators/indicators in push button stations please contact nearest branch office.
 4. EP8F04 is available in single speed for crane application.

Standard Series

Standard Indicators

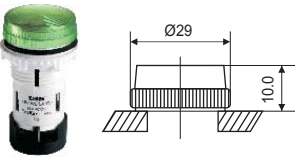
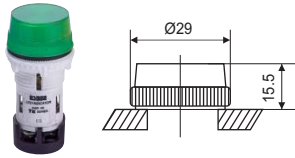
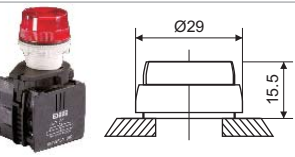
	Description	Cat. No.	Colour (4 th Digit)	Voltage (5 th & 6 th Digit)
	LED Indicator	TT0□□□	1-Red 2-Green 4-Yellow 5-White/Opal 6-Blue 7-Orange	X1 - 240 V AC X2 - 220 V DC W1 - 110 V AC W2 - 110 V DC Q1 - 63.5 V AC/DC V1 - 48 V AC/DC U1 - 24 V AC/DC T1 - 12 V AC/DC S1 - 6 V AC/DC
	Compact Integral Indicator with Resistor & Diode	TM0□X1	1-Red 2-Green 4-Yellow 5-White/Opal 6-Blue 7-Orange 8-Colorless	X1 - 240 V AC
	Universal Voltage LED Indicator	TP0□Z1 TP0□Z2	1-Red 2-Green 4-Yellow 5-White 6-Blue 7-Orange	Z1 - 40 V to 240 V AC/DC Z2 - 24 V to 240 V AC/DC

TEEKAY Series

- Pre assembled actuators with 1 NO (HC61A2) or 1 NC (HC61B2) contact blocks with single row clip

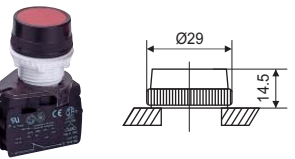
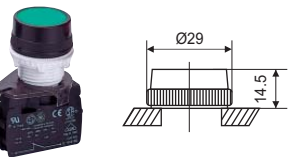
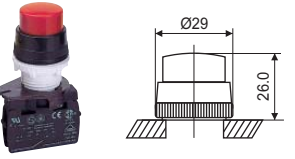
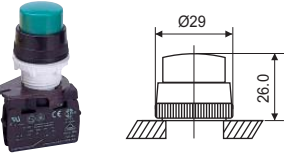
	Description	Cat. No.	Colour (4 th Digit)
	Flush head Push Button with 1 NC Block	TD1□AB2	1-Red 2-Green 3-Black 4-Yellow 5-White/Opal 6-Blue 7-Orange
	Flush head Push Button with 1 NO Block	TD1□AA2	1-Red 2-Green 3-Black 4-Yellow 5-White/Opal 6-Blue 7-Orange
	Projecting head Push Button with 1 NC Block	TD4□AB2	1-Red 2-Green 3-Black 4-Yellow 5-White/Opal 6-Blue 7-Orange
	Projecting head Push Button with 1 NO Block	TD4□AA2	1-Red 2-Green 3-Black 4-Yellow 5-White/Opal 6-Blue 7-Orange

TEEKAY Series

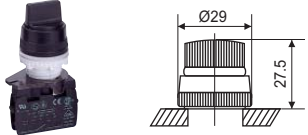
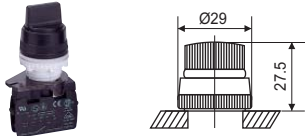
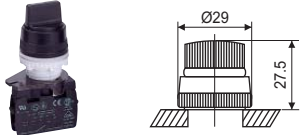
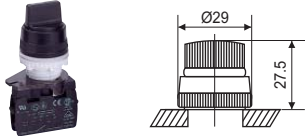
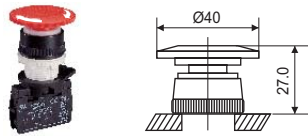
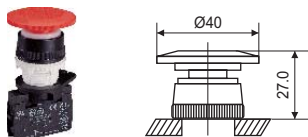





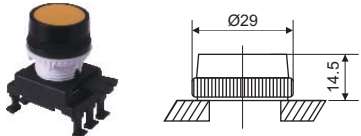
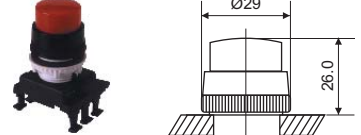



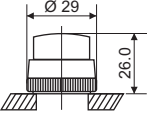

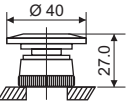

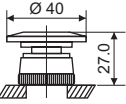

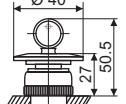

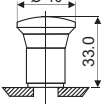

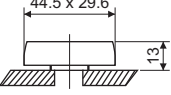
	Description	Cat. No.	Colour (4 th Digit)
	Symmetrical head 2 position selector switch (NSR) with 1 NC Block	TK63AB2	3-Black
	Symmetrical head 2 position selector switch (NSR) with 1 NO Block	TK63AA2	3-Black
	Symmetrical head 2 position selector switch (SR) with 1 NC Block	TI63AB2	3-Black
	Symmetrical head 2 position selector switch (SR) with 1 NO Block	TI63AA2	3-Black
	Mushroom Head Push Turn Actuator with 1 NC	TH5□AB2	1-Red 2-Green 3-Black 4-Yellow
	Mushroom Head Push Turn Actuator with 1 NO	TH5□AA2	
	Mushroom Head Push Function Actuator with 1 NC	TD5□AB2	1-Red 2-Green 3-Black 4-Yellow
	Mushroom Head Push Function Actuator with 1 NO	TD5□AA2	

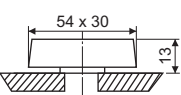
Standard Push Button & Selector Actuators Ø 22.5 mm

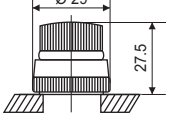
- Contact blocks HC61A2 & HC61B2



	Description	Cat. No.	Colour (6 th Digit)
	Flush Head	HD15C□	1-Red 2-Green 3-Black 4-Yellow 5-White/Opal 6-Blue 7-Orange 8-Colorless
	Projecting Head 'Push Function'	HD45C□	1-Red 2-Green 3-Black 4-Yellow 5-White/Opal 6-Blue 7-Orange 8-Colorless

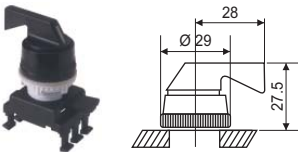
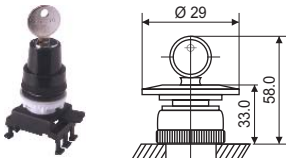
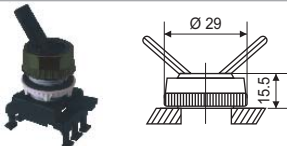
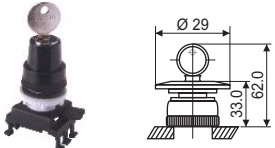

Standard Push Button & Selector Actuators Ø 22.5 mm

		Description	Cat. No.	Colour (6 th Digit)
		Projecting Head 'Push - Push Function'	HF45C □	1-Red 2-Green 3-Black 4-Yellow 5-White/Opal 6-Blue 7-Orange
		Mushroom Head Ø 40 mm 'Push Function'	HD55C □	1-Red 2-Green 3-Black 4-Yellow
		Mushroom Head 'Push Turn'	HH55C □	1-Red 2-Green 3-Black 4-Yellow
		Mushroom Head With Lock & Key	HQ55C □	1-Red 2-Green 3-Black 4-Yellow
		Mushroom Head 'Push Pull'	HG55B □	1-Red 2-Green 3-Black 4-Yellow 6-Blue
		Twin Touch	HD15G0	
		Twin Touch	HD15G □	3-Black 4-Yellow 5-White/Opal 6-Blue 7-Orange 8-Colourless
		Symmetric Head	<p>2 Position</p> <p>Non Spring Return  HK65C□</p> <p>Spring Return  HI65C□</p> <p>3 Position</p> <p>Non Spring Return  HL65C□</p> <p>Spring Return  HJ65C□</p> <p>Spring Return from L. H.  HM65C□</p> <p>Spring Return from R. H.  HN65C□</p>	1-Red 2-Green 3-Black 5-White/Opal

Standard Push Button & Selector Actuators Ø 22.5 mm

	Description	Cat. No.	Colour (4 th Digit)	
	Lever Head	2 Position	1-Red 3-Black 5-White/Opal	
		Non Spring Return		HK75C□
		Spring Return		HI75C□
		3 Position		
		Non Spring Return		HL75C□
		Spring Return		HJ75C□
		Spring Return from L. H.		HM75C□
Spring Return from R. H.	HN75C□			
	Lock & Key Rotary Type	2 Position	3-Black	
		Non Spring Return		HK85C□
		Spring Return		HI85C□
		3 Position		
		Non Spring Return		HL85C□
		Spring Return		HJ85C□
		Spring Return from L. H.		HM85C□
Spring Return from R. H.	HN85C□			
	Tip Head	2 Position	1-Red 2-Green 3-Black 4-Yellow 5-White/Opal	
		Non Spring Return		HP95C□
	Lock & Key Push Turn	2 Position	3-Black	
		Non Spring Return		HH85C□

Note * In 2 position selector actuator, for operating style  replace 2nd digit from K to R and for operating style  replace 2nd digit from K to T
 ** For Lock & Key, Key removable position Left, Right or Both





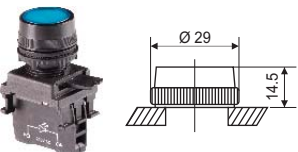

- Note :**
- Actuators & Selector Actuators with black ABS collar are offered as Standard eg. : HD15 
 - Actuators (except Mushroom Head Push - Pull & all types of twin touch Actuators) are also available with chrome plated ABS & Brass collar
 - For Chrome plated ABS Collar replace 5 th digit C by A eg. : HD15 
 - For Brass Chrome plated ABS Collar replace C by B eg. : HD15 
 - For Non-Illuminated Actuator / Selector Actuator at least 1 NO or NC Block required to make a complete Assembly
 eg. HD15C1 + HC61A2 makes complete assembly of flush head actuator with 1 NO Block

Standard Illuminated Actuators With LED

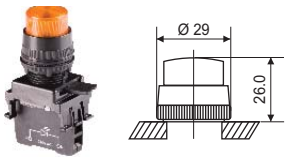
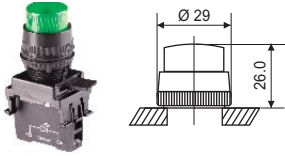
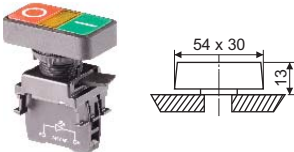
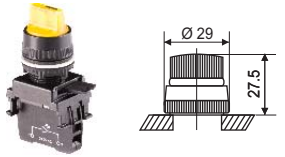
- Illuminated Actuators Pre-assembled with LED Holder
- Contact blocks HC61A2 & HC61B2



	Description	Cat. No.	Colour (4 th Digit)	Voltage (5 th , 6 th , 7 th & 8 th Digit)
	Flush Head	EAL□□□□FD1	R-Red	012C - 12 V AC/DC
			G-Green	024C - 24 V AC/DC
			Y-Yellow	048C - 48 V AC/DC
			A-Amber	064C - 64 V AC/DC
				110A - 110 V AC
			B-Blue	110D - 110 V DC
			W-White	240A - 240 V AC
				220D - 220 V DC

Standard Illuminated Actuators With LED

	Description	Cat. No.	Colour (4 th Digit)	Voltage (5 th , 6 th , 7 th & 8 th Digit)	
	Projecting Head (Push Function)	EAL□□□□PD1	R-Red G-Green Y-Yellow A-Amber	012C - 12 V AC/DC 024C - 24 V AC/DC 048C - 48 V AC/DC 064C - 64 V AC/DC 110A - 110 V AC 110D - 110 V DC 240A - 240 V AC 220D - 220 V DC	
			B-Blue W-White		
	Projecting Head (Push - Push Function)	EAL□□□□PF1	R-Red G-Green Y-Yellow A-Amber	012C - 12 V AC/DC 024C - 24 V AC/DC 048C - 48 V AC/DC 064C - 64 V AC/DC 110A - 110 V AC 110D - 110 V DC 240A - 240 V AC 220D - 220 V DC	
			B-Blue W-White		
	Twin Touch	EAL□□□□TD1	Y-Yellow A-Amber	012C - 12 V AC/DC 024C - 24 V AC/DC 048C - 48 V AC/DC 064C - 64 V AC/DC 110A - 110 V AC 110D - 110 V DC 240A - 240 V AC 220D - 220 V DC	
	Selector Actuator with Gen Next LED	2 Position Non Spring Return 	EAL□□□□SK1	R-Red G-Green Y-Yellow A-Amber	012C - 12 V AC/DC 024C - 24 V AC/DC 048 C - 48 V AC/DC 064 C - 64 V AC/DC 110A - 110 V AC 110D - 110 V DC 240A - 240 V AC 220D - 220 V DC
		2 Position Spring Return 	EAL□□□□SI1	B-Blue W-White	
		3 Position Non Spring Return 	EAL□□□□SL1	R-Red G-Green Y-Yellow A-Amber	
		3 Position Spring Return 	EAL□□□□SJ1	R-Red G-Green Y-Yellow A-Amber	
		3 Position Spring Return from L. H. 	EAL□□□□SM1	B-Blue W-White	
		3 Position Spring Return from R. H. 	EAL□□□□SN1		

Note* : 1) In 2 position selector actuator, for operating style  replace 10th digit from K to R and for operating style  replace 10th digit from K to T.
2) Assembly comes with LED holder. Please order contact block **HC61A2** and **HC61B2** separately.
3) For Illuminated Actuators / Selector Actuators at least 1 LED Holder is required for electrical connection.

Standard Modular Contact Blocks

	Description	Cat. No.	Colour (4 th Digit)	Voltage (5 th , 6 th , 7 th & 8 th Digit)
	'NO' Block	HC61A2	-	-
	'NC' Block	HC61B2	-	-
	LED Holder for Standard series	EHL□□□□□	R-Red G-Green Y-Yellow A-Amber B-Blue W-White	012C - 12 V AC/DC 024C - 24 V AC/DC 048C - 48 V AC/DC 064C - 64 V AC/DC 110A - 110 V AC 110D - 110 V DC 240A - 240 V AC 220D - 220 V DC

Standard Push Button Stations (in ABS Engineering plastic body)

- Dimension
- Single Station : 74 x 70 x 48.5 mm
 - Two Station : 107 x 70 x 48.5 mm
 - Three Station : 140 x 70 x 48.5 mm

	Description	Cat. No.
	Mushroom Head Actuator 'Push Function' with Legend - STOP Contact - 1 'NC' for Stop	JAE10000
	Mushroom Head Actuator 'Push Turn Type' with Legend - STOP Contact - 1 'NC' for Stop	JAF10000
	Mushroom Head Actuator with Lock and Key on Yellow Cover, with legend - STOP, Contact - 1 'NC' for Emergency Stop	JAG10000
	Push Button Station with Push Pull Emergency Switch, Red with 1 NC	TJ51B2
	Flush Head Actuator - Red with Legend - STOP Contact - 1 'NC'	JAA10000
	Flush Head Actuator - Green with Legend - START Contact - 1 'NO'	JAB20000
	Illuminated Actuator - Red with Legend - OFF Contact - 1 'NC' Bulb Holder with Bulb 240 V AC	JAC50000
	Illuminated Actuator - Green with Legend - ON Contact - 1 'NO' Bulb Holder with Bulb 240 V AC	JAD60000
	Two Position Symmetric Head Selector Switch - Black with Legend - OFF / ON Contact - 1 'NO'	JAH20000
	Two Position Lock & Key Rotary Switch with Legend - OFF / ON Contact - 1 'NO'	JAI20000
	Flush Head Actuator - Green with Legend - START Contact - 1 'NO' (Station One)	JBB2A100
	Flush Head Actuator - Red with Legend - STOP Contact - 1 'NC' (Station Two)	
	Flush Head Actuator - Green with Legend - START Contact - 1 'NO' (Station One)	JBB2F100
	Mushroom Head Actuator 'Push Turn Type' with Legend - STOP Contact - 1 'NC'	
	Pilot Light 240 V AC Colourless Lens (Station One)	JCZ4B2A1
	Flush Head Actuator - Green with Legend - START Contact - 1 'NO' (Station Two)	
	Flush Head Actuator - Red with Legend - STOP Contact - 1 'NC' (Station Three)	
	Flush Head Actuator - Green with Legend - FORWARD Contact - 1 'NO' (Station One)	JDB2A1B2
	Flush Head Actuator - Red with Legend - STOP Contact - 1 'NC' (Station Two)	
	Flush Head Actuator - Green with Legend - REVERSE Contact - 1 'NO' (Station Three)	
	Flush Head Actuator - Green with Legend - UP Contact - 1 'NO' (Station One)	JEB2A1B2
	Flush Head Actuator - Red with Legend - STOP Contact - 1 'NC' (Station Two)	
	Flush Head Actuator - Green with Legend - DOWN Contact - 1 'NO' (Station Three)	





Note : All standard push button stations contains base mounted contact blocks.

Standard Push Button Stations (in ABS Engineering plastic body)

Push Buttons Station Enclosure with contact block

	Description	Cat. No.	
	All Grey single hole	HF999004	
	All Grey & 2 hole of Ø 22.5	HF999005	
	All Grey & 3 holes of Ø 22.5	HF999003	
	Single hole yellow cover & gray base	HF995001	
	Base mounted contact block for Push Button Stations	'NO' Contact Block	HC42A2
		'NC' Contact Block	HC42B2
		1 'NO' + 1 'NC' Contact Block	HC42C2
		2 'NO' Contact Block	HC42D2
		2 'NC' Contact Block	HC42E2
		Bulb Holder with Bulb 240 V AC+ 'NO' Contact Block	HC22N1
	Bulb Holder with Bulb 240 V AC+ 'NC' Contact Block	HC22O1	

Standard All Purpose Enclosures



	Description	Cat. No.
 <p>Dimension: 110 X 80 X 65 mm</p>	All Grey without hole	HF999000
 <p>Dimension: 170 X 85 X 80 mm</p>	All Grey & 1 hole of Ø 22.5	HF999001
 <p>Dimension: 80 X 82 X 85 mm</p>	All Grey & 2 holes of Ø 22.5	HF999002
 <p>Dimension: 170 X 85 X 80 mm</p>	4 Station Enclosure (maximum 3 NO/NC per button)	HF999024
 <p>Dimension: 80 X 82 X 85 mm</p>	1 Station Enclosure (maximum 4 NO or NC)	HF999026

Note: Only standard series actuators and contact block (HC61A2 & HC62B2) can be used to convert all purpose enclosure box into standard push button station.

Accessories and Spares for Standard series

Clips for Modular Blocks	Description	Cat. No.
	Second Row Clip (For Vertical Cascading)	HC122030
	Side Row Clip (For Horizontal Cascading)	HC929002
	First Row Clip	HC922002
	Single Leg Clip	HE102000

Note : First Row Clip is included for all std series Push Button Actuators, Selector Actuators & Mushroom Head Assembly

Modular Blocks (Bulb Holders with Series Resistor)	Bulb Rating	Cat. No.	Supply Voltage
	6 V, 2 W	HC61S1	6 V AC/DC
	12 V, 2 W	HC61T1	12 V AC/DC
	24 V, 2 W	HC61U1	24 V AC/DC
	48 V, 2 W	HC61V1	48 V AC/DC
	130 V, 20 mA	HC61W1	110 V AC/DC
Bulb Holder with Built in Resistor & Diode	130 V, 20 mA Bulb	HC61X1	240 V AC Supply
Bulb Holder without Resistor & Diode		HC61R1	6 V/12 V/24 V/48 V 110 V AC/DC
Filament Lamps (BA 9S Type) 		HC550001	6 V AC/DC
		HC550002	12 V AC/DC
		HC550003	24 V AC/DC
		HC550004	48 V AC/DC
		HC550005	130 V AC/DC

Fixing Device	Cat. No.
	HH192000



Lamp Extractor	Cat. No.
	HH157000



Shroud (Boot) for Actuator	Cat. No.	Colour
	HH152002	Red
	HH153003	Green
	HH154004	Black
	HH155005	Yellow
	HH150100	Colourless

Spare Lens Cap	Colour	Cat. No.	
		Non Illuminated	Illuminated
	Red	HB103002	HB103103
	Green	HB104000	HB104101
	Black	HB102006	NA
	Yellow	HB105008	HB105109
	White/Opal	HB101004	HB101105
	Blue	HB107010	HB107111
	Orange	HB108012	HB108113
	Colourless	NA	HB100107

Note: It can be used for Gen Next as well as standard series indicator & actuators.

		Cat. No.	Colour
Collar (For Flush/ Projecting Head)		HB192000	Chrome Plated 'ABS'
		HB196000	Black
		HB326000	Brass
Adaptor Ring (For 30 to 22 mm in Panel Cutout conversion)		HH180000	Gray
		HH182004	Chrome Plated 'ABS'
		HH196006	Black
Blanking Plugs		HH180002	Gray
		HH182009	Black
		HH196010	Chrome Plated 'ABS'
Center Indication Strip (For Twin Touch Actuator)		HB102058	Black
		HB105163	Yellow
		HB108169	Orange
		HB100161	Colourless

Metal Plates - Spare	Cat. No.
 Small	HH2420122
 Large	HH2420124
 Square	HH2420123

Plastic Plate	Cat. No.
 Yellow legend plate	HB135000
 Protecting Shroud	HF195004

Note: Printing as per customer requirement

Product	16mm Gen Next LED Indicators	22.5 mm Gen next LED Indicators	Gen next LED Actuators
Rated Voltage	12 V AC/DC	12 V AC/DC	12 V AC/DC
	24 V AC/DC	24 V AC/DC	24 V AC/DC
	30 V AC/DC	30 V AC/DC	30 V AC/DC
	48 V AC/DC	48 V AC/DC	48 V AC/DC
	63.5 V AC/DC	63.5 V AC/DC	63.5 V AC/DC
	110 V AC/DC	110 V AC, 110 V DC	110 V AC, 110 V DC
	240 V AC	240 V AC, 240 V DC	240 V AC, 240 V DC
Operating Voltage	-20% to +10% of rated voltage		
Type of LED	SMD LEDs		
Available Colours	Red, Green, Yellow, Amber, Blue and White		
Power Consumption	< 0.6 W		
Insulation Resistance	> 100 Ω at 500 V DC		
Dielectric Strength	1.5 kV AC for 60 sec		
Life	1,00,000 burning hours		
Panel cutout required	EIL series - Ø 22.5 mm, Ø 30.5 mm with adapter ring, SIL series - Ø 16 mm		
Overall Dimension	EIL series - Ø 29 X 52 mm (approx), SIL series - Ø 19.9 X 49 mm (approx)		
Operating Temperature	-30°C to 60°C		
Degree of Protection	IP 65 : Above panel and IP 20 :for terminals		
International Approvals	CE	CE, UL	CE

Gen Next Integral Actuator

Product	Gen Next Integral Actuator
Function Type	Push, Push-Push, Push Turn, Selector
Contact	NO, NC, NO+NC, 2 NO, 2 NC
Type	Non-Illuminated
Colour	Red / green / black / yellow / orange / blue / white
Rated Operational Levels	6A, 230 V AC
Electrical Cycle	5 Lac operations
Mechanical Cycle	10 Lac operations
Operating Temperature	-30°C to 60°C
Operating Force	Max 8 N
Degree of Protection	IP 65 : Above panel and IP 20 :for terminals
Rated Insulational Voltage	600 V AC
Terminals	Suitable for flexible or solid conductors from 2 x 1 mm ² to 2 x 2.5 mm ²
Contact Material	AgNi / AgCdo
Insulation Resistance at 500 V DC	> 50m Ω
Contact Resistance	< 20m Ω
MV drop at 16 ADC	< 200 mV
Disposition of contacts	<div style="display: flex; align-items: center;"> <div style="margin-right: 20px;"> <p><input type="checkbox"/> Contact Open</p> <p><input checked="" type="checkbox"/> Contact Close</p> </div> </div>

Gen Next Modular Contact Block

Product	Gen next modular contact block
Electrical cycle	5 Lac operations
Mechanical cycle	10 Lac operations
Operating Temperature	-30°C to 60°C
Operating Force	Max 3.5 N
HV test for 60 sec	2.5 kV
Rated Insulation Voltage	600 V AC
Terminals	Suitable for flexible or solid conductors from 2 x 1 mm ²
Contact Material	AgNi
Rated Thermal Current	16 A with 2.5 mm ² flexible conductors
Insulation Resistance at 500 V DC	> 50 m Ω
Contact Resistance	< 20 m Ω
MV drop at 16 ADC	< 100 mV

Actuator, Indicators, Modular & Front Connection Blocks

Electrical Ratings (IEC 60947-5-1, 2003)							
Alternating Current	Rated Operating Voltage (50-60 Hz)		V	110	230	440	500
	Rated Operating Current (IEC 60947-5-1)	AC 15	Amp	8	6	3	2
Direct Current	Rated Operating Voltage (50-60 Hz)		V	24	48	110	220
	Rated Operating Current (IEC 60947-5-1)	DC13	Amp	1.5	1.0	0.3	0.2

UL Electrical Ratings (UL 508)											
Contact Rating Code Designation,	Thermal Continuous Test Current,	Maximum Current								Maximum VA	
		120 V		240 V		480 V		600 V			
AC	Amp	Make	Break	Make	Break	Make	Break	Make	Break	Make	Break
A 600	10	60	6	30	3	15	1.5	12	1.2	7200	720

Contact Rating Code Designation, DC	Thermal Continuous Test Current, Amp	Maximum Make & Break Current, Amp		Maximum Make & Break at 300 V or less, VA
		125 V	250 V	
P 300	5	1.1	0.55	138

Electrical Life at 240 V, 50-60 Hz, AC, utilization category AC15 to IEC 60947-5-1		Rated Thermal Current		16 Amp with, 2.5 mm ² flexible conductor
Rated current Amps	Operations (x10 ⁶)	Mechanical Life		1 x 10 ⁶ operations
6	0.5	Rated Insulation Voltage		600 V
2	1	Dielectric / H. V. Test Voltage		2.5 kV AC for 60 sec
Actuators		Terminals		
Degree of Protection	IP65 IP67 with rubber / vinyl shroud	Suitable for flexible or solid conductors from 2 x 1 mm ²		
Operational Temperature Limits (without shroud)		Disposition of Contacts for Modular Blocks		
Non-illuminated	illuminated	<div style="display: flex; align-items: center;"> <div style="margin-right: 10px;"> <div style="width: 10px; height: 10px; border: 1px solid black; background-color: white; display: inline-block;"></div> Contact Open NC </div> <div style="margin-right: 10px;"> <div style="width: 10px; height: 10px; border: 1px solid black; background-color: black; display: inline-block;"></div> Contact Close NO </div> </div>		
-30 to + 60°C	-30 to + 40°C	0 1 2 3 4 4.8		
Rated Insulation Voltage		600 V AC		
Dielectric / H. V. Test Voltage at 2.5 kV AC for 60 sec				
Mechanical Life	Flush Head	5 Lac		
	Mushroom Head	1 Lac		
	Selector Actuator	1 Lac		

Note : IP 67 Rubber/ Vinyl Shroud is available for Standard series only.

Push Button Stations & General Purpose Enclosures

Degree of Protection:

Dust and watertight to IP67 with shroud, IP65 without shroud.

Safety:

Fully insulated to house electrical and electronic equipment with respect to protection against electrical shock.

Materials:

Base : Tough, impact resistant, ABS.

Cover : Tough, impact resistant, ABS.

Cover Screws :

- Standard Series: Slotted head, metal screws for Push Button stations and tough, low friction PA6 captive cross slot head screws for all purpose enclosures.
- Gen Next series: Half Threaded self tapping cold forged screws with blacodising

Gasket : Oil and acid resistant nitrile rubber.

Terminal Capacity:

1 to 2.5 mm square flexible wire

Mounting:

Directly through base, in cover screw cavity, outside gas kitted area with No.4 size, sheet metal screws.

Machining:

Machining is easy with normal tools. Enclosures can be drilled, sawed, filed, punched etc. They can be welded with ultrasonic equipment.

Maintenance:

Do not need any particular maintenance. If necessary, soap and water can be used for cleaning. If detergent is used, enclosure should be rinsed well with clean water. **Do not use any solvents to clean the enclosures.**

Chemical resistance:

ABS products are almost completely resistant to aqueous acids, alkalis and salts. Concentrated phosphoric and hydrochloric acids have little effect. Low KB solvents, alcohols and animal / vegetable / mineral oils produce insignificant changes. Aromatic or chlorinated hydrocarbons and high KB solvents cause marked swelling. Esters, Ketones and Unsaturated alkalis are solvents for ABS and should not be used.

Chemical resistance:

Long term exposure to temperatures above 70°C should be avoided. No significant change in impact strength is noticed upto - 20°C.

Gen Next Push Button Stations

Dimension

- Single Station : 65 x 55 x 33 mm
- Two Station : 100 x 55 x 53 mm
- Three Station : 134 x 55 x 53 mm
- Eight Station: 305 x 55 x 53 mm

Standard Push Button Stations (in ABS Engineering plastic body)

Dimension

- Single Station : 74 x 70 x 48.5 mm
- Two Station : 107 x 70 x 48.5 mm
- Three Station : 140 x 70 x 48.5 mm

Panel Mounted 22.5 dia Buzzer

Product	Panel Mounted Buzzer
Rated Voltage	24 V AC/DC
	30 V AC/DC
	48 V AC/VDC
	63.5 V AC/DC
	110 V AC
	110 V DC
	240 V AC
Limit of Operating Voltage	-20% to +10% of rated voltage
Buzzer Colour	Black
Sound output	80 dB at 1 meter
Operating Temperature	-30°C to 60°C
Surge Test	2 kV
HV Test for 60 sec.	2.5 kV
Degree of Protection	Above Panel : IP 55
	For terminals: IP 20
Contact material	Brass with tin plating
Power Consumption	< 0.6 W
Wire Termination capacity	Min 0.5 mm ² to 2.5 mm ²
Terminal Torque	0.5 Nm
Mode	Continuous

Integral Actuator

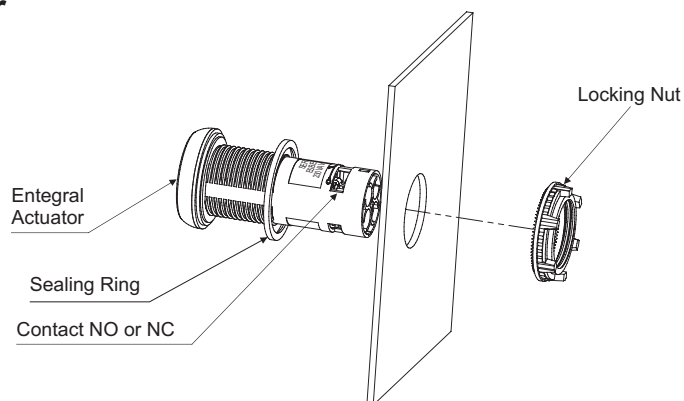

Gen Next Actuator

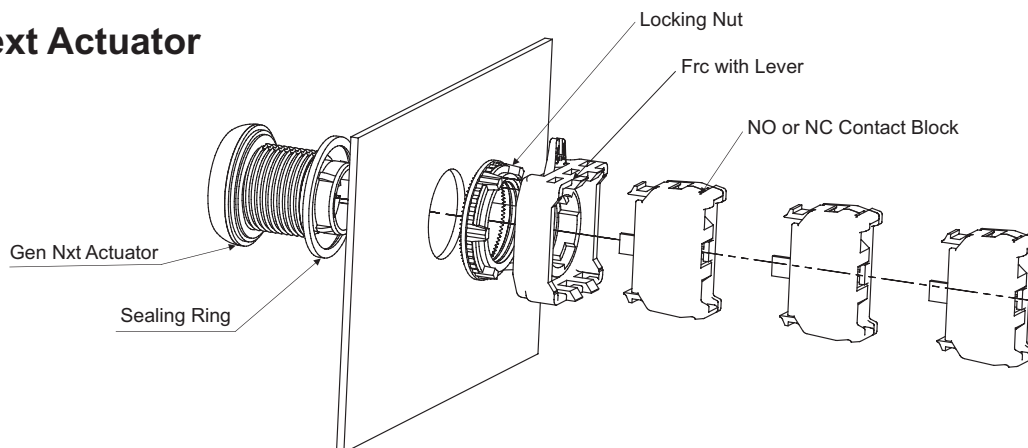

Standard Series

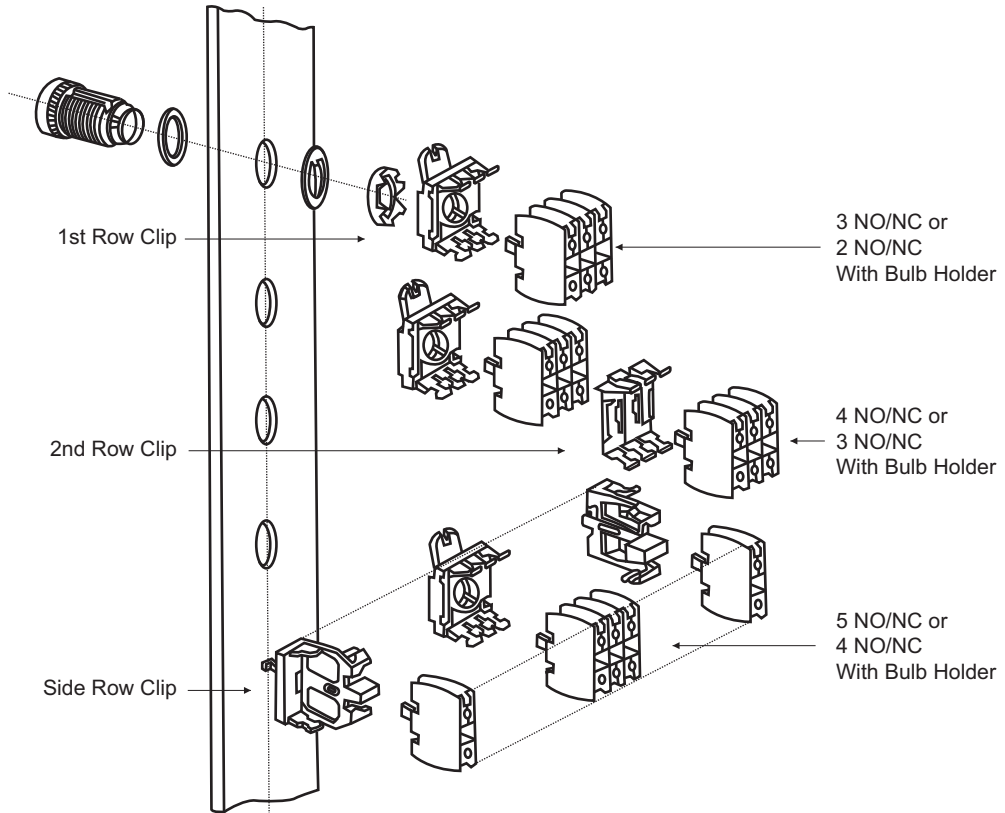

Gen Next series

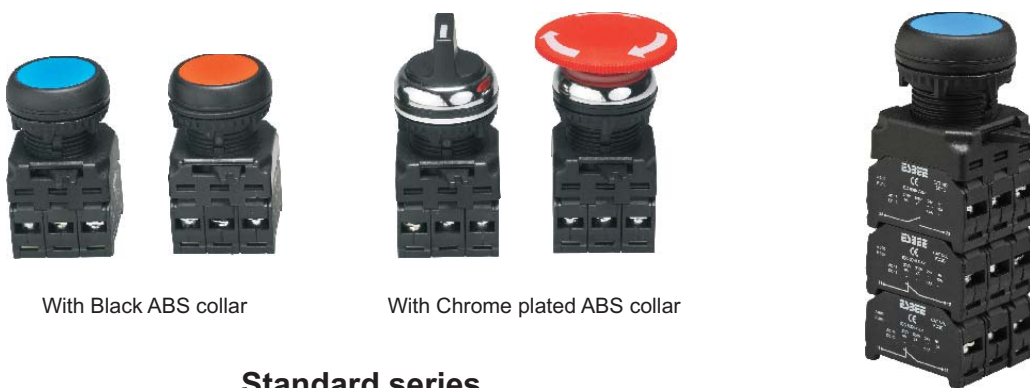

With Black ABS collar

With Chrome plated ABS collar

Gen Next actuator with
snap fit contacts.
Maximum 3 X 3 contacts

Standard series



With Black ABS collar

With Brass collar



Analog Panel Meters & CT

L&T's Ivory series of analog panel meters and current transformer provide you with reliable monitoring and indication of various electrical parameters.

The product range includes:

- Ammeters
- Voltmeters
- Wattmeters
- VAR meter
- Power factor meters
- Frequency meters
- Current transformers
 - Rectangular
 - Ring type

The analog meters have wide current measuring range of 100 mA to 100 A and voltage measuring range of 6 V to 1000 V. They provide flexibility and ease in interchangeability of scales thus reducing the inventory levels.

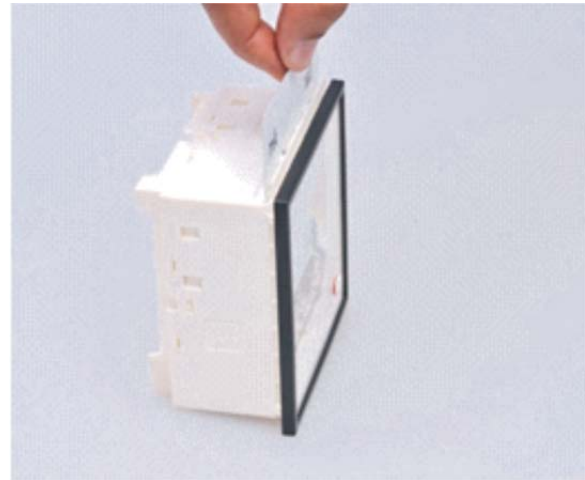

It is available in sizes of 72 x 72, 96 x 96 and 144 x 144 and scale – 90 degree.

The limited range of CTs includes the 7 most popular sizes with ratio ratings from 30/5 to 4000/5. It also has a wide range of current ratings, busbar sizes, case widths and apertures. They have sealable terminal covers with base mounting and busbar mounting option.

They are used in switchgear, distribution system, generator sets, control panels, overload protection.

Indicating Meters

- Interchangeable scales
- Back cover as standard
- Easy glass replacement
- Robust case with superior finish

Type of instrument	Moving iron for AC current & voltage measurement (DE)	Moving coil for DC current & voltage measurement (DS)	Moving coil with built in transducer for power measurement (LM)	Moving coil built in transducer for power factor measurement (LF)	Moving coil with built in transducer for frequency measurement (FM)
Size (mm)	72 x 72, 96 x 96, 144 x 144	72 x 72, 96 x 96	96 x 96, 144 x 144	72 x 72, 96 x 96, 144 x 144	72 x 72, 96 x 96, 144 x 144
Measurement	Alternating current & alternating voltage	Direct current & Direct voltage	Power for all type of network & loading	P.F. for all types & 3 Phase balanced & unbalanced network	Frequency for all type of network
Depth behind bezel	< 30 A = 53 mm, 30 A - 60 A = 62 mm, > 60 A = 67 mm	< 6 A = 53 mm, 6 A - 60 A = 67 mm, > 60 A = 78 mm	105 mm & 131 mm for 3 phase 4 wire unbalanced loads	53 mm 53 mm	
Smallest measuring range	6 V, 100 mA	15 mV, 15/uA	Related to rated voltage 57.7 V & rated current 1 A	Related to rated voltage 57.7 V & rated current 1 A	Related to rated voltage 57.7 V (min 45 Hz)
Largest measuring range	600 V, 100 A	600 V, 100 A	Related to rated voltage 500 V & rated current 5 A	Related to rated voltage 500 V & rated current 5 A	Related to rated voltage 500 V (max. 440 Hz)
Proof voltage	3 kV AC	3 kV AC	2 kV AC	2 kV AC	2 kV AC
Weight (approx. in kg)	72 x 72 = 0.20 96 x 96 = 0.25 144 x 144 = 0.30	72 x 72 = 0.20 96 x 96 = 0.25	96 x 96 = 0.65 - 1.10 144 x 144 = 0.85 - 1.30	72 x 72 = 0.29 96 x 96 = 0.32 144 x 144 = 0.52	72 x 72 = 0.25 96 x 96 = 0.30 144 x 144 = 0.60
Accuracy class	1.5	1.5	1.5	1.5	0.5

*For Ordering Information please refer price list of analog panel meters.

Moving Iron Type AC Meter (90 Degree)

AC Voltmeter

Cat. No.*	Description
XXX001	0 - 6 V
XXX002	0 - 10 V
XXX003	0 - 15 V
XXX004	0 - 25 V
XXX005	0 - 40 V
XXX007	0 - 60 V
XXX008	0 - 100 V
XXX009	0 - 150 V
XXX011	0 - 250 V
XXX012	0 - 300 V
XXX013	0 - 400 V
XXX014	0 - 500 V
XXX015	0 - 600 V
XXX018	Any other voltmeter upto 750 V
XXX020	0 - 5 kV PTR 3.3 kV / 110 V
XXX021	0 - 15 kV PTR 11.0 kV / 110 V
XXX022	0 - 40 kV PTR 33.0 kV / 110 V
XXX027#	Any other PT operated voltmeter upto 750 V

Specify PT ratio & scale

AC Ammeter

Cat. No.*	Description
XXX028	0 - 100 mA
XXX029	0 - 150 mA
XXX030	0 - 250 mA
XXX031	0 - 400 mA
XXX032	0 - 600 mA
XXX034**	0 - 1 A
XXX035**	0 - 1.5 A
XXX036**	0 - 2.5 A
XXX037**	0 - 4 A
XXX038**	0 - 5 A
XXX039**	0 - 6 A
XXX040**	0 - 10 A
XXX041**	0 - 15 A
XXX043**	0 - 25 A
XXX044**	0 - 30 A
XXX045**	0 - 40 A
XXX046**	0 - 50 A
XXX047**	0 - 60 A
XXX957**	0 - 80 A
XXX048**	0 - 100 A

AC Ammeter - CT Operated Type

Cat. No.*	Description
XXX052**	-1 A W/O Dial
XXX053 \$\$**	Specify Dial / 1 A
XXX094**	-5 A W/O Dial
XXX095 \$\$**	Specify Dial / 5 A

** Select Suppression from Table No. 1, \$\$ Select Dial from Table No. 2
 * XXX Select 111 for 72 x 72, 112 for 96 x 96, 113 for 144 x 144

Table 1. Select Suppression for Ammeter/Dials

**	Suppression
A1	X1 (No Suppression)
A6	X6 (For Dial)
A6	X6 (For Meter)
A2	X2 (Standard Suppression)

Accessories for AC Meter

Cat. No.	Description
199K300	Red Mark on Scale
199K400	Dual Scale
199P200	Accuracy 1%
199P500	Calibered 40 Hz to 400 Hz

Table 2. List of Dials for Ammeter

\$\$	Dial	\$\$	Dial	\$\$	Dial
AY	5 x 10 Div.	CF	50 A	CR	750 A
B1	2 x 10 Div.	CG	60 A	CS	800 A
B2	3 x 10 Div.	C6	75 A	CT	1000 A
B3	4 x 5 Div.	CH	100 A	CU	1200 A
B4	5 x 5 Div.	CI	120 A	CV	1250 A
B5	6 x 5 Div.	CJ	150 A	CW	1500 A
C7	5 A	CK	200 A	CX	1600 A
C9	10 A	CL	250 A	CY	2000 A
CA	15 A	CM	300 A	CZ	2500 A
CB	20 A	CN	400 A	D1	3000 A
CC	25 A	CO	500 A	D2	Any other Dial
CD	30 A	CP	600 A		
CE	40 A	CQ	700 A		

Power Factor Meter

Cat. No.*	Description
XXX131	E1C 0.5 - 1 - 0.5 ind 240 V, 1 A, 1 PH, 1 E, 2 W bal
XXX135	E1C 0.5 - 1 - 0.5 ind 240 V, 5 A, 1 PH, 1 E, 2 W bal
XXX331	E1C 0.8 - 1 - 0.8 ind 240 V, 1 A, 1 PH, 1 E, 2 W bal
XXX335	E1C 0.8 - 1 - 0.8 ind 240 V, 5 A, 1 PH, 1 E, 2 W bal
XXX411	D1C 0.5 - 1 - 0.5 ind 110 V, 1 A, 3 PH, 1 E, 3 W bal
XXX415	D1C 0.5 - 1 - 0.5 ind 110 V, 5 A, 3 PH, 1 E, 3 W bal
XXX461	D1C 0.5 - 1 - 0.5 ind 440 V, 1 A, 3 PH, 1 E, 3 W bal
XXX465	D1C 0.5 - 1 - 0.5 ind 440 V, 5 A, 3 PH, 1 E, 3 W bal
XXX611	D1C 0.8 - 1 - 0.8 ind 110 V, 1 A, 3 PH, 1 E, 3 W bal
XXX615	D1C 0.8 - 1 - 0.8 ind 110 V, 5 A, 3 PH, 1 E, 3 W bal
XXX661	D1C 0.8 - 1 - 0.8 ind 440 V, 1 A, 3 PH, 1 E, 3 W bal
XXX665	D1C 0.8 - 1 - 0.8 ind 440 V, 5 A, 3 PH, 1 E, 3 W bal
XXX801	D2C 0.5 - 1 - 0.5 ind 110 V, 1 A, 3 PH, 2 E, 3 W unbal
XXX802	D2C 0.5 - 1 - 0.5 ind 110 V, 5 A, 3 PH, 2 E, 3 W unbal
XXX803	D2C 0.5 - 1 - 0.5 ind 440 V, 1 A, 3 PH, 2 E, 3 W unbal
XXX804	D2C 0.5 - 1 - 0.5 ind 440 V, 5 A, 3 PH, 2 E, 3 W unbal
XXX805	V3C 0.5 - 1 - 0.5 ind 110 V, 1 A, 3 PH, 3 E, 4 W unbal
XXX806	V3C 0.5 - 1 - 0.5 ind 110 V, 5 A, 3 PH, 3 E, 4 W unbal
XXX807	V3C 0.5 - 1 - 0.5 ind 440 V, 1 A, 3 PH, 3 E, 4 W unbal
XXX808	V3C 0.5 - 1 - 0.5 ind 440 V, 5 A, 3 PH, 3 E, 4 W unbal

* XXX Select 174 for 72 x 72, 176 for 96 x 96, 177 for 144 x 144
 1E : 1 Element (CT), 2 W : 2 wire, 3 W : 3 wire

Power Meter

kW Meter

Cat. No.*	Description
XXX041	E1 W 240 V 1 A, 1 P, 1 E, 2 W bal
XXX045	E1 W 240 V 5 A, 1 P, 1 E, 2 W bal
XXX211	D2 W 110 V 1 A, 3 P, 2 E, 3 W unbal
XXX215	D2 W 110 V 5 A, 3 P, 2 E, 3 W unbal
XXX271	D2 W 440 V 1 A, 3 P, 2 E, 3 W unbal
XXX275	D2 W 440 V 5 A, 3 P, 2 E, 3 W unbal
XXX311	V1 W 110 V 1 A, 3 P, 1 E, 4 W bal
XXX315	V1 W 110 V 5 A, 3 P, 1 E, 4 W bal
XXX371	V1 W 440 V 1 A, 3 P, 1 E, 4 W bal
XXX375	V1 W 440 V 5 A, 3 P, 1 E, 4 W bal
XXX411	V3 W 110 V 1 A, 3 P, 3 E, 4 W unbal
XXX415	V3 W 110 V 5 A, 3 P, 3 E, 4 W unbal
XXX471	V3 W 440 V 1 A, 3 P, 3 E, 4 W unbal
XXX475	V3 W 440 V 5 A, 3 P, 3 E, 4 W unbal
XXX601	V3 W 440 V 5 A, 3 P, 3 E, 4 W unbal without dial
XXX602	V3 W 415 V 5 A, 3 P, 3 E, 4 W unbal without dial

* XXX Select 127 for 96 x 96, 128 for 144 x 144
 1E : 1 Element (CT), 2 W : 2 wire, 3 W : 3 wire

Transducer Type Meter

Frequency Meter

Cat. No.*	Description
XXX102	45 - 50 - 55 Hz 110 V
XXX311	45 - 50 - 55 Hz 240 V
XXX310	45 - 50 - 55 Hz 440 V

* XXX Select 122 for 72 x 72, 123 for 96 x 96, 124 for 144 x 144

kVAr Meter

Cat. No.*	Description
XXX541	E1B 240 V 1 A, 1 P, 1 E, 2 W bal
XXX545	E1B 240 V 5 A, 1 P, 1 E, 2 W bal
XXX711	D2B 110 V 1 A, 3 P, 2 E, 3 W unbal
XXX715	D2B 110 V 5 A, 3 P, 2 E, 3 W unbal
XXX771	D2B 440 V 1 A, 3 P, 2 E, 3 W unbal
XXX775	D2B 440 V 5 A, 3 P, 2 E, 3 W unbal
XXX911	V3B 110 V 1 A, 3 P, 3 E, 4 W unbal
XXX915	V3B 110 V 5 A, 3 P, 3 E, 4 W unbal
XXX971	V3B 440 V 1 A, 3 P, 3 E, 4 W unbal
XXX975	V3B 440 V 5 A, 3 P, 3 E, 4 W unbal

* XXX Select 127 for 96 x 96, 128 for 144 x 144

DC Ammeter

Cat. No.*	Description
XXX022	0 - 1 mA
XXX023	0 - 1.5 mA
XXX025	0 - 2.5 mA
XXX026	0 - 4 mA
XXX027	0 - 5 mA
XXX028	0 - 6 mA
XXX029	0 - 10 mA
XXX030	0 - 15 mA
XXX031	0 - 20 mA
XXX032	0 - 25 mA
XXX033	0 - 40 mA
XXX034	0 - 60 mA
XXX035	0 - 100 mA
XXX036	0 - 150 mA
XXX037	0 - 250 mA
XXX038	0 - 400 mA
XXX039	0 - 600 mA
XXX040	0 - 1 A
XXX041	0 - 1.5 A
XXX043	0 - 4 A
XXX044	0 - 5 A
XXX045	0 - 6 A
XXX046	0 - 10 A
XXX047	0 - 15 A
XXX048	0 - 20 A
XXX049	0 - 25 A
XXX050	0 - 30 A
XXX051	0 - 40 A
XXX052	0 - 60 A
XXX053	0 - 100 A
XXX054	Any other Direct DC Ammeter upto 100 A

Moving Coil Type DC Meter

DC Ammeter - Shunt Operated Type

Cat. No.*	Description
XXX091	---/50 mV W/O Dial
XXX092\$\$	Specify Dial / 50 mV
XXX093	---/60 mV without DI
XXX094\$\$	Specify Dial / 60 mV
XXX131	---/75 mV without DI
XXX132\$\$	Specify Dial / 75 mV
XXX256	---/60 mV..0..60 mV without Dial centre Zero
XXX257\$\$	Specify Dial / 60 - 0 - 60 mV centre Zero
XXX294	---/75 mV..0..75 mV Without Dial centre Zero
XXX295\$\$	Specify Dial / 75 - 0 - 75 mV centre Zero

\$\$ Select suitable Dial from Table 2

* XXX Select 115 for 72 x 72, 116 for 96 x 96

DC Voltmeter

Cat. No.*	Description
XXX068	0 - 1 V
XXX069	0 - 1.5 V
XXX070	0 - 2.5 V
XXX071	0 - 4 V
XXX072	0 - 6 V
XXX073	0 - 10 V
XXX074	0 - 15 V
XXX075	0 - 25 V
XXX076	0 - 30 V
XXX077	0 - 40 V
XXX079	0 - 60 V
XXX081	0 - 100 V
XXX082	0 - 150 V
XXX083	0 - 200 V
XXX084	0 - 250 V
XXX085	0 - 300 V
XXX086	0 - 400 V
XXX087	0 - 500 V
XXX088	0 - 600 V
XXX090	Any other direct voltmeter upto 600 V

Special DC Meter

Cat. No.*	Description
XXX013	0 - 1 mA without Dial
XXX014	Specify Dial / 1 mA
XXX218	---/1 mA..0..1 mA WIT
XXX219	Specify Dial / 1 - 0 - 1 mA. Without Dial center zero
XXX340	0 - 10 V W/O Dial
XXX341	Specify Dial / 10 V
XXX056	4 - 20 mA W/O Dial
XXX055	Specify Dial / 4 - 20 mA

* XXX Select 115 for 72 x 72, 116 for 96 x 96

Current Transformer



Rectangular Type

Description	Cat. No.
CT Rect. 45 / 14, 50 / 5, 3.75 VA / Cl. 0.5	1P1801951
CT Rect. 45 / 14,60 / 5, 5 VA / Cl. 0.5	1P1801952
CT Rect. 45 / 21, 75 / 5, 5 VA / Cl. 0.5	1P1801953
CT Rect. 62 / 20, 100 / 5, 5 VA / Cl. 1	1P1800150
CT Rect. 62 / 30, 150 / 5, 7.5 VA / Cl. 1	1P1800094
CT Rect. 62 / 30, 200 / 5, 10 VA / Cl. 1	1P1801954
CT Rect. 62 / 30, 250 / 5, 10 VA / Cl. 1	1P1801955
CT Rect. 74 / 20, 300 / 5, 10 VA / Cl. 1	1P1800457
CT Rect. 74 / 20, 300 / 5, 15 VA / Cl. 1	1P1801956
CT Rect. 74 / 30, 400 / 5, 15 VA / Cl.1	1P1801957
CT Rect. 74 / 30, 500 / 5, 15 VA / Cl.1	1P1801958
CT Rect. 74 / 30, 600 / 5, 15 VA / Cl.1	1P1801959
CT Rect. 74 / 30, 800 / 5, 15VA / Cl. 1	1P1801960
CT Rect. 86 / 40, 000 / 5, 15 VA / Cl. 1	1P1801961
CT Rect. 86 / 50, 1200 / 5, 15 VA / Cl. 1	1P1801962
CT Rect. 86 / 60, 1500 / 5, 15 VA / Cl. 1	1P1801963
CT Rect. 104 / 60, 1600 / 5, 15 VA / Cl. 1	1P1801964
CT Rect. 140 / 80, 2000 / 5, 15 VA / Cl. 1	1P1801965
CT Rect. 140 / 100, 2500 / 5, 15 VA / Cl. 1	1P1801966
CT Rect. 140 / 100, 3000 / 5, 15 VA / Cl. 1	1P1801967
CT Rect. 140 / 100, 4000 / 5, 15 VA / Cl. 1	1P1801968



Round Type

Description	Cat. Nos.
CT Round TW - 2, 50 / 5, 5 VA / Cl. 0.5	1P1790266
CT Round TW - 2, 60 / 5, 5 VA / Cl. 0.5	1P1790267
CT Round TW - 2, 75 / 5, 5 VA / Cl. 0.5	1P1790268
CT Round TW - 2, 100 / 5, 5 VA / Cl. 1	1P1790025
CT Round TW - 2, 150 / 5, 5 VA / Cl. 1	1P1790269
CT Round TW - 2, 200 / 5, 10 VA / Cl. 1	1P1790037
CT Round TW - 2, 200 / 5, 15 VA / Cl. 1	1P1790038
CT Round TW - 3, 250 / 5, 10 VA / Cl. 1	1P1790049
CT Round TW - 3, 250 / 5, 15 VA / Cl. 1	1P1790050
CT Round TW - 3, 300 / 5, 10 VA / Cl. 1	1P1790056
CT Round TW - 3, 300 / 5, 15 VA / Cl. 1	1P1790057
CT Round TW - 4, 400 / 5, 15 VA / Cl. 1	1P1790066
CT Round TW - 4, 500 / 5, 15 VA / Cl. 1	1P1790076
CT Round TW - 4, 600 / 5, 15 VA / Cl. 1	1P1790089
CT Round TW - 5, 800 / 5, 15 VA / Cl. 1	1P1790105
CT Round TW - 5, 1000 / 5, 15 VA / Cl. 1	1P1790124
CT Round TW - 6, 1200 / 5, 15 VA / Cl. 1	1P1790142
CT Round TW - 6, 1500 / 5, 15 VA / Cl. 1	1P1790270
CT Round TW - 6, 1600 / 5, 15 VA / Cl. 1	1P1790271
CT Round TW - 6, 2000 / 5, 15 VA / Cl. 1	1P1790199
CT Round TW - 6, 2500 / 5, 15 VA / Cl. 1	1P1790216
CT Round TW - 6, 3000 / 5, 15 VA / Cl. 1	1P1790233
CT Round TW - 6, 3200 / 5, 15 VA / Cl. 1	1P1790250

Current Transformer

General Information

Standards	IEC60044-1, BS3938
Insulation	20% glass fiber reinforced polycarbonate case Flame retardant grades classified UL94 V-0
Rated voltage	720 V
Test voltage?	4 kV eff 50 Hz 1 min
Operating frequency	50 - 60 Hz
Rated secondary current	5 A or 1 A
Rated burden	1, 1.5, 2.5, 3.75, 5, 7.5, 10, 12.5, 15, 20, 30, 45, 60 VA
Class of accuracy	0.2, 0.2 s for laboratory and kWh measuring 0.5, 0.5 s for accurate measuring, kWh? 1 for general measuring with switchboard instruments 3 for other not so accurate measuring
Connection?	The secondary terminals have two connections on each side with M4 self clamp low contact resistance
Test certificate	Provided along with individual CT
Continuous over-current	1.2 x I _n

Current Transformer - Rectangular Type (Polycarbonate Case Encapsulated)

Frequency Rating 50 Hz or 60 Hz, Secondary Current 5 A

Primary current	Type	Dimensions (approx) in mm				Power Rating 9 (VA)	Accuracy Class
		A	B	C	D		
50	45 / D	45	65	40	14 Dia	3.75	5
60	45 / D	45	65	40	14 Dia	5	5
75	45 / D	45	65	40	21 Dia	5	5
100	62 / 20	62	78	40	20 x 12.5	5	1
150	62 / R	62	78	40	22 Dia	7.5	1
200	62 / 30	62	78	40	31 x 11	10	1
250	62 / 30	62	78	40	31 x 11	10	1
300	74 / 20	74	98	45	21 x 11	10	1
300	74 / 20	74	98	45	21 x 11	15	1
400	74 / 30	74	98	45	31 x 15	15	1
500	74 / 30	74	98	45	31 x 15	15	1
600	74 / 40	74	98	45	41 x 12.5	15	1
800	74 / 30	74	98	45	31 x 15	15	1
1000	86 / 40	86	110	45	41 x 11	15	1
1200	86 / 50	86	110	45	51 x 12.5	15	1
1500	86 / 60	86	110	45	61 x 12.5	15	1
1600	104 / 60	104	126	45	61 x 12.5	15	1
2000	140 / 80	140	155	45	81 x 31	15	1
2500	140 / 100	140	155	45	101 x 31	15	1
3000	140 / 100	140	155	45	101 x 31	15	1
4000	140 / 100	140	155	45	101 x 31	15	1

Current Transformer

Ring Type (Polycarbonate Case Encapsulated)

Primary current	Type	Dimensions (approx.) in mm			Power Rating 9 (VA)	Accuracy Class
		ID	OD	W		
50	TW - 2	30	73	50	5	5
60	TW - 2	30	73	50	5	5
75	TW - 2	30	73	50	5	5
100	TW - 2	30	73	50	5	1
150	TW - 2	30	73	40	5	1
200	TW - 2	30	73	50	10	1
200	TW - 2	30?	73	50	15	1
250	TW - 3	43	92	41	10	1
250	TW - 3	43	92	41	15	1
300	TW - 3	43	92	41	10	1
300	TW - 3	43	92	41	15	1
400	TW - 4	58	100	41	15	1
500	TW - 4	58	100	41	15	1
600	TW - 4	58	100	41	15	1
800	TW - 5	72	100	41?	15	1
1000	TW - 5	72	100	41	15	1
1200	TW - 6	113	159	40	15	1
1500	TW-6	113?	159	40	15	1
1600	TW - 6	113	159	40	15	1
2000	TW - 6	113	159	40	15	1
2500	TW - 6	113	159	40	15	1
3000	TW - 6	113?	159	40	15	1
3200	TW - 6	113	159	40	15	1

* The accuracies listed above are as per IS-2705/IEC-60044 * The general tolerance for dimensions shall be +/-0.2 mm

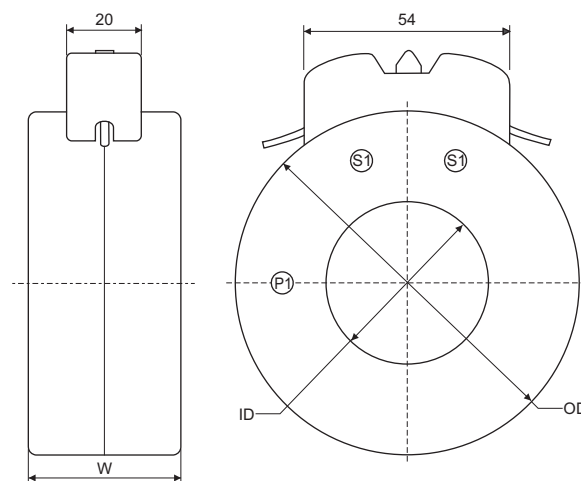

Type TW

Current Transformers - Rectangular Type

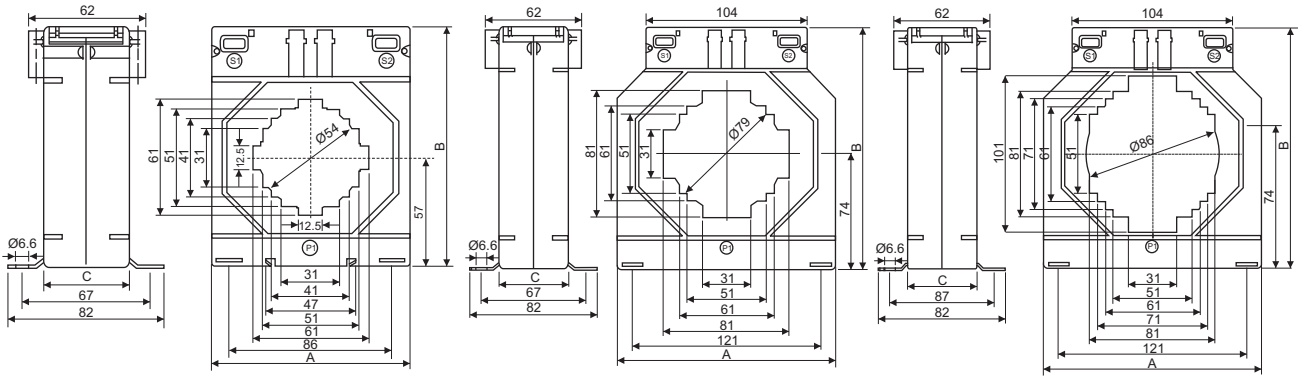

Type 104/60

Type 104/80

Type 104/100

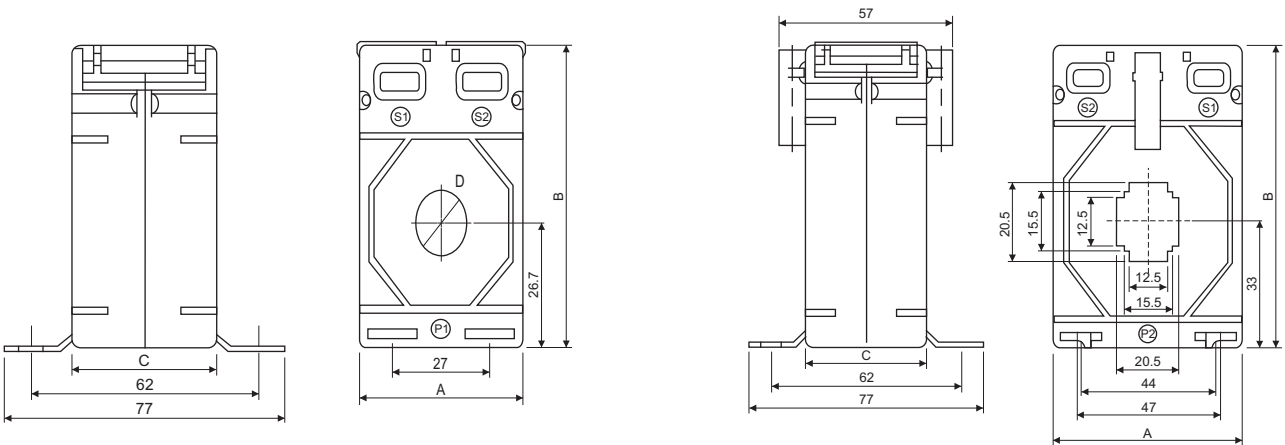

Type 45/D

Type 62/22

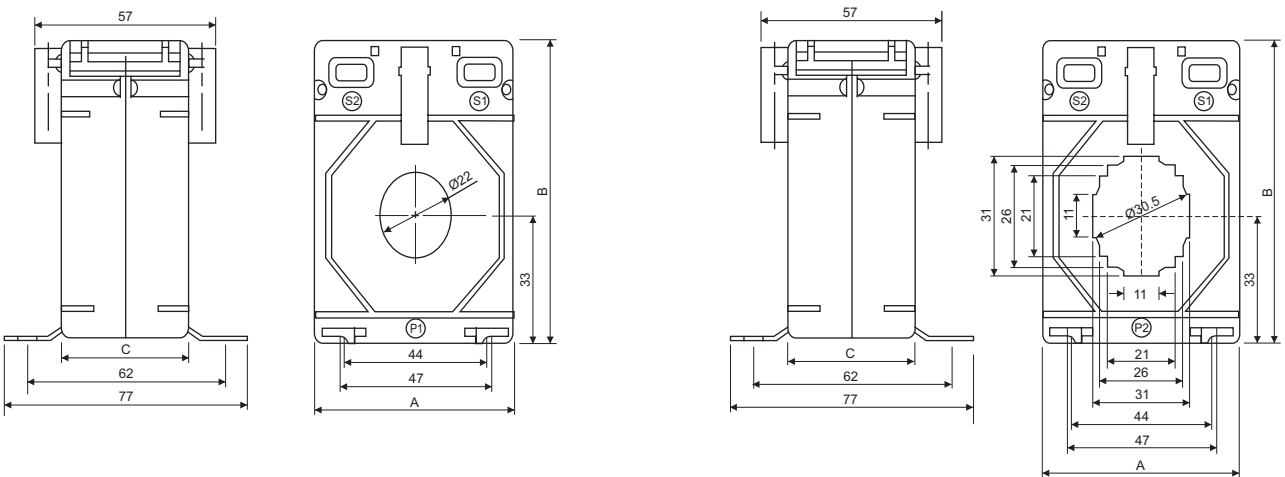

Type 62/20

Type 62/30

Current Transformers - Rectangular Type

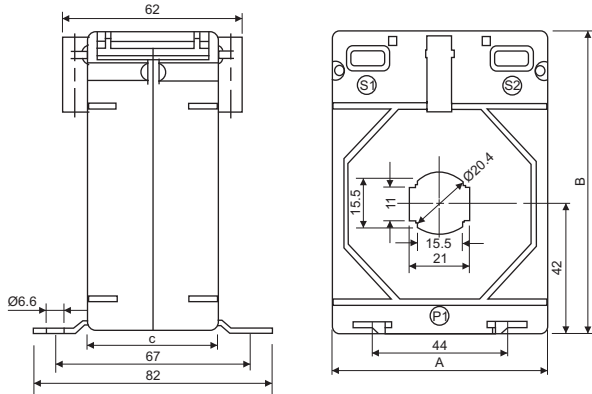

Type 74/20

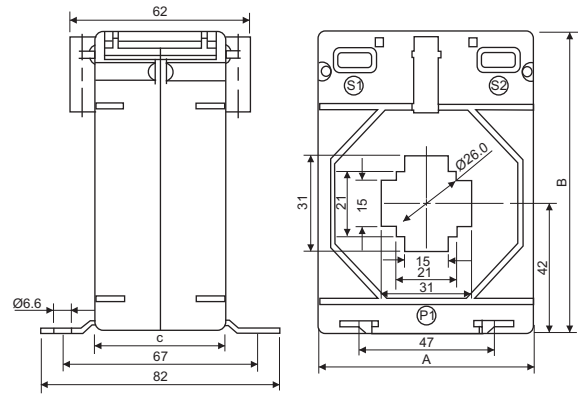

Type 74/30

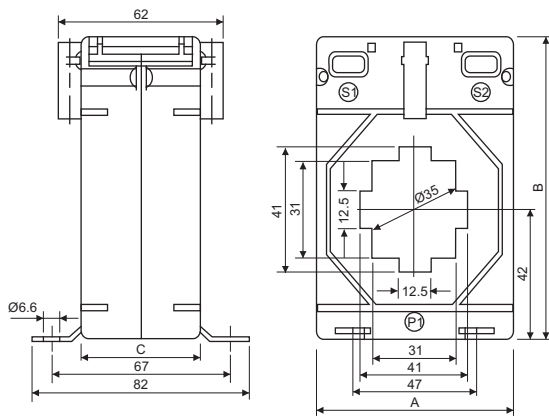

Type 74/40

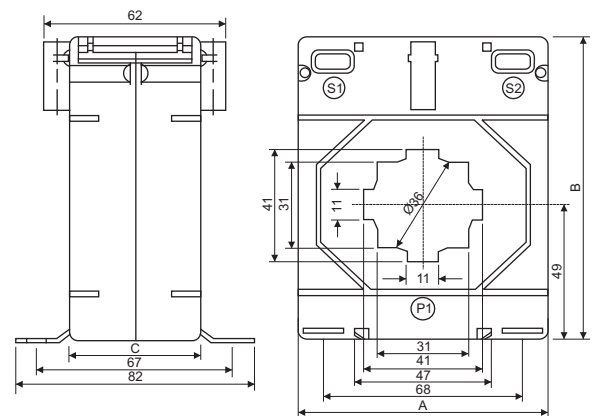

Type 86/40

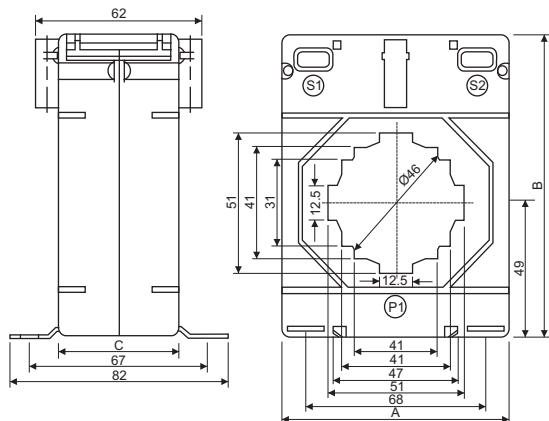

Type 86/50

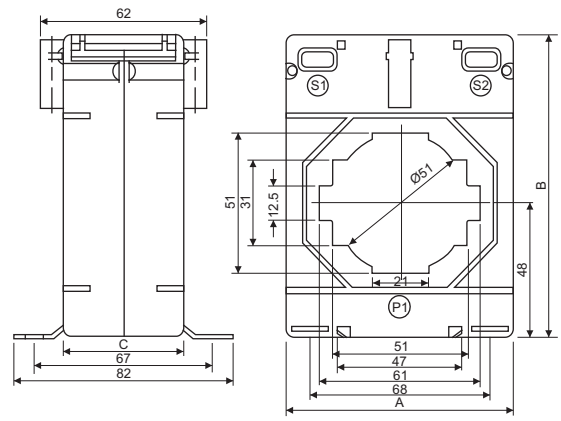

Type 86/60



Digital Panel Meters

Single Function Digital Panel Meter | VEGA

- Wide operating range of auxiliary supply
- Field programmable CT/PT ratio with password protection
- Auto scaling of Kilo and Mega
- Displays average and phase quantities*
- Ergonomic design
- Ease of installation and usage
- Standard size of 96 x 96 mm
- Auto and manual scrolling*
- Phase indication of displayed parameter through LED*
- Ammeter with secondary currents of 1 A and 5 A

* Applicable to 3 Phase Meters



VAF Digital Panel Meters | VEGA

- 3 line LED display
- Measures V, A, f and RPM
- Models with secondary current of 5 A and 1 A
- Password protected programming mode through keypad includes
 - RPM : Number of poles programmable from 2 to 16
 - CT/PT ratio
- Suitable for 50/60 Hz electrical systems
- Auto scaling of Kilo & Mega LEDs
- Rugged design for industrial use
- Compact size of 96 x 96 mm





Multifunction Digital Panel Meters | VEGA

- 3 Line LED display
- Parameters measured - V, A, f, pf, neutral Current, phase angle, power, energy, MD kVA, MD kW, average load
- Models with secondary currents of 5 A and 1 A
- Unidirectional / bidirectional recording
- Cumulative import & export and recording of reset parameters
- Current reversal indications
- Total Harmonic Distortion (THD) display
- Programmability and communication through RS485 port
- Easy programmability through key pad
- Field programmable CT & PT ratios with password protection
- Two relays provided for tripping fault circuits on preprogrammed abnormal system conditions (Optional)
- Available in three ranges - Model A, B, C
- Auto scaling of Kilo, Mega & Giga LEDs
- Standard size of 96 x 96 mm
- Rugged design for industrial use



Technical Specifications:

(Common for Single Function, VAF & Multi-Function Panel meters)

Model	VEGA	
Auxiliary Supply	Auxiliary voltage	Single function : 90 to 300 V AC VAF : 90 to 300 V AC Multifunction : 80 to 300 V AC
	Auxiliary burden	< 4 VA
	Frequency range	50 Hz \pm 5%
Measuring Circuit (Parameters as applicable to individual meters)	Class of accuracy	For voltage, current and energy : Class 1.0 For frequency : 0.2% of mid frequency (Parameters as applicable to individual meters)
	Measurement circuit burden	< 0.2 VA per phase
	Input voltage measurement range	10 V to 300 V (P-N) 17.32 V (P-P) to 520 V (P-P)
	Basic current	-/5 A, -/1 A
	Input current measurement range	2% to 120% of basic current
	Voltage range for class of accuracy	57.7 V (P-N) to 277 V (P-N) 100 V (P-P) to 480 V (P-P)
	Current range for class of accuracy	5% to 120% of basic current
	Input frequency range	45 Hz to 65 Hz
Insulation Properties	Impulse voltage test	\pm 4 kV as per IEC 62053-21
	AC voltage test	4 kV double insulation as per IEC62053-21
	Insulation resistance	500 V DC as per IS 13779
Electrical Requirements	Test of power consumption	as per IEC 62053-21
	Voltage dips and interrupts	as per IEC 61326-1
	Short time over current protection	For Multifunction, VAF and Ammeter : 20 times of I_{max} for half a second as per 7.2 of IEC 62053-21 (Not applicable for Voltmeter and Frequency meter)
Electro-Magnetic Compatibility (EMC)	Fast transients burst test	\pm 4 kV as per IEC 61000-4-4
	Immunity to electrostatic discharge	\pm 8 kV air discharge, \pm 6 kV contact discharge as per IEC 61000-4-2
	Radiated, radio-frequency, electromagnetic field immunity test	10 V/m as per 61000-4-3
	Immunity to electromagnetic HF fields through conducted lines	3 V as per IEC 61000-4-6
	Surge immunity test	\pm 4 kV as per IEC 61000-4-5
	Rated power frequency magnetic fields	1 A/m as per IEC 61000-4-8
	Emission	Class B as per CISPR 22
Operating Conditions	Operating temperature	0°C to +55°C
	Storage temperature	-20°C to +70°C
	Humidity	0 to 95% relative humidity non-condensing
Mechanical Tests	Shock	40 g in 3 planes
	Vibration	10 to 55 Hz, 0.15 mm amplitude
	Casing	Plastic mould protected to IP51 from front side
Dimensions	Weight	Single function : 255 g (approx.) VAF : 350 g (approx.) Multifunction : 400 g (approx.)
	Dimensions	Single Function : 96* 96* 45 mm (approx.) VAF : 96* 96* 45 mm (approx.) Multifunction : 96* 96* 65 mm (approx.)
Certifications	 	

Display Parameters

Single function digital panel meter

Display parameter list		1Phase Voltmeter	3 phase Voltmeter	1Phase Ammeter	3Phase Ammeter	Frequency Meter
Voltage	R Phase	✓	✓			
	Y Phase		✓			
	B Phase		✓			
	Line Voltage		✓			
	Average		✓			
Current	R Phase			✓	✓	
	Y Phase				✓	
	B Phase				✓	
	Average				✓	
Frequency						✓

VAF digital panel meter

Display parameter list		VAF meter
Voltage	R Phase	✓
	Y Phase	✓
	B Phase	✓
	Line Voltage	✓
	Average	✓
Current	R Phase	✓
	Y Phase	✓
	B Phase	✓
	Average	✓
Frequency		✓
RPM (Rotations Per Minute)		✓

Multifunction digital panel meter

	Parameters	Model A	Model B	Model C
Instantaneous Parameters	V1 V2 V3 V_{avg} V12 V23 V31	✓	✓	✓
	A1 A2 A3 A_{avg}	✓	✓	✓
	A_n		✓	✓
	F	✓	✓	✓
	% Load		✓	✓
	% A Unbal, % V Unbal	✓	✓	✓
	PF-t PF-1 PF-2 PF-3	✓	✓	✓
	RPM (Rotations per minute)	✓	✓	✓
	Phase Angle $A^{\circ}1 A^{\circ}2 A^{\circ}3$	✓	✓	✓
	W1 W2 W3 W_{sum}	✓	✓	✓
	VA1 VA2 VA3 VA_{sum}	✓	✓	✓
	VAR1 VAR2 VAR3 VAR_{sum}	✓	✓	✓
Demand/ Load Parameters	Maximum demand MD VA, MD W, Max Avg A		✓	✓
	Rising demand RD VA (Import & Export), RD W, Avg A		✓	✓
	Time remaining (Import & Export) for VA		✓	✓
	Hr MD/Max occurred (VA, W, A)		✓	✓
Cumulative Parameters	Import Wh	✓	✓	✓
	Import Vah	✓	✓	✓
	Import Varh (Lead & Lag)	✓	✓	✓
	Import run hours	✓	✓	✓
	Export Wh			✓
	Export Vah			✓
	Export Varh (Lead & Lag)			✓
	Export run hours			✓
	ON hours	✓	✓	✓
	INTR	✓	✓	✓
	No. of Resets	✓	✓	✓
Reset MD	Reset MD VA		✓	✓
	Reset MD W		✓	✓
	Reset Max Avg A		✓	✓
Reset Cumulative Parameters	Import Wh	✓	✓	✓
	Import Vah	✓	✓	✓
	Import Varh (Lead & Lag)	✓	✓	✓
	Import run hours	✓	✓	✓
	Export Wh			✓
	Export Vah			✓
	Export Varh (Lead & Lag)			✓
	Export run hours			✓
Harmonic	V V1 V2 V3 - harmonic			✓
	A A1 A2 A3 - harmonic			✓
Modbus	Modbus slave ID	✓	✓	✓
	Baud rate value	✓	✓	✓
Relays (Optional)	2 Relays for fault tripping	✓	✓	✓

Overall Dimensions (mm)

(Common for Single Function, VAF & Multi-Function Panel meters)

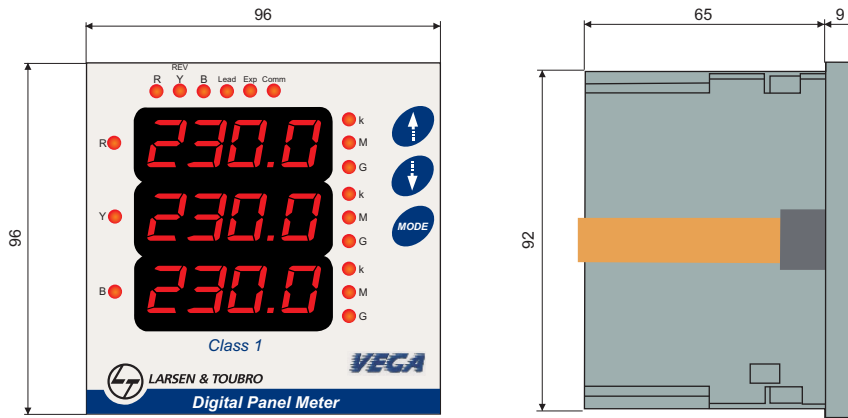

Panel Cutout Dimensions 92 mm x 92 mm

All Dimensions are in mm

Connection Details

Single Function Meters

Single Phase Voltmeter	Three Phase Voltmeter
Single Phase Ammeter	Three Phase Ammeter
Frequency Meter	

VAF Meters

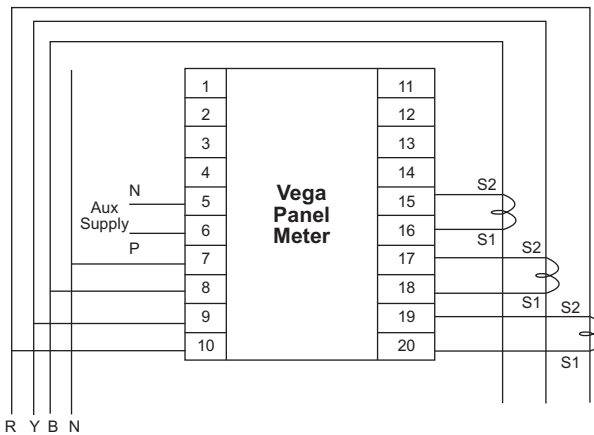

Multifunction Meters

3 Phase 4 Wire

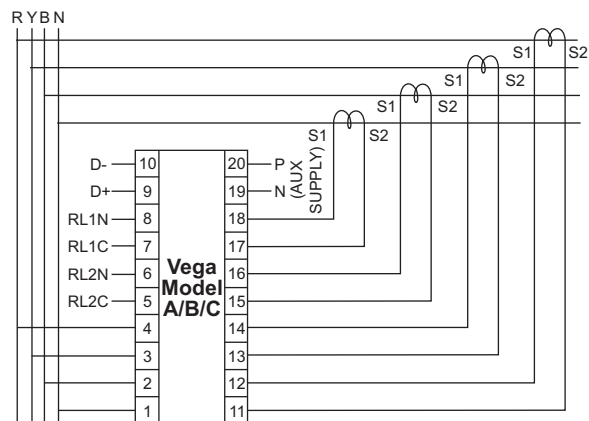

3 Phase 3 Wire

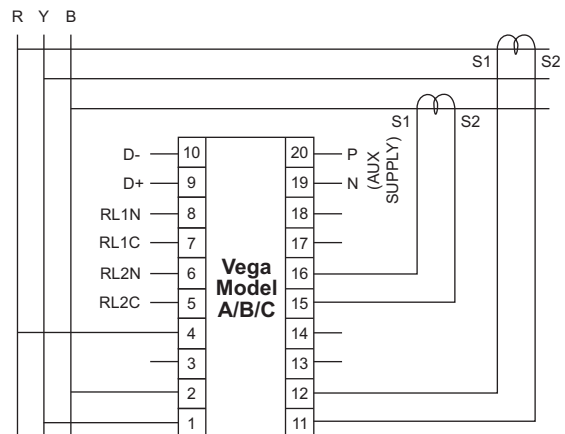

NOTE:

- Connection of point 17 and 18 is not applicable for model A
- D- and D+ are for communication using RS485
- RL1 and RL2 are relay connections

RS485 connection diagram

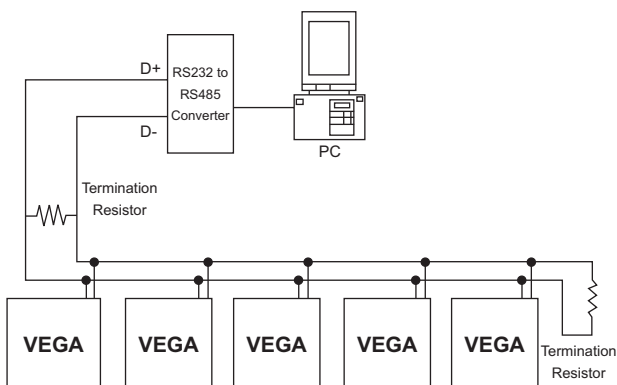

Ordering Information

Single Function Meters

Type of Meter	1 Phase / 3 Phase	Cat. No.
Voltmeter	1 Phase Meters	WDS101FCV00
	3 Phase Meters	WDS301FCV00
Ammeter (5 A secondary)	1 Phase Meters	WDS101FCA00
	3 Phase Meters	WDS301FCA00
Ammeter (1 A secondary)	1 Phase Meters	WDS101OCA00
	3 Phase Meters	WDS301OCA00
Frequency Meter		WDS121FCF00

VAF Meters

Type	Current Rating	Cat. No.
VAF Meters 90-300 V Aux. Supply	5 A	WDV303FC000
	1 A	WDV303OC000

Multifunction Meters

Accuracy	Type of Meter	Current Rating	Relay	Cat. No.
Class 1	Model A	5 A	With Relay	WDM303FDWA0
			Without Relay	WDM303FDWA1
		1 A	With Relay	WDM303ODWA0
			Without Relay	WDM303ODWA1
	Model B	5 A	With Relay	WDM303FDNB0
			Without Relay	WDM303FDNB1
		1 A	With Relay	WDM303ODNB0
			Without Relay	WDM303ODNB1
	Model C	5 A	With Relay	WDM303FDNC0
			Without Relay	WDM303FDNC1
		1 A	With Relay	WDM303ODNC0
			Without Relay	WDM303ODNC1
Class 0.5	Model A	site selectable	without relay	WDM313CDWA1
	Model B	site selectable	without relay	WDM313CDNB1
	Model C	site selectable	without relay	WDM313CDNC1

Intelligent Panel Meter | QUASAR

The meter is designed with DSP technology to combine measurement of both instantaneous and cumulative values in an electrical feeder. The parameters are displayed over 22 screens that can be scrolled up & down by front panel push buttons.

- Class 0.5 & 1.0 as per IS & IEC standards
- kWh, kVAh & kVAh
- LCD with back light
- CT/PT ratio programming
- RS485 communication
- Phase sequence
- Harmonic measurement



Technical Specifications:

Model	QUASAR	
Accuracy	For power	Class 1.0
	IEC 62052-11, 62053-21/ IS 13779	
	For voltage	±10%
	For current	0.5% of readout ± 2 digits
Voltage (Vn)	3 Ph 4 W- 415 V AC (-40% to +20%)	
	3 Ph 4 W- 110 V AC (-40% to +20%)	
	3 Ph 3 W- 110 V AC (-40% to +20%)	
Current (In)	5 A or 1 A ($I_{max} = 2I_n$)	
Starting Current	0.2% in (Class 1.0)	
Frequency	50 Hz ±5%	
Load Characteristics	< 8 VA in potential circuit	
	< 0.5 VA in current circuit	
Electromagnetic Compatibility:		
Electrical Fast Transient	As Per IEC 62052-11, 62053-21, Test Level: 4 kV, 5k Hz	
Surge Immunity	As Per IEC 62052-11, 62053-21, Test Level: 4 kV	
Influence of Short Time Over Currents	20 times I_{max} for 0.5 sec at rated frequency. As per IEC 62053-21	
Case Material	Plastic moulded protected to IP51- IEC 62052-11, 62053-21/IS 13779 (Class 1.0) (with panel)	
Insulation Properties:		
Insulation Resistance	As per IEC 62052-11, 62053-21 / IS 13779 (Class 1.0)	
AC voltage Test	2 kV AC RMS, 50 Hz for 1 minute as per IEC 62052-11	
Impulse Voltage	6 kV, 1.2/50 μ sec, as per IEC 62052-11	
Voltage Dips and Interrupts	As per IEC 61000-4-11	
Display	Backlit LCD, 10 mm height digits	
Pulse Output	Pulses/kWh	Voltage/Current
	2,500 / (external CT* PT)	3 Ph 4 W 415 V (L-L) / 5 A
	12,500 / (external CT* PT)	3 Ph 4 W 415 V (L-L) / 1 A
	10,000 / (external CT* PT)	3 Ph 4 W / 3 W 110 V (L-L) / 5 A
	50,000 / (external CT* PT)	3 Ph 4 W / 3 W 110 V (L-L) / 1 A
Temperature	-10°C to 60°C for operation	
	-20°C to 70°C for storage	
Humidity	95% RH non condensing	
Dimension	96 x 96 mm - depth 105 mm	
Weight	< 600 gms	

Technical Specifications:

Model	QUASAR	
Pulse output	Pulses/kWh	Voltage/Current
	2,500 / (external CT* PT)	3 Ph 4 W 415 V (L-L) / 5 A
	12,500 / (external CT* PT)	3 Ph 4 W 415 V (L-L) / 1 A
	10,000 / (external CT* PT)	3 Ph 4 W / 3 W 110 V (L-L) / 5 A
Temperature	-10°C to 60°C for operation	
	-20°C to 70°C for storage	
Humidity	95% RH non condensing	
Dimension	96 x 96 mm - depth 105 mm	
Weight	< 600 gms	

Display Parameters:

- Screen 1 - V, A, kW
- Screen 2 - R - Y - B Voltages
- Screen 3 - R - Y - B Currents
- Screen 4 - R - Y - B kW
- Screen 5 - R - Y - B kVA
- Screen 6 - R - Y - B kVA
- Screen 7 - R - Y - B pF
- Screen 8 - R - Y - B Volt angles
- Screen 9 - R - Y - B Phase angles
- Screen 10 - kW + kVA + kVA
- Screen 11 - Pd + pF + F
- Screen 12 - kWh
- Screen 13 - kVAh (L)
- Screen 14 - kVAh (C)
- Screen 15 - kVAh
- Screen 16 - R ph Voltage - Harmonics
- Screen 17 - Y ph Voltage - Harmonics
- Screen 18 - B ph Voltage - Harmonics
- Screen 19 - R ph Current - Harmonics
- Screen 20 - Y ph Current - Harmonics
- Screen 21 - B ph Current - Harmonics

Overall Dimensions (mm)

Panel Cutout 92 x 92 mm

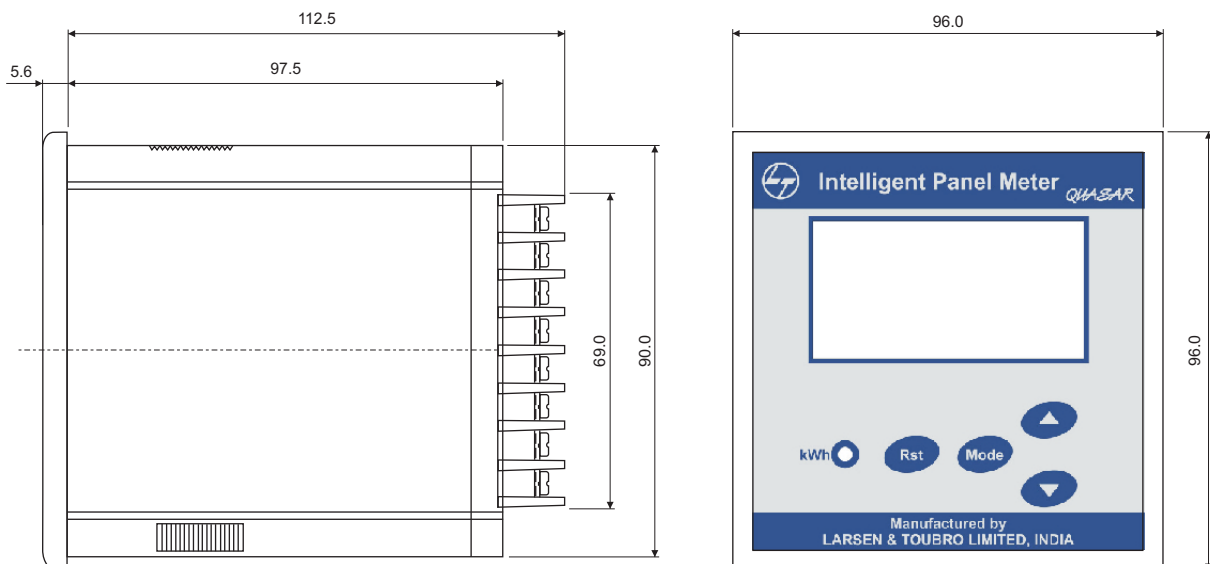

Connection Details (Wiring Diagram)

3 Ph. 4 Wire with CT & PT

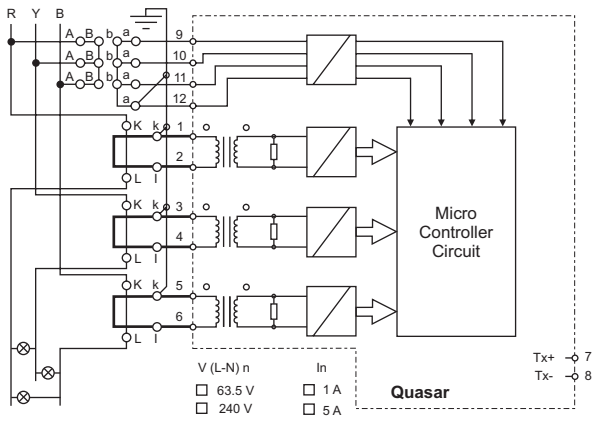

3 Ph. 4 Wire with CT & without PT

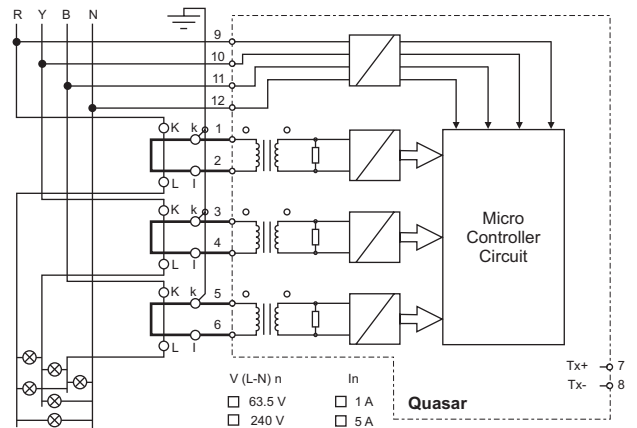

3 Ph. 3 Wire with CT & PT

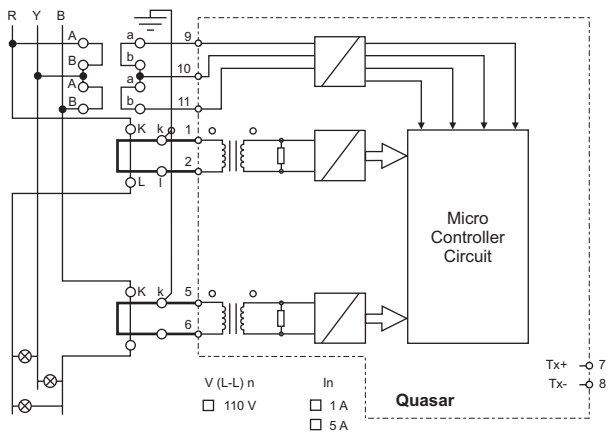

3 Ph.3 Wire with CT & without PT

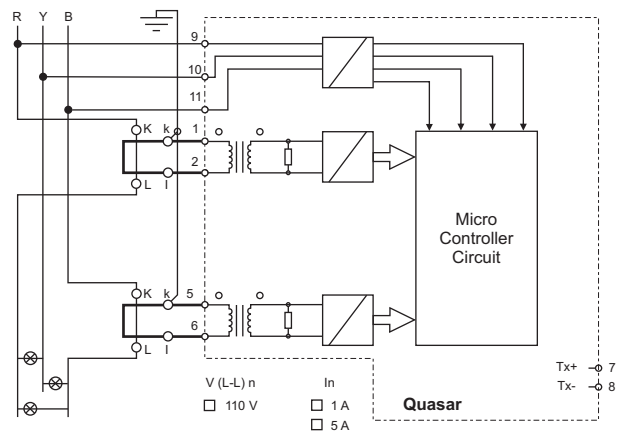

Ordering Information

Accuracy	Type	Voltage	Secondary Current	RS485	Cat. No.
Class 1	3 Ph, 4 W	240 V (L-N)	1 A		WI300FC1300
				✓	WI300FC13RS
			5 A		WI300FC5300
				✓	WI300FC53RS
	3 Ph, 3 W	110 V (L-L)	1 A		WI301FC1300
				✓	WI301FC13RS
			5 A		WI301FC5300
				✓	WI301FC53RS
	3 Ph, 4 W	110 V (L-L)	1 A		WI300FB1300
				✓	WI300FB13RS
			5 A		WI300FB5300
				✓	WI300FB53RS
Class 0.5	3 Ph, 4 W	240 V (L-N)	1 A		WI300FC1200
				✓	WI300FC12RS
			5 A		WI300FC5200
				✓	WI300FC52RS
	3 Ph, 3 W	110 V (L-L)	1 A		WI301FC1200
				✓	WI301FC12RS
			5 A		WI301FC5200
				✓	WI301FC52RS
	3 Ph, 4 W	110 V (L-L)	1 A		WI300FB1200
				✓	WI300FB12RS
			5 A		WI300FB5200
				✓	WI300FB52RS

Three Phase Multifunction Meter | NOVA

Nova is a compact, digital, panel mount meter for kWh measurement. Nova is flush mount 3 Phase 4 Wire CT operated kWh meter with (optional) RS485 MODBUS communication.

- Accuracy class - 1.0
- Measures kWh & kW
- Forwarded energy registration in case of current reversal
- Phase wise Voltage, Current & Power on display
- Average Voltage & Current on display
- Phase sequence on display
- RS485 MODBUS communication
- Auto & manual display mode
- User friendly menu driven LCD display
- Field programmable CT/PT ratio
- Customised LCD display & Push Button navigation
- Scroll lock feature for locking of a desired parameter on display
- Low CT/PT burden
- High resolution energy
- Auxiliary supply 88 V to 300 V AC/DC



Technical Specifications:

Model	NOVA
Enclosure	Engineering Plastic complying to IP51
Dimension	96 x 96 mm x 105 mm (HxWxD) Panel Cutout: 92 x 92 mm
Connection	3 P 4 W
Display	Backlit LCD
Type	kWh Meter
Measurements	kWh / kW / Frequency / Voltage / Current
Starting Current	0.2% of rated current (5 A)
Class of Accuracy	Class 1.0
Current	5 A (rated), 10 A (max)
Voltage (P-N)	3 x 240 V (-30 % to +20 % of V Ref)
Frequency	50 Hz \pm 5%
Auxiliary Supply	88 V to 300 V AC/DC
Weight	450 gm \pm 5%
Weight with Packaging	610 gm \pm 5%

Display Parameters:

- Cumulative EB Energy kWh
- Average Voltage
- Average Current
- Total Active Power
- Frequency
- R Phase Voltage
- Y Phase Voltage
- B Phase Voltage
- R Phase Current
- Y Phase Current
- B Phase Current
- R Phase Active Power
- Y Phase Active Power
- B Phase Active Power
- Phase Sequence

Overall Dimensions (mm)

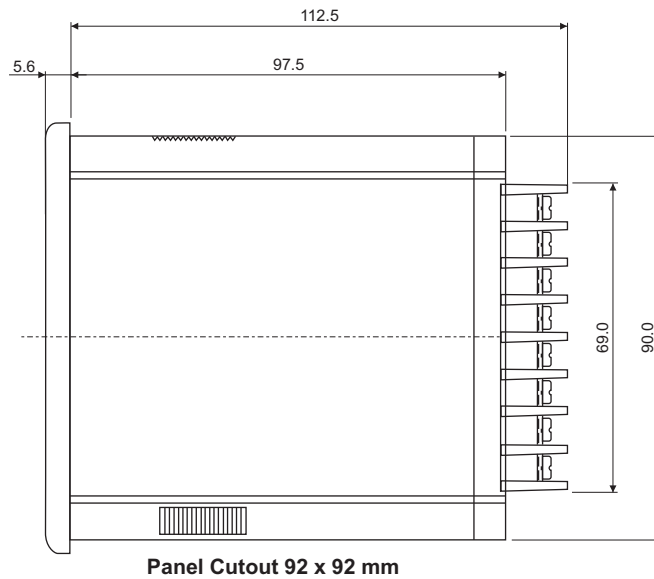

Connection Details

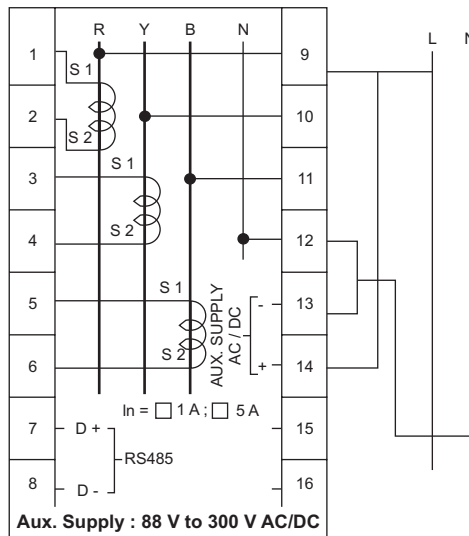

- Meter connection should be done exactly as shown in above diagrams
- Make the CT connections on terminals 1-2 (R-Ph), 3-4 (Y-Ph) and 5-6 (B-Ph)
- Make the PT connections on the terminals 9 (R), 10 (Y), 11 (B) and 12 (N)
- Connect the Auxiliary Supply (88 V to 300 V AC/DC) to the terminals 13 (-ve) and 14 (+ve) to power ON the meter. It can be done by shorting one phase with auxiliary as shown in the above picture

Ordering Information

Cat. No.	Description
WM30KFC3CRS	3 Ph 4 W 240 V 5 A MFM with RS485 port - Nova
WM30KFC3C00	3 Ph 4 W 240 V 5 A MFM - Nova

Counter Type kWh Meter | ACRUX

This is an ideal product for control panels to measure kWh energy. Compactness of the meter ensures that it will fit in smartly into any panel. L&T offers this product in 3 phase 4 wire.

- Class 1.0 accuracy
- Active energy measurement
- Stepper motor counter display
- Pulse output LED
- Terminal covers with sealing provision

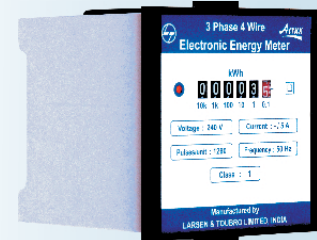

Technical Specifications:

Model	ACRUX
Accuracy	Class 1.0 as per IS 13779
Voltage Rating	240 V (3 Phase 4 Wire)
Current Rating (Ib)	5 A & 1 A
Frequency	50 Hz \pm 5%
Maximum Current	200% of Ib
Starting Current	0.4% of Ib
Operating Temperature	0 to 55°C
Display	6 Digit stepper motor counter
Enclosure	Polycarbonate
Weight	500 g (approximate)
Mounting	Flush mounting

Display Parameters:

Cumulative Energy kWh

Overall Dimensions (mm)

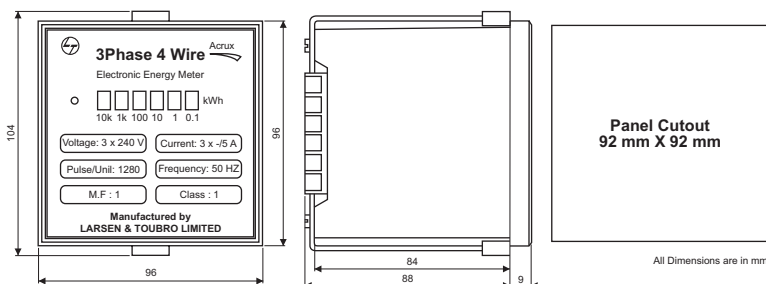

Connection Details

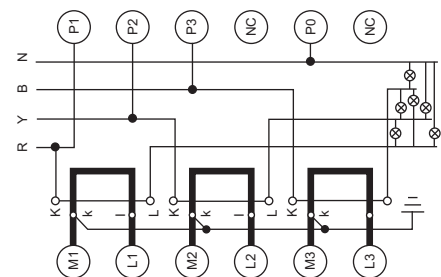

3 P 4 W with CT 240 V-1 A & 5 A

Ordering Information

Cat. No.	Description
WM301FC1C10	3 Ph 4 W 240 V 1 A (kWh meter counter type) - Acrux
WM301FC3C10	3 Ph 4 W 240 V 5 A (kWh meter counter type) - Acrux

Dual Source Meter | GEMiNi

An innovative panel meter designed for dual source energy measurement. It serves as a replacement for two separate energy meters necessary for metering same application with dual energy sources.

- Class 1.0 accuracy as per IS & IEC standards
- Dual energy register for dual energy source
- RS485 MODBUS communication
- Field programmable CT, PT Values & Meter ID



Technical Specifications:

Model	GEMiNi
Enclosure	Engineering Plastic complying to IP51
Dimension	96 x 96 mm x 105 mm (HxWxD) Panel Cutout: 92 x 92 mm
Connection	3 P 4 W
Display	Backlit LCD
Type	kWh Meter
Measurements	kWh / kW / Frequency / Voltage / Current
Starting Current	0.2% of rated current (5 A)
Class of Accuracy	Class 1.0
Current	5 A (rated), 10 A (max)
Voltage (P-N)	3 x 240 V (-30 % to +20 % of V Ref)
Frequency	50 Hz ± 5%
Auxiliary Supply	88 V to 300 V AC/DC
DG Sensing Input	18 V-60 V DC/80 V-300 V AC
Weight	470 gm ± 5%
Weight with Packaging	630 gm ± 5%

Dual Energy Registers:

Two separate energy registers are provided, one for EB (Electricity Board supply) and another for G (Generator Supply). Normally meter accumulates energy in EB register. Whenever the DG sensing signal (18 to 60 V DC /80 to 300 V AC) is present, meter accumulates energy in G register. Separate LED indication is provided on the meter front Panel, which glows when DG sensing signal is present.

Display Parameters:

- Cumulative EB Energy kWh
- Cumulative Gen. Energy kWh
- Average Voltage
- Average Current
- Total Active Power
- Frequency
- R Phase Voltage
- Y Phase Voltage
- B Phase Voltage
- R Phase Current
- Y Phase Current
- B Phase Current
- R Phase Active Power
- Y Phase Active Power
- B Phase Active Power
- Phase Sequence

Overall Dimensions (mm)

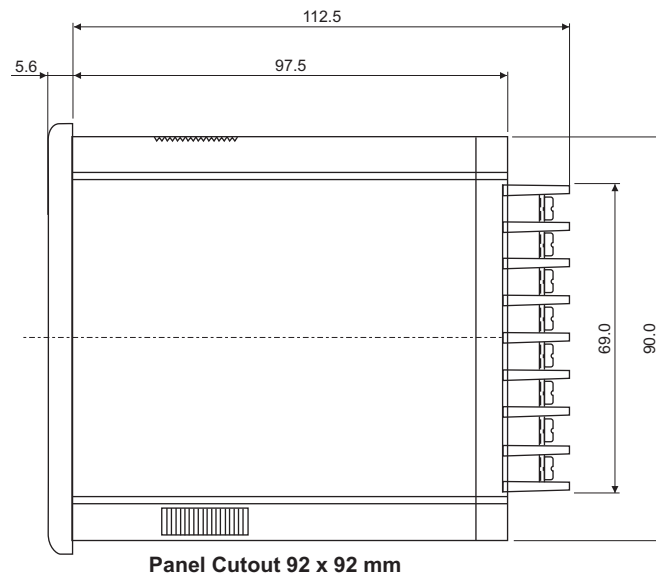

Connection Details

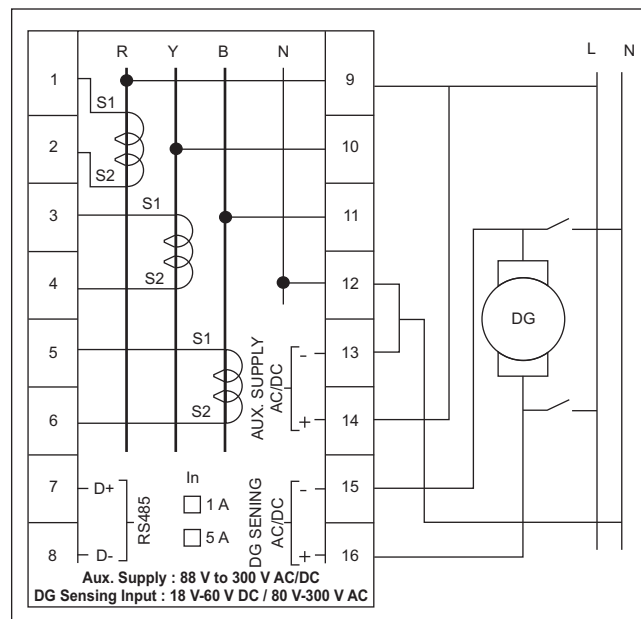

- Meter connection should be done exactly as shown in above diagram
- Make the CT connections on terminals 1-2 (R-Ph), 3-4 (Y-Ph) and 5-6 (B-Ph)
- Make the PT connections on the terminals 9 (R), 10 (Y), 11 (B) and 12 (N)
- Connect the Auxiliary Supply (88 V to 300 V AC/DC) to the terminals 13 (-ve) and 14 (+ve) to power on the meter; It can be done by shorting one phase with auxiliary as shown in the above picture
- Connect the DG sensing input (18 V - 60 V DC/80 V - 300 V AC) on terminal 15 (-ve) & 16 (+ve)

Ordering Information

Cat. No.	Description
WM30DFC3CRS	3 Ph 4 W 240 V 5 A with RS485 (Dual source kWh meter) - GEMiNi

mi-ENERGY

mi-ENERGY is L&T's DIN rail mounted meter. Available in 3 phase and 1 phase models, these meters can be mounted inside distribution boxes to monitor electric consumption of identified loads, circuits and areas.

- LCD display
- Class 2 accuracy
- Displays day, week, month and push-to-push kWh consumption
- Push Button for parameter scrolling
- Low starting current
- Reverse current indication*
- Compact size and easy mounting

* For 3 Phase Meter



Display Parameters

Parameters		3-Phase Meter	1-Phase Meter
Instantaneous Parameters	Phase voltage	✓	✓
	Phase current	✓	✓
	Power factor	✓	
	Active power	✓	✓
	Reactive power	✓	
	Apparent power	✓	
	Frequency	✓	
Maximum Demand	Present month	✓	
	Previous month	✓	
kWh Consumption	Total	✓	✓
	Present day	✓	✓
	Present week	✓	✓
	Present month	✓	✓
	Push-to-push	✓	✓
	Previous day	✓	✓
	Previous week	✓	✓
	Previous month	✓	✓

Technical Specifications:

Display	Type	6 digit LCD
	Height	6 mm (10 mm in case of 3 Phase meter)
Measuring Circuit	Class of accuracy	Class 2 as per IEC 62053-21
	Measurement circuit burden	<1 W, <8 VA
	Rated Voltage	240 V
	Current	3 phase: 10-60 A 1 phase: 5-30 A
	Starting current	3 phase: 40 mA 1 phase: 20 mA
	Voltage range for class of accuracy	-30% to +20% of rated voltage
	Current range for class of accuracy	5% I_b to I_{max}
	Input frequency range	50 Hz \pm 5%
Insulation Properties	Impulse voltage test	\pm 6 kV as per IEC 62052-11
	AC voltage test	4 kV double insulation as per IEC 62053-21
	Insulation resistance	500 V DC as per IS 13779
Electrical Requirements	Test of power consumption	IEC 62053-21
	Voltage dips and interrupts	IEC 62052-11
	Short timeover current protection	20 times of I_{max} for half a second as per IEC 62053-21
Electro-Magnetic Compatibility (EMC)	Fast transients burst test	IEC 61000-4-4
	Immunity to electrostatic discharge	IEC61000-4-2
	Immunity to electromagnetic HF fields	IEC61000-4-3
	Immunity to conducted disturbances by RF field	IEC61000-4-6
	Surge immunity test	\pm 4 kV as per IEC 61000-4-5
Climatic Test	Dry heat test	IS 9000 (part 3)
	Cold test	IS 9000 (part 2)
	Damp heat cyclic test	IS 9000 (part 5)
Operating Conditions	Operating temperature	-10°C to +55°C
	Storage temperature	-20°C to +70°C
Mechanical Tests	Shock	IS 9000 (part 7)
	Vibration	IS 9000 (part 8)
	Resistance to dust and water	IP20
Dimensions	Weight	3 phase: 460 g (approx.) 1 phase: 150 g (approx.)
	Dimensions	3 phase: 125 mm x 83 mm x 63.5 mm (approx.) 1 Phase: 36 mm x 83 mm x 66.73 mm (approx.)

Wiring Diagram

3-Phase

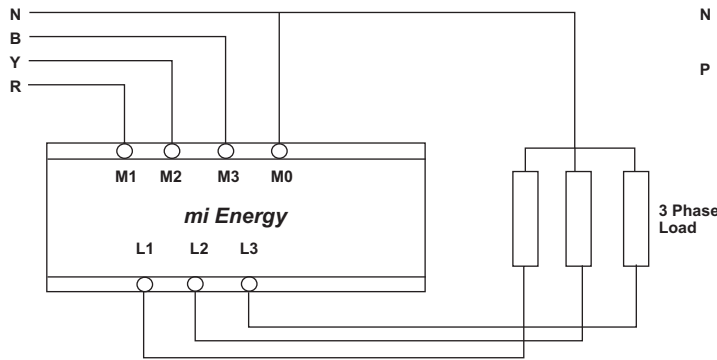

1-Phase

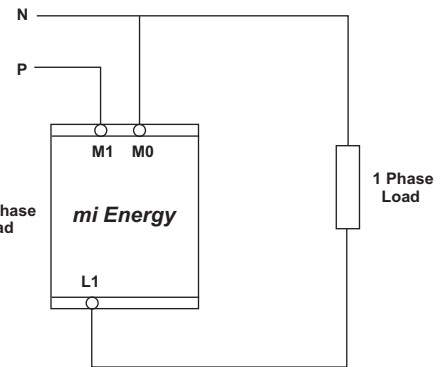

Dimensional Details

3-Phase



1-Phase

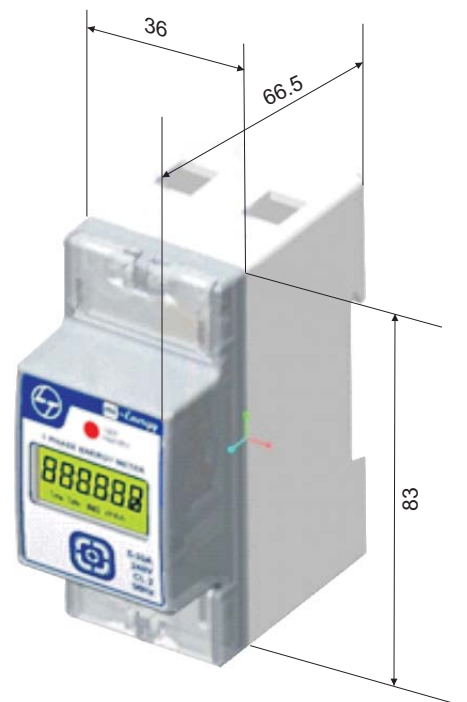

All Dimensions in mm

Ordering Information

3 phase 4 wire 240 V 10-60 A	W4DLD100600
1 phase 2 wire 240 V 5-30 A	W2DLD050600

Get the Switchgear Training Edge!

Aimed at maximizing productivity, conserving energy, minimizing costs and enhancing safety, our Electrical & Automation training programmes have benefitted 1.12 Lakh professionals in the last over 25 years. These training programmes are highly beneficial as they provide right exposure and impart knowledge on selection, installation, maintenance and testing of Electrical & Automation products.

So gain the advantage and go the extra mile with:

- 14 courses on contemporary topics
- Courses applicable to all switchgear brands
- Training Centers in Pune, Lucknow, Coonoor & Vadodara
- Blend of theory and practical experience

The typical training programmes cover:

- Low Voltage & Medium Voltage Switchgear
- Switchboard Electrical Design
- AC Drives & Building Management Solutions
- Protective Relays, Earthing & Harmonics
- Energy Conservation & Management

Please contact any of the training centres for participation and detailed training programme schedule.



Pune

Larsen & Toubro Limited
Switchgear Training Centre
T-156/157, MIDC, Bhosari,
Pune: 411 026.
Tel.: (020) 2712 0037 / 2712 0653
Fax.: (020) 2712 2933
E-mail : STC-PUNE@LNTEBG.COM



Lucknow

Larsen & Toubro Limited
Switchgear Training Centre
C-6&7, UPSIDC, P.O. Sarojini Nagar,
Lucknow: 226 008.
Tel.: (0522) 247 6110 / 099355 63239
Fax.: (0522) 247 6015
E-mail : STC-LUCKNOW@LNTEBG.COM



Coonoor

Larsen & Toubro Limited
Switchgear Training Centre Ooty-Coonoor
Main Road, Yellanahalli
P.O., The Nilgiris – 643 243.
Tel.: (0423) 251 7107
Fax.: (0423) 251 7158
E-mail : STC-COONOOR@LNTEBG.COM



Vadodara

Larsen & Toubro Limited
Switchgear Training Centre
Behind L&T Knowledge City,
Near Village Ankhola,
Vadodara - 390 019.
Tel: +91 265 245 7805
E-mail : STC-VADODARA@LNTEBG.COM



Electrical Standard Products (ESP) Branch Offices:

REGISTERED OFFICE AND HEAD OFFICE

L&T House, Ballard Estate
P. O. Box 278
Mumbai 400 001
Tel: 022-67525656
Fax: 022-67525858
Website: www.Larsentoubro.com

ELECTRICAL STANDARD PRODUCTS (ESP)

501, Sakar Complex I
Opp. Gandhigram Rly. Station
Ashram Road
Ahmedabad 380 009
Tel: 079-66304006-11
Fax: 079-66304025
e-mail: esp-ahm@LNTEBG.com

38, Cubbon Road, P. O. Box 5098
Bangalore 560 001
Tel: 080-25020100 / 25020324
Fax: 080-25580525
e-mail: esp-blr@LNTEBG.com

131/1, Zone II
Maharana Pratap Nagar
Bhopal 462 011
Tel: 0755-3080511 / 05 / 08 / 13 / 17 / 19
Fax: 0755-3080502
e-mail: esp-bho@LNTEBG.com

Plot No. 559, Annapurna Complex
Lewis Road
Bhubaneswar 751 014
Tel: 0674-6451342, 2436690, 2436696
Fax: 0674-2537309
e-mail: nayakd@LNTEBG.com

SCO 32, Sector 26-D
Madhya Marg, P. O. Box 14
Chandigarh 160 019
Tel: 0172-4646840, 4646853
Fax: 0172-4646802
e-mail: esp-chd@LNTEBG.com

L&T Construction Campus
TC-1 Building, II Floor
Mount-Poonamallee Road
Manapakkam
Chennai 600 089
Tel: 044-2270 6800
Fax: 044-22706940
e-mail: esp-maa1@LNTEBG.com

67, Appuswamy Road
Post Bag 7156
Opp. Nirmala College
Coimbatore 641 045
Tel: 0422-2588120 / 1 / 5
Fax: 0422-2588148
e-mail: esp-cbe@LNTEBG.com

Khairasol, Degaul Avenue
Durgapur 713 212
Tel: 2559848, 2559849, 2559844
Fax: 0343-2553614
e-mail: esp-dgp@LNTEBG.com

5, Milanpur Road, Bamuni Maidan
Guwahati 781 021
Tel: +91 8876554410 / 8876554417
Fax: 361-2551308
e-mail: hazrasudipto@LNTEBG.com

II Floor, Vasantha Chambers
5-10-173, Fateh Maidan Road
Hyderabad 500 004
Tel: 040-67015052
Fax: 040-23296468
e-mail: esp-hyd@LNTEBG.com

Monarch Building, 1st Floor
D-236 & 237, Amrapali Marg
Vaishali Nagar
Jaipur 302 021
Tel: 0141-4385914 to 18
Fax: 0141-4385925
e-mail: esp-jai@LNTEBG.com

Akashdeep Plaza, 2nd Floor
P. O. Golmuri
Jamshedpur 831 003
Jharkhand
Tel: 0657-2312205 / 3
Fax: 0657-2341250
e-mail: esp-jam@LNTEBG.com

Skybright Bldg; M. G. Road
Ravipuram Junction, Ernakulam
Kochi 682 016
Tel: 0484-4409420 / 4 / 5 / 7
Fax: 0484-4409426
e-mail: esp-cok@LNTEBG.com

3-B, Shakespeare Sarani
Kolkata 700 071
Tel: 033-44002572 / 3 / 4
Fax: 033-22821025 / 7587
e-mail: esp-ccu@LNTEBG.com

A28, Indira Nagar, Faizabad Road
Lucknow 226 016
Tel: 0522-4929905 / 04
Fax: 0522-2311671
e-mail: esp-Lko@LNTEBG.com

No: 73, Karpaga Nagar, 8th Street
K. Pudur
Madurai 625 007
Tel: 0452-2537404, 2521068
Fax: 0452-2537552
e-mail: esp-mdu@LNTEBG.com

EBG North Wing Office-Level 2
Gate 7, Powai Campus
Mumbai 400 072
Tel: 022-67052874 / 2737 / 1156
Fax: 022-67051112
e-mail: esp-bom@LNTEBG.com

12, Shivaji Nagar
North Ambajhari Road
Nagpur 440 010
Tel: 0712-2260012 / 6606421
Fax: 2260030 / 6606434
e-mail: esp-nag@LNTEBG.com

32, Shivaji Marg
P. O. Box 6223
New Delhi 110 015
Tel: 011-41419514 / 5 / 6
Fax: 011-41419600
e-mail: esp-del@LNTEBG.com

L&T House
P. O. Box 119
191/1, Dhule Patil Road
Pune 411 001
Tel: 020-66033395 / 66033279
Fax: 020-26164048 / 26164910
e-mail: esp-pnq@LNTEBG.com

Crystal Tower,
4th Floor, G. E. Road
Telibandha
Raipur - 492 006
Tel: 0771-4283214
e-mail: esp-raipur@LNTEBG.com

3rd Floor
Vishwakarma Chambers
Majura Gate, Ring Road
Surat 395 002
Tel: 0261-2473726
Fax: 0261-2477078
e-mail: esp-sur@LNTEBG.com

Radhadaya Complex
Old Padra Road
Near Charotar Society
Vadodara 390 007
Tel: 0265-6613610 / 1 / 2
Fax: 0265-2336184
e-mail: esp-bar@LNTEBG.com

48-8-16, Dwarakanagar
Visakhapatnam 530 016
Tel: 0891-6701125 to 30
Fax: 0891-6701139
e-mail: esp-viz@LNTEBG.com

Product improvement is a continuous process. For the latest information and special applications, please contact any of our offices listed here.



Larsen & Toubro Limited Electrical Standard Products
Powai Campus, Mumbai 400 072
Customer Interaction Center (CIC)
BSNL / MTNL (toll free) : 1800 233 5858
Reliance (toll free) : 1800 200 5858
Tel : 022 6774 5858, Fax : 022 6774 5859
E-mail : cic@LNTEBG.com Website : www.LNTEBG.com

Registered Office: L&T House, N. M. Marg, Ballard Estate, Mumbai 400 001, INDIA
SP50581 R1